

***120Rd-2 Cable Retention Arm
Assembly
Installation Notes***

Proprietary Notice and Liability Disclaimer

The information disclosed in this document, including all designs and related materials, is the valuable property of NEC Computers Inc. and/or its licensors. NEC Computers Inc. and/or its licensors, as appropriate, reserve all patent, copyright and other proprietary rights to this document, including all design, manufacturing, reproduction, use, and sales rights thereto, except to the extent said rights are expressly granted to others.

The NEC Computers Inc. product(s) discussed in this document are warranted in accordance with the terms of the Warranty Statement accompanying each product. However, actual performance of each product is dependent upon factors such as system configuration, customer data, and operator control. Since implementation by customers of each product may vary, the suitability of specific product configurations and applications must be determined by the customer and is not warranted by NEC Computers Inc.

To allow for design and specification improvements, the information in this document is subject to change at any time, without notice. Reproduction of this document or portions thereof without prior written approval of NEC Computers Inc. is prohibited.

Trademarks

All product, brand, or trade names used in this publication are the trademarks or registered trademarks of their respective trademark owners.

PN: 455-01643-000 January 2002

Copyright 2002
NEC Computers Inc.
15 Business Park Way
Sacramento, CA 95828
All Rights Reserved

Introduction

The triple-hinged cable retention arm attaches to the rear of the server and the system rack allowing cables to move as the server slides back and forth within the rack cabinet. The server cables are tie-wrapped to the cable retention arm.

The following sections provide procedures for installing the cable retention arm assembly to your server and your system rack. Installation of the cable retention arm differs depending on the type of system rack used. The cable retention arm components that shipped with your server are shown on the next page. Follow procedures pertaining to your system rack.

Unpacking

After unpacking the cable retention arm assembly, confirm that all parts shown below are included in the kit.

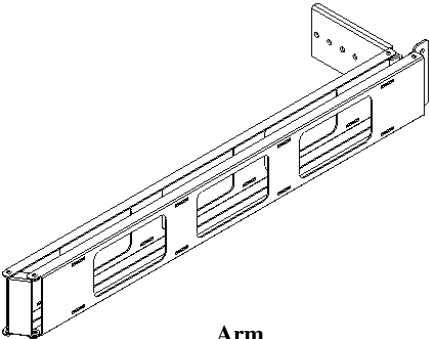

Arm

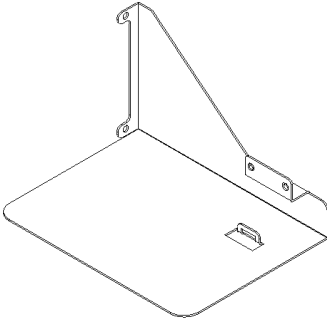

Arm Base

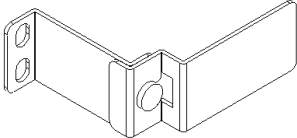

Arm Stopper Assembly

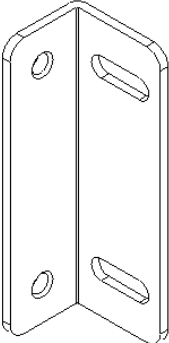

Arm Bracket ×

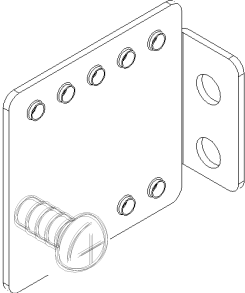

Arm Stopper A

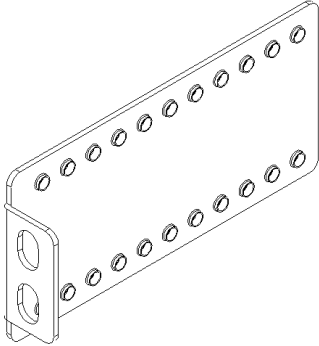

Arm Stopper B

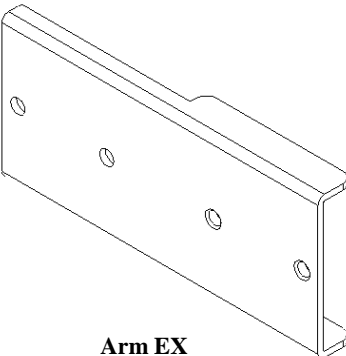

Arm EX



**Screw A
(No 6-32)**



Screw B

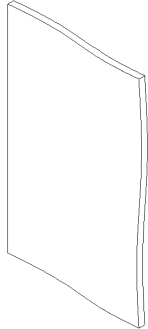

User's Guide

Preparation

The following tool is required to install the cable retention arm assembly.

Small Philips driver

Installation

This document includes three cable retention arm assembly installation procedures. They are Installation Procedure A, Installation Procedure B, and Installation Procedure C. The procedure you use for installing the cable retention arm assembly varies depending on the depth of the your system rack. Also, some of the hardware used differs depending on the procedure you use.

Use the table below to determine the correct installation procedure you should use.

Distance between the mounting surface of the front and rear vertical rails	Installation procedure you should use
700mm ~ 774mm (27.6in ~ 30.5in)	Procedure A
775mm ~ 829mm (30.5in ~ 32.6in)	Procedure B
830mm ~ 900mm (32.6in ~ 35.4in)	Procedure C

If you are unsure of the depth of your system rack, refer to the illustration below and measure the distance between the inside surface of the front and rear vertical mounting rails of your system rack.

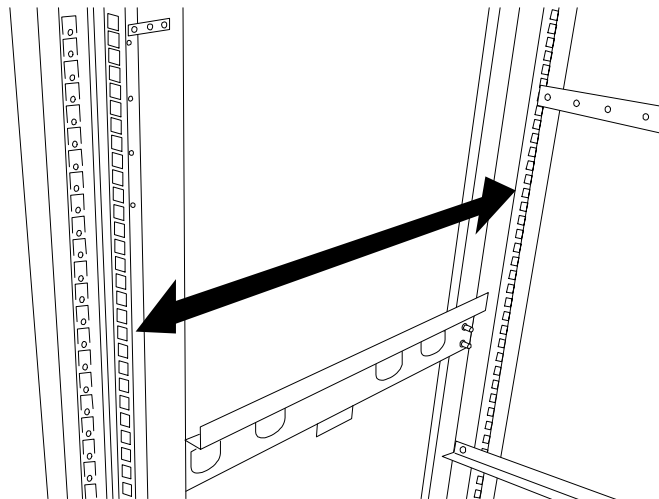

Installation Procedure A

1. Attach the Arm Base to the rear of the power supply cage using the two screws that secure the power supply cage to the chassis.

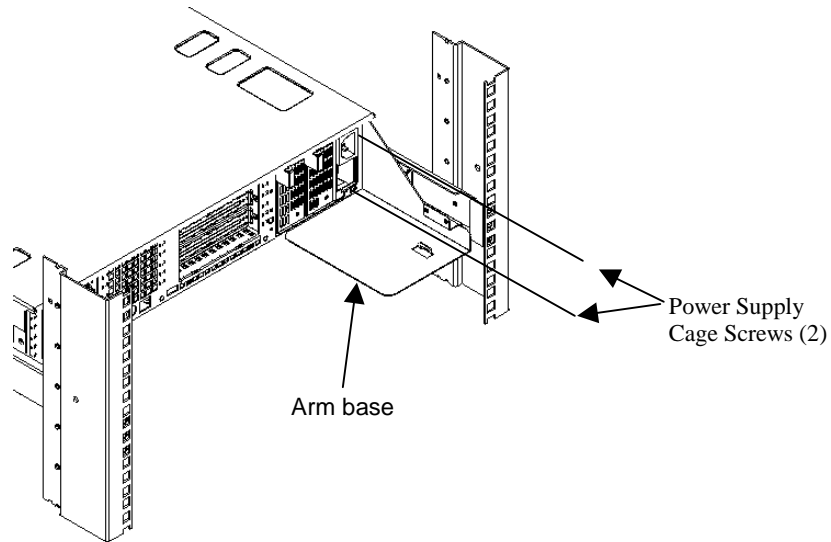

2. One end of the cable arm includes a long hinged bracket with six mounting holes. The other end of the cable arm includes a small hinged bracket with two mounting holes. Using two 6-32 screws attach the end of the cable arm with the long hinged bracket to the arm base installed in the previous step.

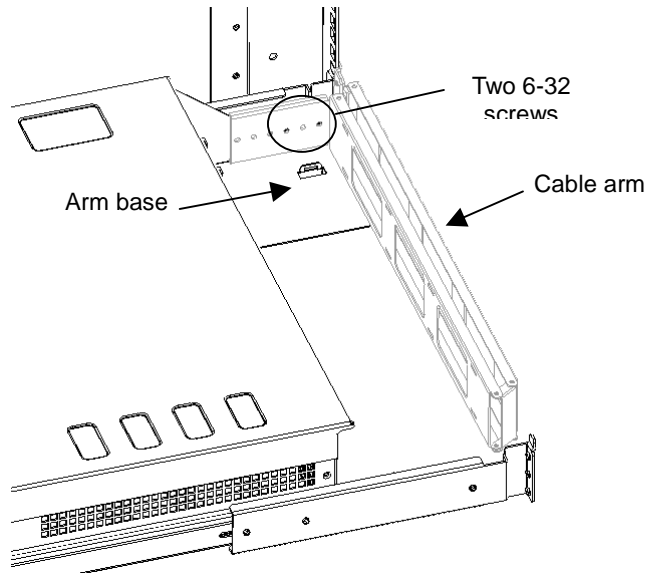

3. The arm bracket has four holes, two of which are elongated. Using the elongated holes in the arm bracket, attach the arm bracket onto arm stopper A using two 6-32 screws. Refer to the following illustration.
4. Using the upper rail bracket screw and one type B screw (see screw illustrations on page 3), attach the Arm stopper A bracket to the rear cabinet vertical rail.

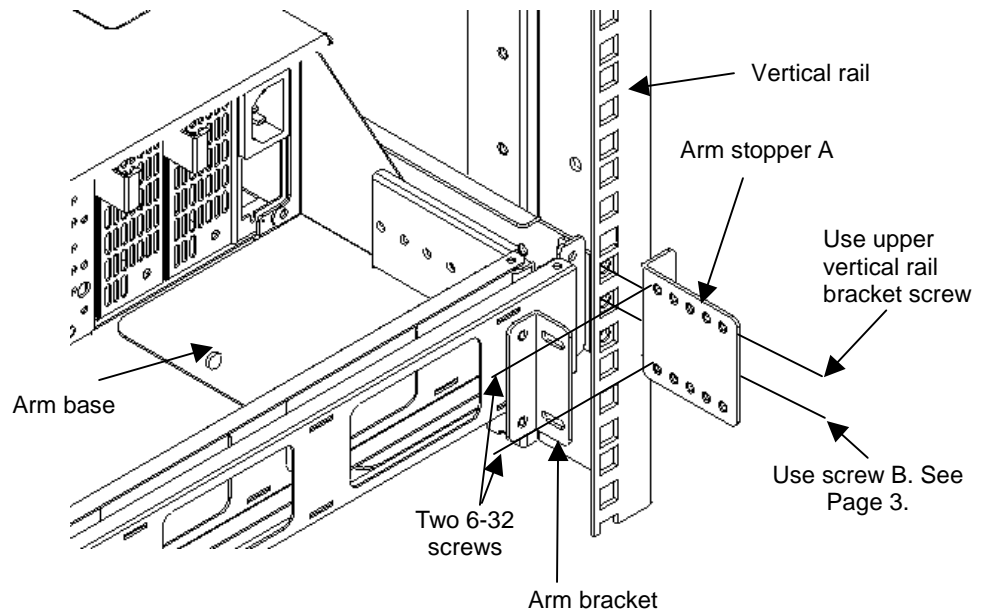

-
5. Install the free end of the cable arm to the arm bracket using two 6/32 screws.

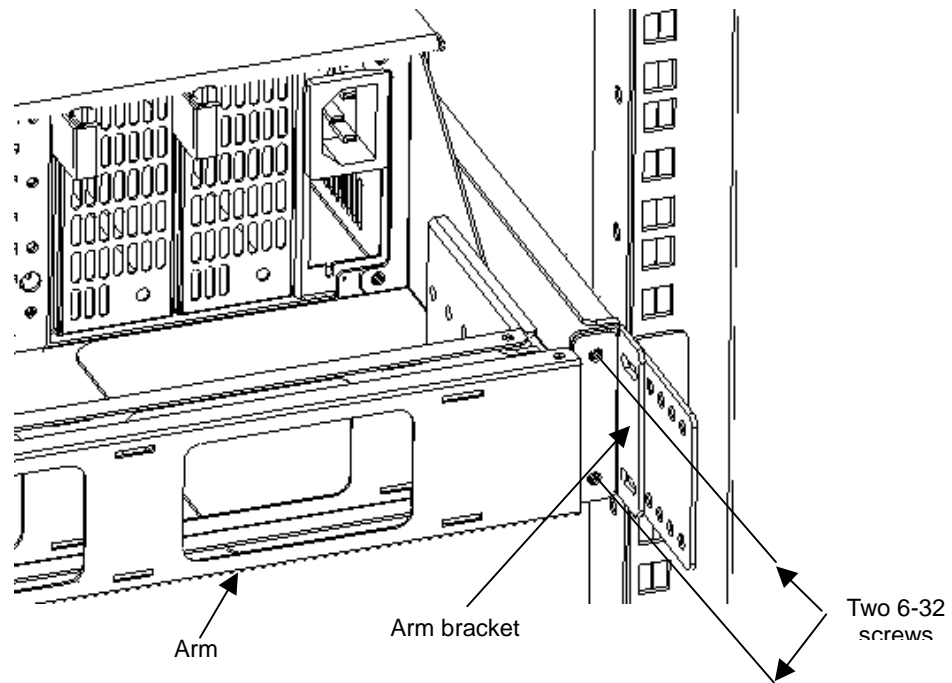

-
6. Press in on the rail release latches and slowly push the server in and out of the system rack several times. Ensure proper movement of the cable arm. Adjustment of the cable arm hinged brackets may be necessary to attain smooth operation. Tighten all screws. Ensure the server can be fully closed and secured to the rack.
 7. Bundle all the server cables together and tie-wrap them to the cable arm.

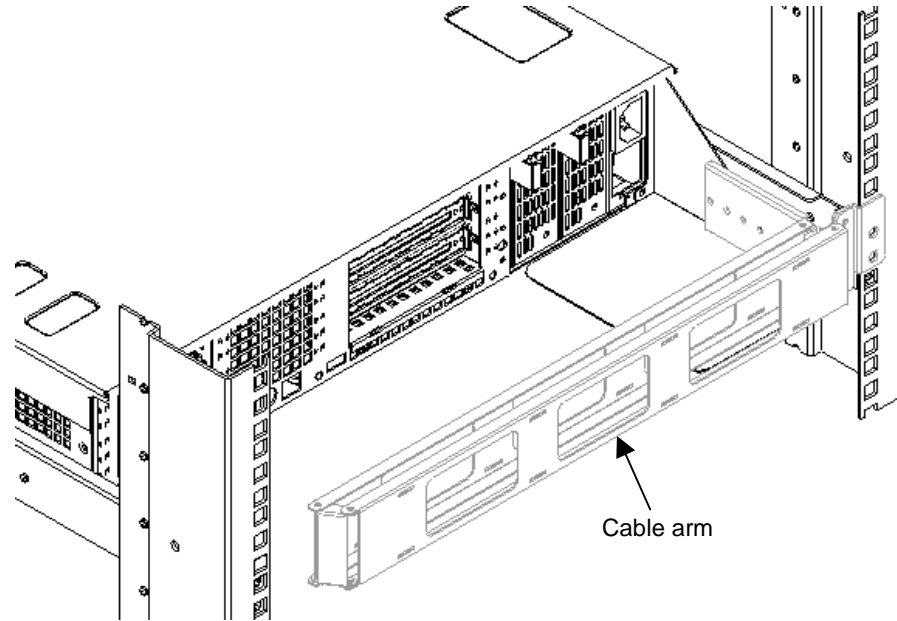

-
8. The Arm Stopper assembly keeps the cable arm from binding as the server is pulled out of or pushed into the rack. Attach the Arm Stopper assembly to the left rear vertical rail (viewed from the rear of the cabinet) using one Screw B and one screw rail bracket screw.

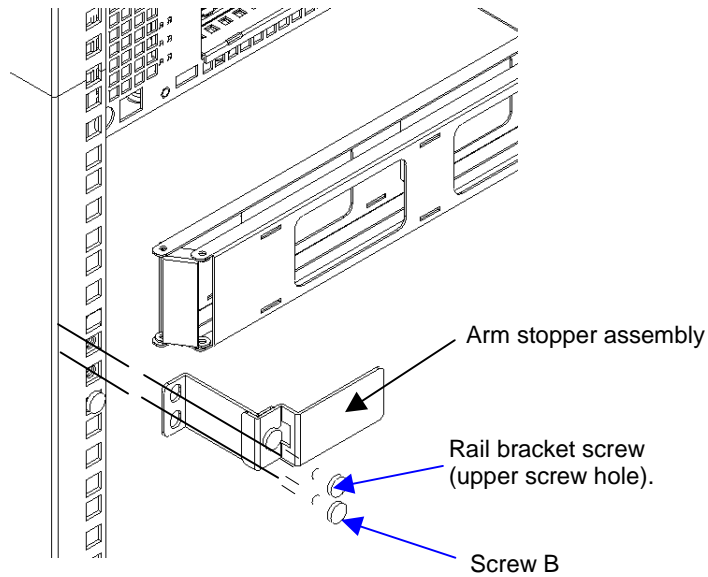

9. When installing or removing cables, loosen the fixed screw and separate the two pieces of the arm stopper assembly for easy access to the cable arm assembly. See the figure below.

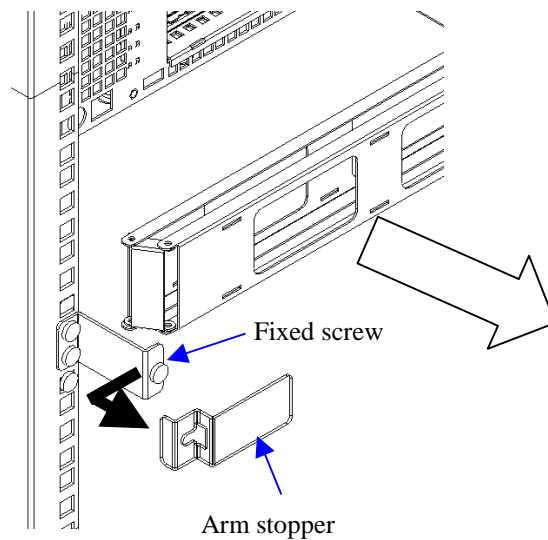

Installation Procedure B

1. Attach the Arm Base to the rear of the power supply cage using the two screws that secure the power supply cage to the chassis.

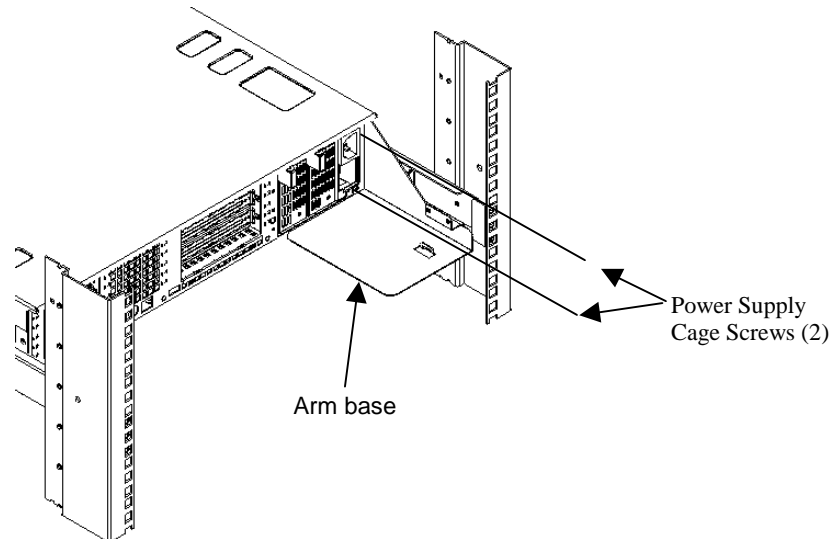

2. Position the Arm EX bracket as shown in the illustration below and using two 6-32 screws attach the Arm EX bracket to the Arm Base.
3. One end of the cable arm includes a long hinged bracket with six mounting holes. The other end of the cable arm includes a small hinged bracket with two mounting holes. Using two 6-32 screws attach the end of the cable arm with the long hinged bracket to the Arm EX bracket.

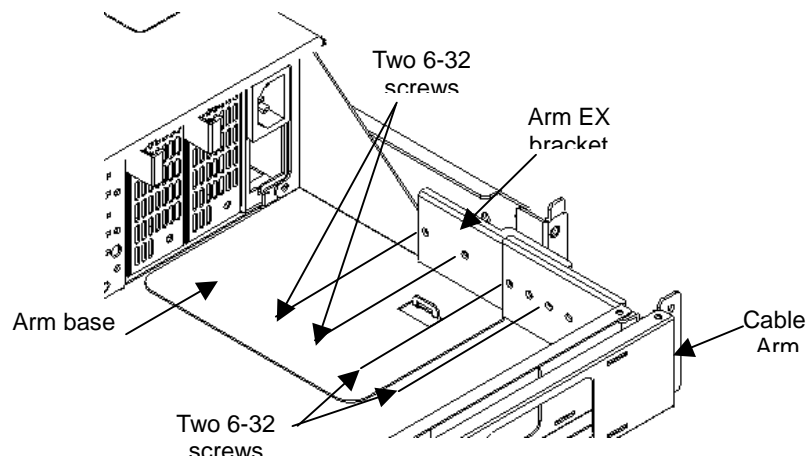

4. The arm bracket has four holes, two of which are elongated. Using the elongated holes in the arm bracket, attach the arm bracket onto arm stopper A using two 6-32 screws. Refer to the following illustration.
5. Using the upper rail bracket screw and one type B screw (see screw illustrations on page 3), attach the Arm stopper A bracket to the rear cabinet vertical rail.

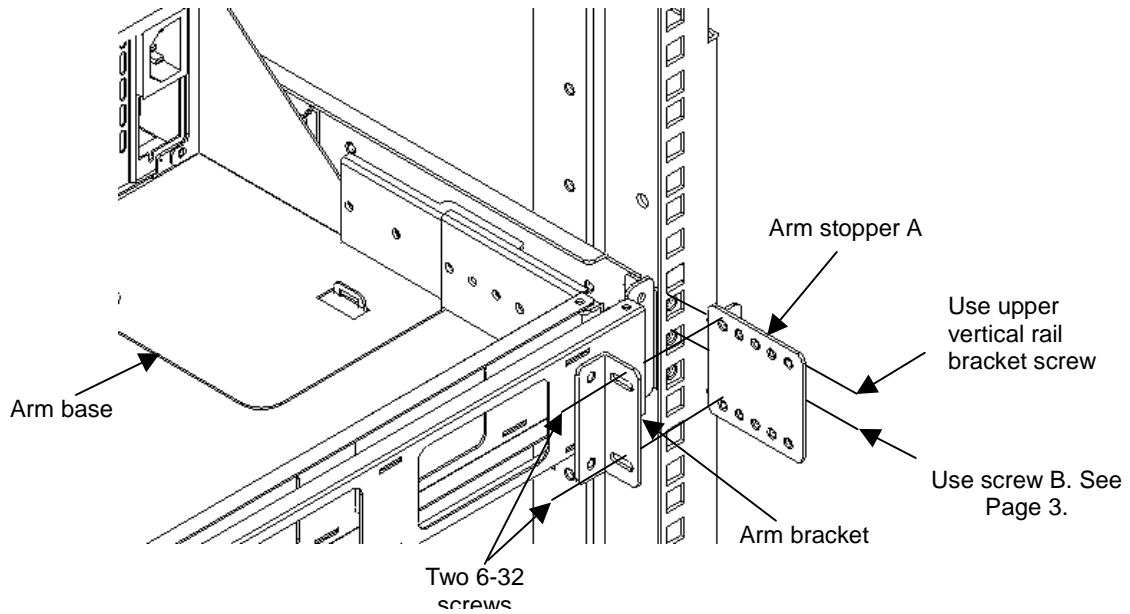

-
6. Install the free end of the cable arm to the arm bracket using two 6/32 screws.

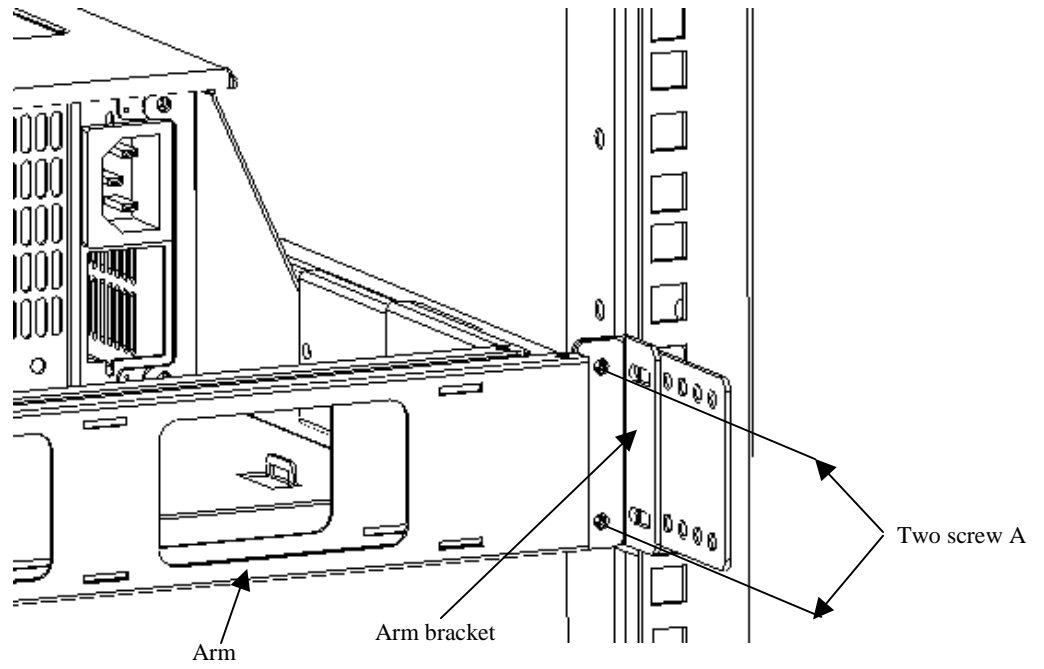

-
7. Press in on the rail release latches and slowly push the server in and out of the system rack several times. Ensure proper movement of the cable arm. Adjustment of the cable arm hinged brackets may be necessary to attain smooth operation. Tighten all screws. Ensure the server can be fully closed and secured to the rack.
 8. Bundle all the server cables together and tie-wrap them to the cable arm.

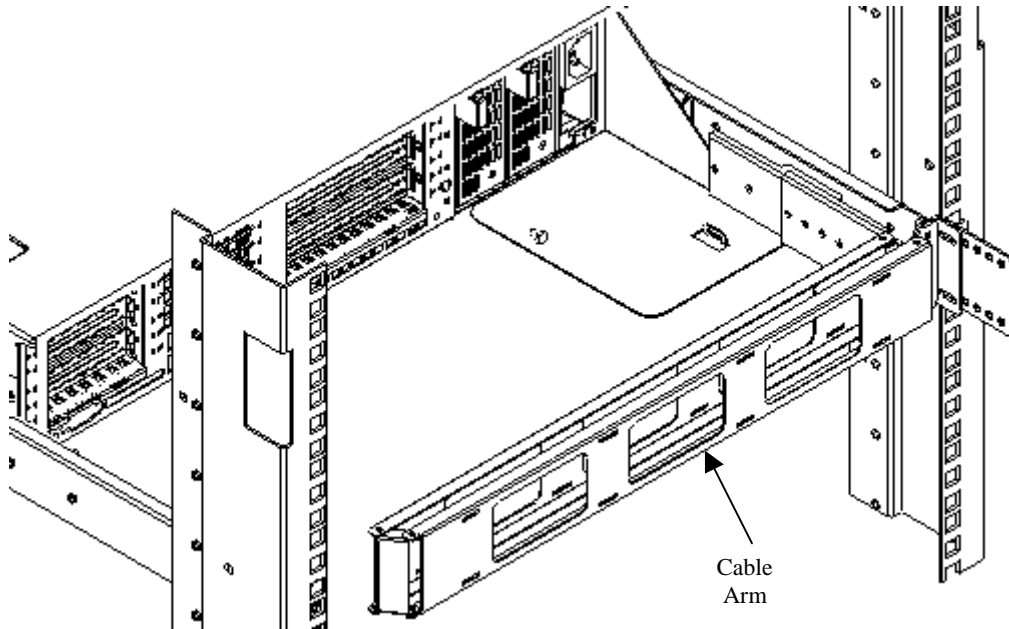

Installation Procedure C

1. Attach the Arm Base to the rear of the power supply cage using the two screws that secure the power supply cage to the chassis.

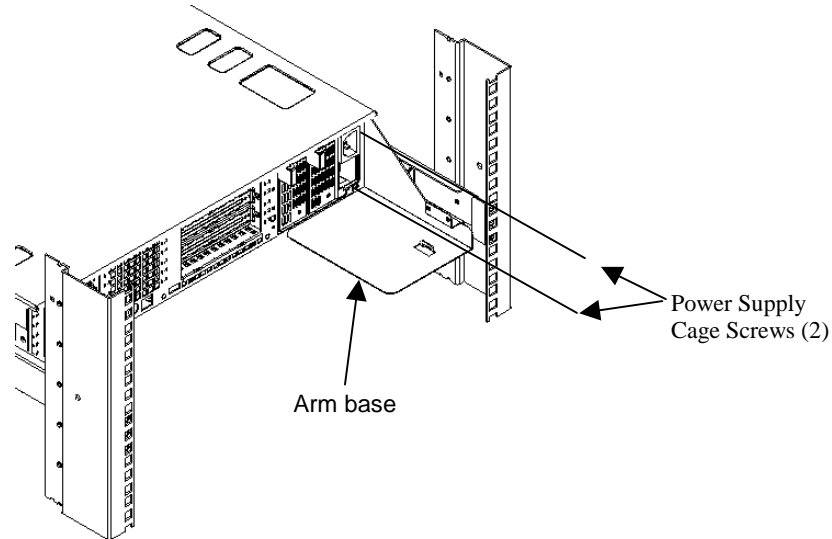

2. Position the Arm EX bracket as shown in the illustration below and using two 6-32 screws attach the Arm EX bracket to the Arm Base.
3. One end of the cable arm includes a long hinged bracket with six mounting holes. The other end of the cable arm includes a small hinged bracket with two mounting holes. Using two 6-32 screws attach the end of the cable arm with the long hinged bracket to the Arm EX bracket.

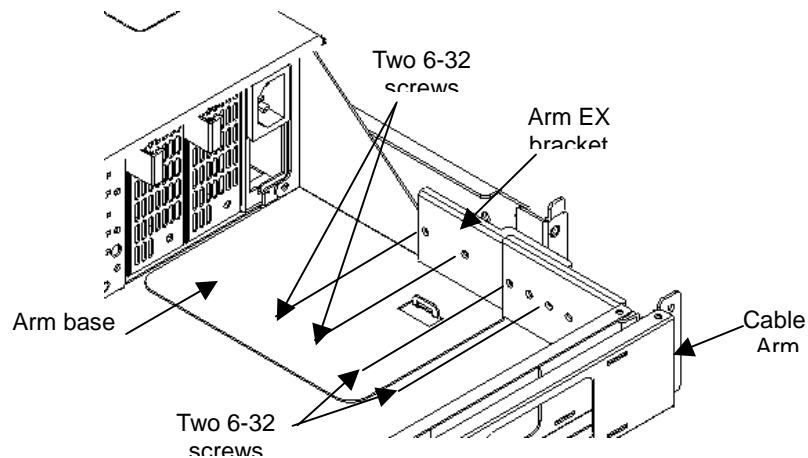

4. The arm bracket has four holes, two of which are elongated. Using the elongated holes in the arm bracket, attach the arm bracket onto arm stopper B using two 6-32 screws. Refer to the following illustration.
5. Using the upper rail bracket screw and one type B screw (see screw illustrations on page 3), attach the Arm stopper B bracket to the rear cabinet vertical rail.

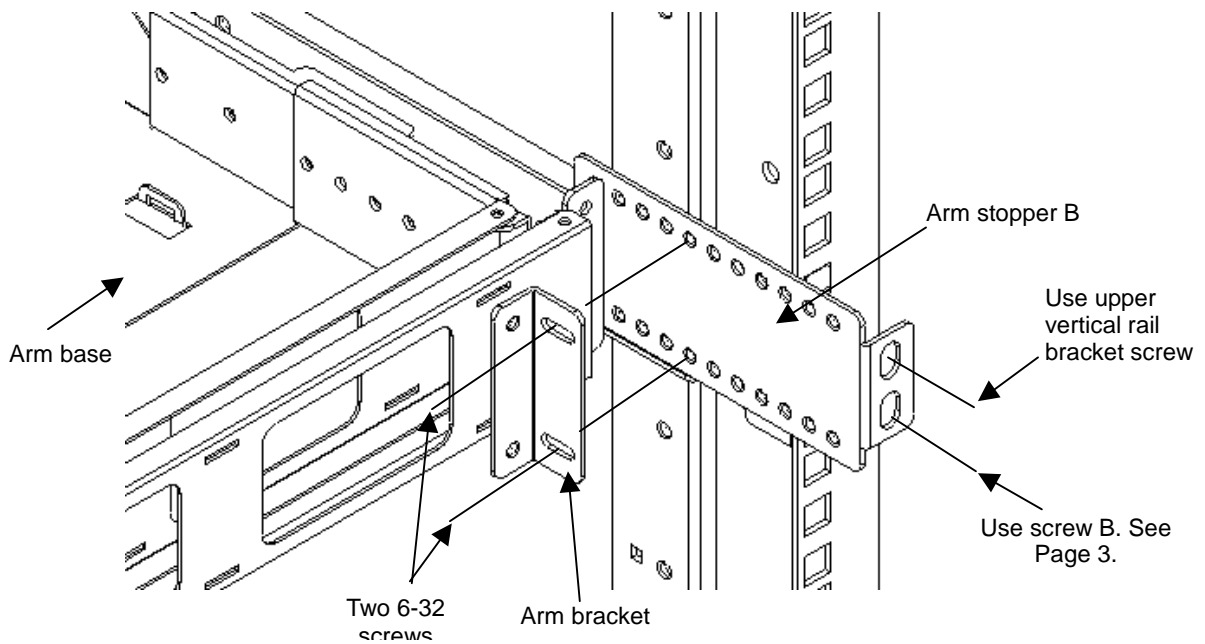

6. Install the free end of the cable arm to the arm bracket using two 6/32 screws.

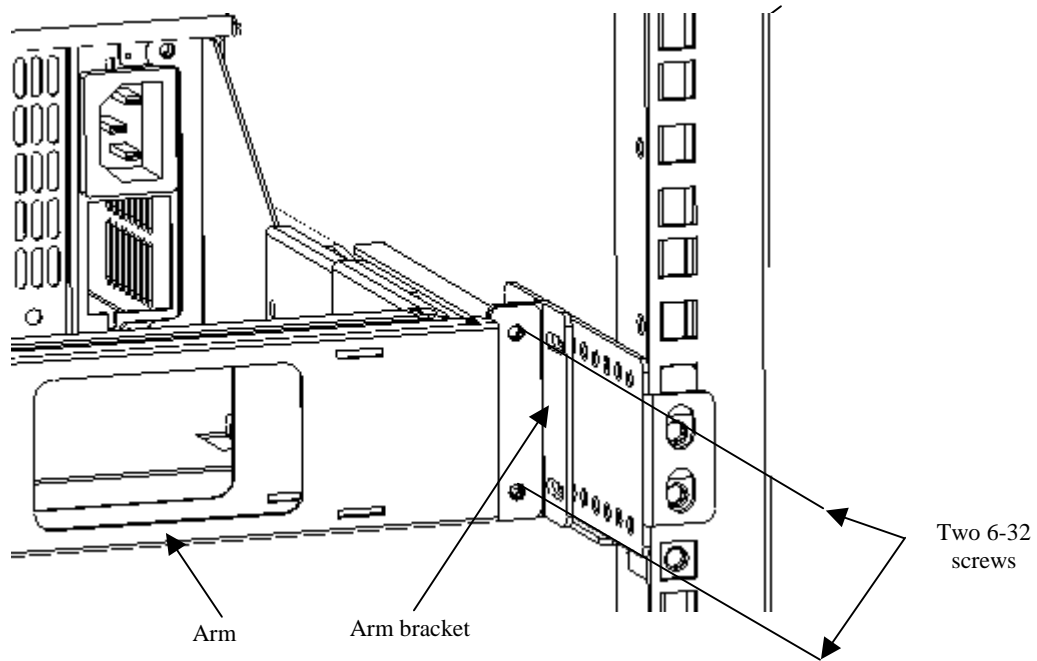

7. Press in on the rail release latches and slowly push the server in and out of the system rack several times. Ensure proper movement of the cable arm. Adjustment of the cable arm hinged brackets may be necessary to attain smooth operation. Tighten all screws. Ensure the server can be fully closed and secured to the rack.
8. Bundle all the server cables together and tie-wrap them to the cable arm.

