

Proprietary Notice and Liability Disclaimer

The information disclosed in this document, including all designs and related materials, is the valuable property of NEC Computers Inc. and/or its licensors. NEC Computers and/or its licensors, as appropriate, reserve all patent, copyright and other proprietary rights to this document, including all design, manufacturing, reproduction, use, and sales rights thereto, except to the extent said rights are expressly granted to others.

The NEC Computers product(s) discussed in this document are warranted in accordance with the terms of the Warranty Statement accompanying each product. However, actual performance of each such product is dependent upon factors such as system configuration, customer data, and operator control. Since implementation by customers of each product may vary, the suitability of specific product configurations and applications must be determined by the customer and is not warranted by NEC Computers.

To allow for design and specification improvements, the information in this document is subject to change at any time, without notice. Reproduction of this document or portions thereof without prior written approval of NEC Computers is prohibited.

NEC, PowerMate, and MultiSync are registered trademarks and AccuSync is a trademark of NEC Corporation or one of its subsidiaries. All are used under license.

Microsoft, Windows, Windows NT, and the Windows logo are registered trademarks of Microsoft Corporation.

Intel, Pentium, and LANDesk are registered trademarks of Intel Corporation.

All other trademarks and registered trademarks are the property of their respective trademark owners.

First Printing — May 2001

Copyright 2001
NEC Computers Inc.
15 Business Park Way
Sacramento, CA 95828
All Rights Reserved

Contents

Using This Guide

Text Conventions	x
Related Documents	xi

1 Reviewing System Features

Front Features	1-2
System Controls and Lamps	1-4
LCD Panel	1-5
Diskette Drive	1-5
CD-ROM Drive	1-6
Optional Combo Drive	1-6
Speakers	1-6
Right Side Features	1-7
Volume Control	1-7
Audio Connectors	1-8
Universal Serial Bus Ports	1-8
Hard Drive	1-8
Anti-theft Bracket	1-8
Left Side Features	1-9
PC Card Slots	1-9
System Unit Fans	1-10
Rear Features	1-10
PS/2 Mouse Port	1-11
Kensington Lock Slot	1-11
PS/2 Keyboard Port	1-11
Printer Port	1-11
Serial Port	1-11
LAN Connector	1-11
Optional Modem Connector	1-12
VGA Connector	1-12
DC Power Connector	1-12
Bottom Features	1-13
Memory Sockets	1-13
Password Clear Jumper	1-14
Microdesktop Chassis	1-14
System Overview	1-15
Hardware	1-15

Software.....	1-16
Preloaded Software.....	1-16
NEC Product Recovery CD	1-16
PowerMate Application and Driver CD.....	1-16
Security.....	1-17
2 Setting Up the System	
Cable Connections.....	2-2
Startup.....	2-2
Shutdown	2-3
Power-Saving Operation	2-4
System Care	2-5
Protecting Your System From Damage	2-5
Keeping Your System in Good Condition	2-6
Moving or Shipping Your System.....	2-7
More Information	2-8
3 Configuring the System	
Configuration Tools and Utilities	3-2
BIOS Setup Utility.....	3-4
How to Start Setup.....	3-4
How to Use Setup.....	3-4
Main Menu.....	3-6
Advanced Menu	3-12
Security Menu	3-17
Power Menu.....	3-21
Boot Menu	3-22
Exit Menu	3-24
Hard Drive Security.....	3-25
Establishing Hard Disk Drive Passwords.....	3-25
Changing Hard Disk Drive Passwords.....	3-26
Using Hard Disk Drive Password Protection	3-26
Moving the Hard Drive.....	3-27
FLASH Utility.....	3-28
NEC Customize Utility	3-28
PowerMate Application and Driver CD.....	3-29
NEC INFO Center	3-30
NEC Product Recovery CD.....	3-31
Performing Full Disk Restore.....	3-32
Performing Partition Only Restore	3-34
System Board Jumper Settings.....	3-36

Intel Processor Serial Number Control Utility.....	3-37
System Requirements.....	3-37
Installation.....	3-38
Processor Serial Number.....	3-38
Frequently Asked Questions.....	3-38
Technical Support.....	3-40
4 Adding Expansion Devices	
Safety Precautions.....	4-2
USB Devices	4-3
PC Cards	4-4
Inserting a PC Card.....	4-4
Removing a PC Card	4-6
Memory Modules.....	4-7
Checking System Memory.....	4-8
Installing a SO-DIMM Module	4-8
Removing a SO-DIMM Module.....	4-11
Hard Drive.....	4-12
Removing a Hard Drive	4-12
Installing a Hard Drive.....	4-14
Parallel Printer	4-15
External Monitor.....	4-15
Serial Devices.....	4-15
5 Solving System Problems	
Solutions to Common Problems	5-2
System Problems	5-2
Diskette Drive Problems	5-4
LCD Panel Problems.....	5-5
Keyboard/Mouse Problems	5-5
CD-ROM Drive Problems.....	5-6
Speaker Problems	5-7
How to Clean the Mouse	5-7
6 Getting Services and Support	
NEC Computers Web Site.....	6-2
NEC Computers FTP Site	6-3
Email/Fax Technical Support Service	6-3
NEC Computers Technical Support Services	6-4

A Setting Up a Healthy Work Environment

Making Your Computer Work for You.....	A-2
Arrange Your Equipment.....	A-3
Adjust Your Chair.....	A-4
Adjust Your Input Devices.....	A-6
Adjust Your Monitor.....	A-8
Vary Your Workday.....	A-10
Pre-existing Conditions and Psychosocial Factors.....	A-11
Checking Your Comfort: How Do You Measure Up?.....	A-11
Checking Your Chair.....	A-11
Checking Your Keyboard.....	A-12
Checking Your Mouse.....	A-12
Checking Your Monitor.....	A-12
Checking You.....	A-12

B System Specifications

System Board.....	B-2
System Processor.....	B-2
Random Access Memory (RAM).....	B-2
Cache Memory.....	B-2
Read Only Memory (ROM).....	B-2
Calendar Clock.....	B-2
Input/Output (I/O) Features.....	B-3
Video Memory.....	B-3
Sound Controller.....	B-4
Network Board.....	B-4
Modem Board.....	B-4
Graphics Controller.....	B-5
System Peripherals.....	B-5
LCD Panel.....	B-5
External Monitor.....	B-6
Keyboard.....	B-6
Mouse.....	B-7
Diskette Drive.....	B-7
Hard Drive.....	B-7
CD-ROM Drive.....	B-7
Combo Drive.....	B-8
PC Card Slots.....	B-8
Speakers.....	B-8

Dimensions.....	B-8
System.....	B-8
Keyboard.....	B-8
Power	B-9
Operating Environment.....	B-9
Compliance.....	B-9

Index

Regulatory Statements

Using This Guide

The *PowerMate® 2000 Series User's Guide* provides a comprehensive reference to information about your system.

The guide contains the following information:

- Chapter 1, *Reviewing System Features*, provides a look at the front, sides, rear, and bottom features of the system. It also gives a summary of the system's hardware, software, and security features.
- Chapter 2, *Setting Up the System*, briefly describes how to set up, start up, and shut down the system. The chapter also provides information on installing applications and tips on caring for the system.
- Chapter 3, *Configuring the System*, describes how to use the software shipped with your system, including the BIOS Setup Utility, FLASH Utility, NEC® Customize Utility, PowerMate® Application and Driver CD, NEC INFO Center, NEC Product Recovery CD, and Intel® Pentium® III Serial Number Control Utility. The chapter also includes information for setting the password jumper.
- Chapter 4, *Adding Expansion Devices*, provides installation procedures for adding expansion devices such as USB devices, PC cards, memory upgrade modules, hard drive, external monitor, and printer.
- Chapter 5, *Solving System Problems*, contains troubleshooting tips for solving simple problems and describes how to find help when you cannot solve a problem yourself.
- Chapter 6, *Getting Services and Support*, describes the services available to you for information and help, and describes how to access the services.
- Appendix A, *Setting Up a Healthy Work Environment*, contains guidelines to help you use your computer productively and safely. This appendix also instructs you on how to set up and use your computer to reduce your risk of developing nerve, muscle, or tendon disorders.
- Appendix B, *System Specifications*, provides a technical description of your system and its components.

 **WARNING** Prolonged or improper use of a computer workstation may pose a risk of serious injury. To reduce your risk of injury, set up and use your computer in the manner described in Appendix A, Setting Up a Healthy Work Environment.

Text Conventions

This guide uses the following text conventions.

- Warnings, cautions, and notes have the following meanings:

 **WARNING** Warnings alert you to situations that could result in serious personal injury or loss of life.

 **CAUTION** Cautions indicate situations that can damage the hardware or software.

Note Notes give important information about the material being described.

- Names of keyboard keys are printed as they appear on the keyboard, for example, **Ctrl**, **Alt**, or **Enter**.
- Text or keystrokes that you enter appear in boldface type. For example, type **abc123** and press **Enter**.
- File names are printed in uppercase letters. For example, AUTOEXEC.BAT.

Related Documents

In addition to this guide, the following printed documentation ships with your system.

- ***NEC PowerMate 2000 Series Quick Setup/Quick Reference***

The Quick Setup shows how to quickly get the system connected and powered on.

The Quick Reference briefly describes the documentation, NEC tools and utilities, software applications, and services available with the NEC PowerMate 2000 Series system.

- ***How Does Your Workplace Measure Up?***

This brochure provides information for setting up and using the computer productively and safely. Information includes guidelines to reduce the risk of injury associated with using a computer.

- ***NEC PowerMate 2000 Series Release Notes***

Release Notes provide additional information about the computer that was not available at the time the user's guide was printed. Information in the Release Notes is the result of product testing.

Your system also comes with the NEC INFO Center, an online guide to your PowerMate 2000 system. It provides information about the system through the following online modules: Tour, User's Guide, Questions, Solutions, and Services.

In addition to the documentation that ships with the system, documentation is available from the NEC Computers web site.

- ***NEC PowerMate 2000 Series Service and Reference Manual***

This manual provides information for maintaining, troubleshooting, and repairing the system. This manual also includes hardware and interface information for programmers, engineers, and others who need to know how the system is designed.

Service and reference manuals are available on the Internet at the Service and Support area of the NEC Computers web site (see Chapter 6 for access information).

- ***NEC PowerMate 2000 Series User's Guide***

Check the NEC Computers web site (Service and Support area) for the most current online version of your printed user's guide.

1

Reviewing System Features

- Front Features
- Right Side Features
- Left Side Features
- Rear Features
- Bottom Features
- Microdesktop Chassis
- System Overview

! WARNING Prolonged or improper use of a computer workstation may pose a risk of serious injury. To reduce your risk of injury, set up and use the computer in the manner described in Appendix A, "Setting Up a Healthy Work Environment."

This chapter highlights system hardware and software features, and describes system security features.

Front Features

The following figures show the features on the front of the system unit and the front of the liquid crystal display (LCD) panel. Brief descriptions of the features follow the figures.

PowerMate 2000 system

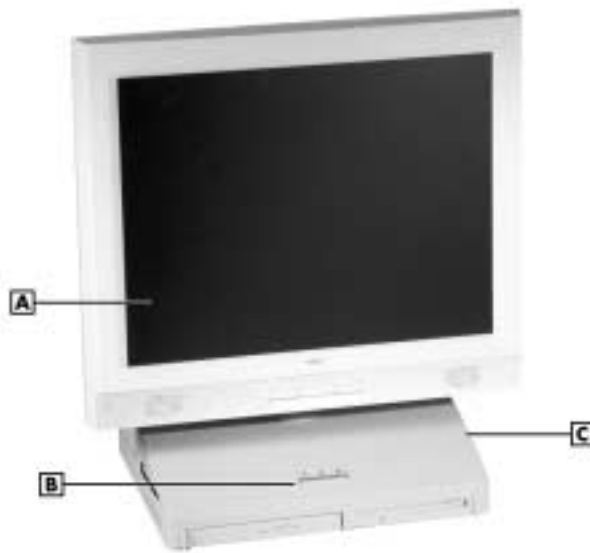

A – LCD Panel
B – Power/Sleep Button

C – System Unit

PowerMate 2000 system unit front features

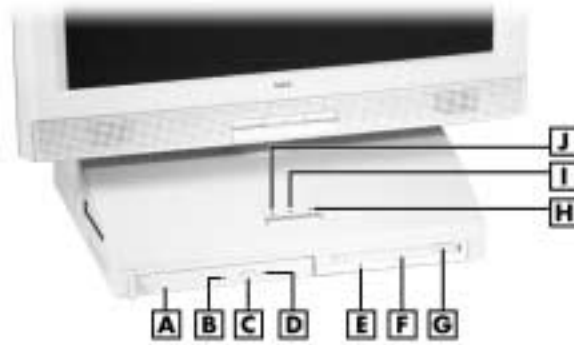

- | | |
|--|----------------------------------|
| A – CD-ROM Drive | F – Diskette Drive |
| B – CD-ROM Drive Lamp | G – Diskette Eject Button |
| C – CD-ROM Disc Eject Button | H – Hard Drive Lamp |
| D – CD-ROM Disc Emergency Eject | I – Power Lamp |
| E – Diskette Drive Lamp | J – Sleep Lamp |

PowerMate 2000 LCD panel features

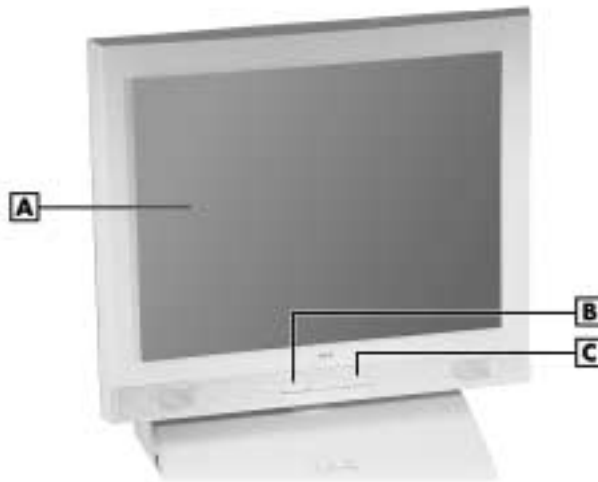

- | | |
|---|---|
| A – LCD Panel | C – Increase Brightness Level Button |
| B – Decrease Brightness Level Button | |

System Controls and Lamps

System unit controls include a power/sleep button, power lamp, sleep lamp, and hard drive activity lamp.

- **Power/sleep button**
To turn system unit and LCD panel power on, press the power/sleep button. To turn off power, press the button and hold in place for four or more seconds before releasing.

 **CAUTION** Do not turn off the system power until you have closed all applications and the Microsoft® Windows® operating system or you might lose data.

To suspend system unit and LCD panel operation, press the power/sleep button and release within three seconds. This places the system in a power savings mode. Use this feature if you plan to be away from your system for more than 15 minutes. If the system does not go into a power saving mode and shuts down, check the power management setting (see “Power-Saving Operation” in Chapter 2).

 **CAUTION** Do not hold the button in any longer than three seconds or you will turn off the system and possibly lose data.

Press any key or move the mouse to resume system operation at the point where you stopped it.

- **Power and sleep lamps**
The power lamp indicates if system power is on or off. The sleep lamp lets you know if the system is operating in a power-saving mode.

A steady green power lamp indicates that the power is on to all system components. An amber sleep lamp indicates that the system is in sleep mode with full-power reduction.
- **Hard drive activity lamp**
A flashing green lamp indicates that the hard drive is active and is reading or writing data.

 **CAUTION** Do not turn off the system unless absolutely necessary while the hard drive lamp is flashing. To do so can damage your hard drive or data.

LCD Panel

The system comes with an LCD panel that you can adjust up or down and side-to-side for a comfortable viewing position. The panel uses a 15-inch, twisted nematic Thin Film Transistor (TFT) Super Video Graphics Array (SVGA) color screen. The screen has a brightness of 200 candlepower and a maximum resolution of 1024 x 768 pixels.

The LCD panel screen automatically turns on when you press the system power button. If you have an optional video graphics array (VGA) monitor attached to the system, the monitor can be turned on for simultaneous viewing on the monitor and the LCD panel.

An increase brightness button and a decrease brightness button on the panel allows you to increase or decrease the brightness of the display. The buttons provide eight levels of brightness. The default brightness is maximum.

Note Powering off the system or unplugging the system from the power outlet changes any new brightness setting to the maximum default brightness.

Diskette Drive

Use the diskette drive to copy data files to and from a diskette. You can also use it as a bootable drive for loading and starting programs from a diskette.

A flashing green activity lamp on the front of the drive indicates that the drive is reading or writing data.

Press the eject button to eject a diskette.



CAUTION To prevent damage to the diskette drive and data, do not turn off the system or remove a diskette while the diskette drive busy lamp is flashing.

CD-ROM Drive

All systems come with a variable speed CD-ROM drive. Use the CD-ROM drive to load and start programs from a compact disc (CD). You can also use the CD-ROM drive to play your audio CDs.

The CD-ROM drive operates at different speeds depending on whether the CD you are using contains data or music. This allows you to get your data faster and to see smoother animation and video.

A flashing amber activity lamp on the front of the drive indicates that the drive is reading data. Press the tray button to open or close the CD-ROM tray for loading or unloading a CD. An emergency eject feature allows you to open the tray in case of a power or software malfunction.

Optional Combo Drive

Some systems might come with an optional variable-speed combo drive in place of the CD-ROM drive. The combo drive provides the functions of a CD-RW drive and a DVD-ROM drive in one unit.

Use the combo drive to load and start programs from CDs or to play audio CDs while you work or relax. With the Microsoft Windows 98 Second Edition (SE) or Windows 2000 operating system, you can play full-length CD-I movies and play movies in DVD format (DVD is not supported under the Windows NT[®] operating system). Use the drive to create data and audio CDs and to write information to a recordable or re-recordable CD.

Speakers

The system has two 1-watt stereo speakers mounted inside the base of the LCD panel. Speaker volume is controlled by the volume control on the right side of the system unit. Volume can also be controlled through the Microsoft Windows sound software.

Right Side Features

The following figure shows the features on the right side of the system unit. Brief descriptions of the features follow the figure.

PowerMate 2000 right side features

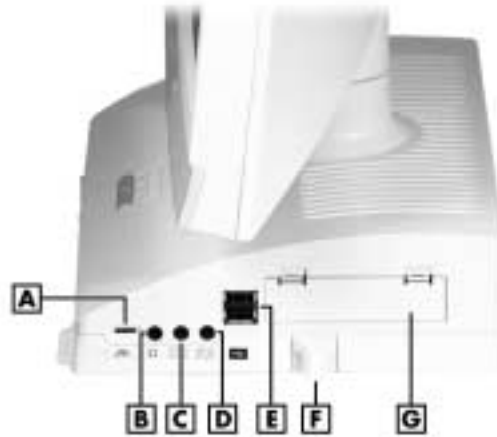

A – Volume Control
B – Headphone Jack
C – Line-In Jack
D – Microphone-In Jack

E – USB Connectors (2)
F – Cable Lock Bracket
G – Hard Drive Access Panel

Volume Control

Use the volume control to adjust the volume of the system's built-in speakers or optional headphone set. The speakers are located in the base of the LCD panel.

You can also use the Windows sound software. To bring up the Windows volume control, double click the speaker icon on the taskbar (next to the system clock). Use the software to balance the sound between the left and right speakers.

Audio Connectors

Your system unit has the following audio connectors:

- **Microphone-in jack**
Use this jack to connect a microphone for recording audio information in your data files.
- **Line-in jack**
Use this jack to connect a stereo audio device such as a stereo amplifier or a cassette for playback or recording.
- **Headphone jack**
Use this jack to connect an optional headphone set. Plugging in the headphone set disables the built-in system speakers.

Universal Serial Bus Ports

The system unit comes with two USB ports. The ports allow you to easily and conveniently add Plug and Play USB devices without opening up the system. You simply plug the USB device into a port. You can connect up to 127 USB devices including a keyboard, mouse, monitor, printer, scanner, or speaker set.

Hard Drive

The system comes with an enhanced intelligent device electronics (EIDE) hard drive. The drive features ultra direct memory access (DMA) 66 technology for fast data transfer. The drive also features Self-Monitoring, Analysis and Reporting (SMART[®]) technology.

The drive is located inside the system unit, behind the hard drive access panel on the right side.

Hard disk activity is indicated by a flashing green lamp on the front of the system unit.

Anti-theft Bracket

Your system comes with an anti-theft bracket installed on the right side of the system unit, below the hard drive access panel. Secure your mouse and keyboard cables within the anti-theft bracket to make it difficult to remove the cables from the system.

Left Side Features

The following figure shows the features on the left side of the system unit. Brief descriptions of the features follow the figure.

PowerMate 2000 left side features

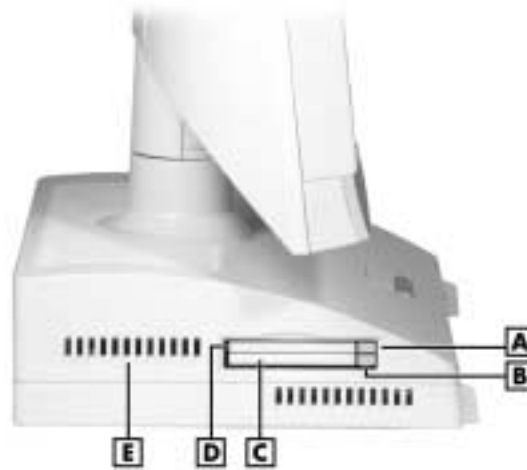

- | | |
|-------------------------------------|------------------------------|
| A – Slot 1 Card Eject Button | D – PC Card Slot 1 |
| B – Slot 2 Card Eject Button | E – Fan (behind vent) |
| C – PC Card Slot 2 | |

PC Card Slots

Your system has two PC Card slots that support 32-bit CardBus technology and 16-bit PC Card technology. The CardBus technology provides up to 132 MB/second of bandwidth.

The card slots support two Type II PC Cards or one Type III PC Card in the bottom slot for extending the system's capabilities. Each type of PC Card has a different function. Using the PC Card slots, you can add a number of functions to the system with a variety of cards, including a modem, memory, and Small Computer System Interface (SCSI).

A PC Card is inserted into a PC Card slot similar to inserting a diskette in a diskette drive. Press the eject button to eject a PC Card. Removable slot covers keep foreign matter out of the slots when PC Cards are not used.

System Unit Fans

The system's two fans cool system unit components to prevent them from overheating. Keep the area near the fan vents clear for proper ventilation. The fans are inside the system unit, and the vents are on the left side and top of the unit.

Rear Features

On the rear of the system unit, you'll find connectors for your mouse, keyboard, printer, serial device, monitor, and LAN (or optional modem). You'll also find a Kensington[®] lock slot and a DC power connector. These features are described in the following sections.

Depending on your system's configuration, an optional mounting bracket might be installed at the rear of the system unit. Use the bracket to secure the system to a solid object (for example, to a wall).

PowerMate 2000 rear features

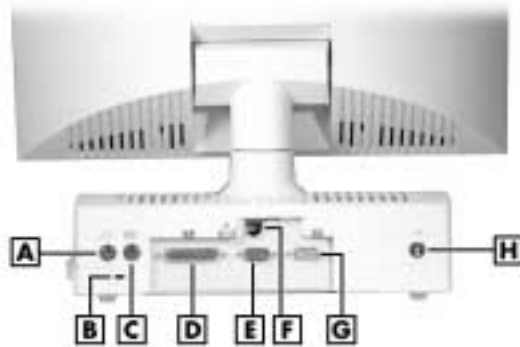

- | | |
|---------------------------------|--|
| A – PS/2 Mouse Port | E – Serial Port |
| B – Kensington Lock Slot | F – LAN (or optional modem) Connector |
| C – PS/2 Keyboard Port | G – VGA Connector |
| D – Printer Port | H – DC Power Connector |

PS/2 Mouse Port

The system unit comes with a mouse port that supports a personal system/2[®]-compatible (PS/2-compatible) mouse with a 6-pin mini DIN connector.

Use this port to connect the PS/2 mouse shipped with your system.

Kensington Lock Slot

The lock slot on the rear of the system accepts a Kensington Security Standard connector or other locking device.

Use this slot and a locking device to secure your system to an immovable object.

PS/2 Keyboard Port

Your system unit comes with a keyboard port that supports a standard PS/2 101-key or 104-key keyboard with a 6-pin mini DIN connector.

Use this port to connect the PS/2 keyboard shipped with your system.

Printer Port

Use this port to connect a parallel printer with a 25-pin connector to the system unit. The port is an enhanced capabilities port (ECP). It also supports enhanced parallel port (EPP), bi-directional, and uni-directional protocols.

Serial Port

Attach a serial device with a 9-pin connector to this serial port. Serial devices include a pointing device, serial printer, or a modem.

LAN Connector

Systems come with a Mini PCI local area network (LAN) board. Use the RJ-45 compatible LAN connector on the rear of the system to connect a network cable to the internal 100Base-TX/10Base-T network board.

Optional Modem Connector

Some systems might come with an optional Mini PCI V.90 56K modem board in place of the LAN board. Use the modem connector on the rear of the system to connect your telephone line to the system.

VGA Connector

The system unit comes with a VGA connector on the rear of the system unit.

Use this connector to connect an optional NEC MultiSync® monitor, NEC AccuSync™ monitor, or other VGA-compatible monitor with a 15-pin connector. You can also attach a projector with a 15-pin connector to this connector.

The system supports simultaneous use of the LCD panel and an optional monitor connected to the VGA connector.

DC Power Connector

The system operates with DC power supplied from the AC power adapter. The adapter plugs into an AC power source and the DC power connector at the rear of the system unit. The AC power adapter uses a standard 115-Vac or 230-Vac grounded power source.

Bottom Features

A panel on the bottom of the system unit covers the two memory expansion sockets and the password clear jumper. (See Chapter 4, “Adding Expansion Devices,” for information on removing the panel.)

PowerMate 2000 bottom features

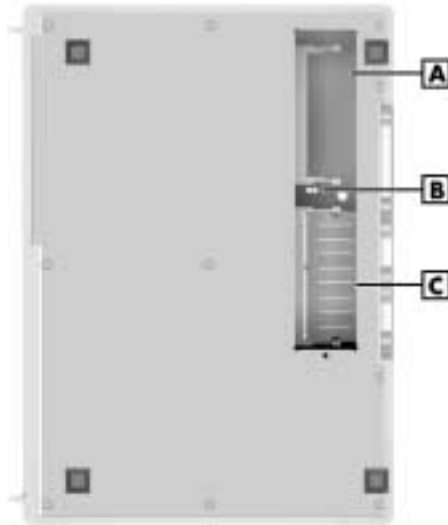

A – SO-DIMM Socket 1
B – Password Clear Jumper

C – SO-DIMM Socket 0

Memory Sockets

The system unit comes standard with one 128-MB small outline dual-inline memory module (SO-DIMM) mounted in one of the system’s memory sockets.

You can increase system memory up to a maximum of 512 MB by using 64-MB, 128-MB, and 256-MB modules (see “Adding Memory Modules” in Chapter 4).

The modules use synchronous dynamic random access memory (SDRAM). Memory allocation is controlled by Dynamic Video Memory Technology (DVMT). With DVMT, total system memory is shared between system memory and video memory. For example, with 128 MB of total system memory, 112 MB might be allocated for system memory and 16 MB for video memory, with actual memory use dependent on video usage.

Password Clear Jumper

Use the password clear jumper to clear your password if you forgot it. To clear and reset the password, see “Jumper Settings” and “Security Menu” in Chapter 3.

Microdesktop Chassis

The NEC Microdesktop chassis conforms to NEC’s Very-Small Form Factor and Flat Panel Display Specification. The microdesktop has the following features:

- small size chassis that is 85 percent smaller and correspondingly lighter than traditional desktops
- 15-inch LCD panel with 1024 x 768 pixel maximum resolution, eight levels of display brightness, horizontal viewing angle of 60 degrees from center to right or left side of panel, vertical viewing angle of 40 degrees from center of panel and upwards, and 50 degrees from center of panel and downwards
- 80-watt power supply built into the AC power adapter
- bracket (optional) for securing the system to a wall or other solid object.

System Overview

The system hardware and software deliver the performance and technologies needed for all your challenging tasks today and into the future.

Hardware

The PowerMate 2000 system includes the following hardware features:

- **PC99 Compliance**
All the hardware in the system is certified by Microsoft to be PC99 compliant.
- **Processor**
The system comes with an Intel® Pentium® III 933-MHz or higher processor (133-MHz or higher front side bus). The processor is a fast, powerful processor that lends itself to computational, graphical, and networking tasks.
- **Audio**
The system board comes with an integrated audio subsystem. The audio chipset gives you a surround sound system for three-dimensional sound effects. It also provides wavetable synthesis.
- **Flashable ROM BIOS**
The system's ROM BIOS features system setup configuration, plug and play support, and flash support for economical BIOS upgrades.
- **System and Video Memory**
Your system comes standard with 128 MB of non-ECC PC100 SDRAM and supports up to 512 MB of total system memory. The memory uses DVMT technology which allows system memory to be shared with video memory.
- **AGP Graphics**
The system comes with a 4-MB Direct Accelerated Graphics Port (AGP) integrated on the system board. Direct AGP enhances graphics performance, particularly for 3-D applications.
- **Power Management Options**
Power management options extend the life of your LCD panel, conserve energy, and reduce power costs.

Software

NEC provides a variety of software applications and hardware utilities with your system to let you take advantage of your hardware capabilities.

Preloaded Software

Your system comes preloaded with the Microsoft Windows 98 SE operating system or with the Windows 2000/Windows NT 4.0 operating system.

If you have a Windows 2000/Windows NT configuration, you must choose the operating system you want to load. The operating system you choose is your only operating system and is the one that the NEC Product Recovery program restores.

The system also comes preloaded with the Intel Processor Serial Number Control Utility. Use this utility to enable or disable the reading of the Intel Pentium III processor serial number.

NEC Product Recovery CD

Your system comes with an NEC Product Recovery CD. Should a problem occur that causes data loss or corruption, you can use the NEC Product Recovery CD to restore the system to its original factory state. A system restore loads the operating system and the factory-supplied software that comes with the system. See “NEC Product Recovery” in Chapter 3 for information about using the restore options.

PowerMate Application and Driver CD

Use the PowerMate Application and Driver CD to install NEC Computers provided applications, drivers, and utilities on your hard drive. Also use the PowerMate Application and Driver CD to reinstall NEC Computers supplied software. See “PowerMate Application and Driver CD” in Chapter 3 for information about installing software from the CD.

NEC Computers software available on the PowerMate Application and Driver CD includes the following applications:

- Microsoft Internet Explorer Browser
Internet Explorer provides a top-notch browser with preloaded links for easy access to the world wide web. Also use Internet Explorer to access one of the many new browser-based utilities.

-
- Norton AntiVirus™ Software
Protect the system from viruses by running Norton's virus scan software.
 - Adobe® Acrobat® Reader
Use the Adobe Acrobat Reader to read and print portable document format (PDF) files found on the Internet and PDF documents included with various software applications.
 - NEC INFO Center
Get quick access to comprehensive information about your system in the online NEC INFO Center. NEC INFO modules include Tour, User's Guide, Questions, Solutions, and Services. See "NEC INFO Center" in Chapter 3 for a description of the documentation and how to use the INFO Center.
 - Intel LANDesk® Client Manager
Use LANDesk software to track system information such as serial number, BIOS version, memory capacity, disk capacity, expansion board settings, and applications. Use LANDesk software for remote starts from a server computer using Wake-On LAN and remote reboot.

Security

The system has hardware, software, and mechanical security features that offer protection against unauthorized access to your system and data. The following security features are available with the system.

- Password Security
The BIOS Setup utility includes a feature that lets you set a user or supervisor password, or both.

The user password controls booting of the system and controls access to the Setup Utility and the keyboard. (User access to the BIOS Setup Utility is limited to a subset of all BIOS Setup parameters when a supervisor password has been set.)

The supervisor password allows full access to the system and the BIOS.

-
- **Security Lock Slot**
The security lock slot on the rear of the system accepts a Kensington Security Standard connector or other locking device. Secure the locking device to the security lock slot and to an immovable object to protect your system from theft.
 - **Anti-theft Bracket**
The anti-theft bracket can be used to secure your mouse and keyboard cables. Securing the cables in the bracket makes them difficult to remove from the system.
 - **Hard Drive Security**
Your system supports password protection for the hard drive. Hard drive password protection restricts access to the drive if the drive is removed and installed in another system. The system does not prompt for hard drive passwords while the drive remains in the current system.

The passwords are written to the system BIOS and to the hard drive to ensure that the password protection travels with the hard drive in the event it is moved to another system. (See “Hard Drive Security” in Chapter 3 for additional information on using this feature.)

- **Windows Network Security**
To learn more about the network security features available through the Windows operating system, refer to your Windows documentation or consult your system administrator.

2

Setting Up the System

- Cable Connections
- Startup
- Shutdown
- Power-Saving Operation
- System Care
- More Information

This chapter provides basic information for setting up and using your system (refer to the Quick Setup poster for details). Included are cable connections, system startup procedures, system shutdown procedures, and system care. The chapter also includes a table showing where to find additional information about your system.

Cable Connections

After unpacking the system (save the carton) and positioning the system in your work area, connect the system components using the Quick Setup poster and the following tips.

- Use the icons on the rear and side of the system unit to identify the USB, keyboard, mouse, LAN, modem (if installed), printer, monitor, power, and audio connectors.
- See your network administrator for guidelines on configuring the LAN.
- Connect the system AC adapter power cord to a surge protector (recommended) or a properly grounded wall outlet and to the DC power connector at the rear of the system unit.



CAUTION NEC Computers recommends connecting the AC adapter power cord to a surge protector to protect your system.

Startup

Press the power button to turn on the system unit and LCD panel. The power lamp lights green to indicate that the system is on. The system performs its Power-On Self-Test (POST) and several messages appear on the screen indicating that the system is checking its subsystems.

Note At the bottom of the NEC startup screen, the following message appears: **Press F2 to enter BIOS Setup**. If you want to enter the BIOS Setup Utility, immediately press **F2** while the startup screen displays. (See Chapter 3, "Configuring the System," for information on using the BIOS Setup.)

After a short delay, the Microsoft Windows operating system starts up.

If a problem occurs, a series of beeps might sound. If this happens repeatedly after powering on, power off the system and go to Chapter 5, “Solving System Problems.” The chapter provides helpful hints for solving system problems.

If the system displays a message indicating that system settings have changed, run the BIOS Setup Utility (see Chapter 3, “Configuring the System”).

On systems with the Microsoft Windows 2000 operating system, enter your password at the log-on box. On systems with the Microsoft Windows NT 4.0 operating system, press **Ctrl Alt Del** when prompted to do so. Enter your password at the log-on box.

Shutdown

Follow these steps to power off the system.

 **CAUTION** To prevent damage to system components, wake a system in sleep mode, save and close any open applications, exit Windows, and power down the system.

1. If the system is in sleep mode (sleep mode lamp amber), move the mouse or press a key to take it out of sleep mode (see “Power Saving Operation” in the next section).
2. Save your work and exit all open applications.
3. Make sure that the hard drive, diskette drive, and any other drives are not in use. A lit device lamp indicates that the device is in use.

 **CAUTION** Wait until all open applications are saved and closed before using the Windows operating system shut down procedure in step 4.

Unless absolutely necessary, never power off the system if the system sleep lamp is amber (sleep mode), if either the hard drive lamp, diskette drive, or other device lamp is flashing, or if any applications are open. Information on the device might be lost or damaged.

-
4. Click **Start** on the taskbar and click **Shut Down**. Select **Shut down the computer**, then click **Yes** or press **Enter** for shut down, depending on your operating system.
 - If the system is configured with Windows 98 or Windows 2000, the system shuts down automatically after a short interval.
 - If the system is configured with Windows NT, perform a Windows shut down, then power off the system by pressing and holding in the power button for four seconds or longer.

Power-Saving Operation

If the system is running Windows 98 or Windows 2000, you can put it in sleep mode (a power-saving state) by pressing and immediately releasing the power button on the front of the system unit. The sleep mode conserves energy when you are going to be away from your system for more than 15 minutes. If the system does not go into sleep mode, check that the sleep mode is enabled in power management. Click **Start**, point to **Settings**, click **Control Panel**, double click **Power Management (Power Options** for Windows 2000), and click **Advanced**. Select **Standby** in the **Power buttons** drop-down menu.



CAUTION Take care to press and immediately release the power button to enter the sleep mode. Avoid pressing and holding in the power button longer than three seconds or you may turn off power and possibly lose data from any open applications.

The system also goes into sleep mode when it has been inactive, if the power management has been enabled, and an inactivity timeout has been enabled. To see if power management is enabled, click **Start**, point to **Settings**, click **Control Panel**, double click **Power Management (Power Options** for Windows 2000), click **Power Schemes**, and check the settings.

When the system goes into sleep mode, it automatically saves data and system status and then shuts off power to all possible components. Sleep mode lets you save power without first saving your work.

An amber sleep lamp and blank screen indicates that the system is in sleep mode. Press a key or move the mouse to resume system operation where you left off.

System Care

The system is a durable system built for dependable use. With protective measures and proper care, you can prevent problems and promote the successful operation and long life span of the system.

Protecting Your System From Damage

There are several ways that you can protect the system from possible damage. NEC Computers strongly recommends the following protective measures.

- Connect a surge suppressor between the system and a grounded wall outlet. A surge suppressor protects the system from sudden transient increases and decreases in electrical power.

Be sure to connect all peripherals, such as a printer, to the surge suppressor. The surge protector should be the only device that you plug into the wall outlet.

- Avoid repeated power-on cycles. These subject the system components to temperature variations and stress.
- Disconnect the system from telephone and power lines when an electrical storm threatens. If you have a fax/modem, lightning can travel in on the phone line and damage both the fax/modem and the system unit. Lightning can also travel in on power lines and damage the LCD panel and system unit.
- Except for USB devices, ensure that system power is off before connecting or disconnecting a cable; otherwise damage to the system and its peripherals might occur. USB devices do not require powering down the system when connecting or disconnecting a device.
- Use your Norton virus scan protection software regularly to protect the system from viruses.

If you plan to load software programs other than the ones NEC Computers has supplied on the PowerMate Application and Driver CD, NEC Computers strongly recommends that you take the necessary steps, such as backing up your system and performing virus checks, to protect the system and your data.

-
- Position the system away from direct sunlight and extreme hot and cold temperatures.

The recommended operating environment is from 50°F to 95°F (10°C to 35°C).

The recommended non-operating environment (shipping or storage) is from 14°F to 158°F (-10°C to 70°C).

- After turning off power, wait about five seconds for the hard drive to spin down before you power on again.
- Be sure that nothing is placed on top of the system's AC adapter and power cord.
- Prevent dust from entering the system by covering it when not in use.

Keeping Your System in Good Condition

Maintain the condition of your system by periodically using the following procedures.



WARNING For safety, power off and unplug your system and any external devices before cleaning them.

- Clean the outside of the system unit and LCD panel (but not the screen) with a soft clean cloth.

Remove stubborn stains with a cloth slightly dampened with a mild detergent. Never use a strong cleaner or solvent on any part of the system.

- Clean the LCD panel screen with a soft, lint-free cloth or a screen wipe designed for that purpose. Special screen wipes are available through your local computer dealer.
- Keep food and liquids away from the system.
- Periodically clean the keyboard with a vacuum cleaner brush attachment and vacuum cleaner specially designed for computer use. Do not use any liquid cleaners on the keyboard as they can damage the keyboard.

If an object, such as a paper clip, falls into the keyboard, turn the keyboard over and gently shake it.

2-6 *Setting Up the System*

Moving or Shipping Your System

Use these steps to prepare the system for moving or shipping.

1. Back up your files on the hard drive to diskettes, server hard drive, or other backup devices.

Take precautions for storing and transporting storage media so that they are not exposed to magnetic fields or electrical impulses.

2. Remove any diskette from the diskette drive. If you have a CD in the drive, remove the CD.
3. Remove any PC Cards from the card slots on the left side of your system unit. Install the slot covers.
4. Wake up a system in sleep mode, save and close any open applications, shut down the Windows operating system, and turn off the system unit and any external options connected to it.
5. Unplug the system AC adapter power cord from the wall outlet or surge suppressor and the AC adapter from the system unit.
6. Unplug any external options from the wall outlets or surge suppressor, then disconnect them from the system unit.
7. Pack the system components in the original shipping materials and cartons. If these are not available, be sure to use adequate packing materials to protect the components.

Note Be sure to save the original shipping materials in the unlikely event that you need to ship the system back for repair.

To set up the system, follow the steps on the *PowerMate 2000 Quick Setup* poster that comes with the system.

More Information

Once the system is up and running, we suggest that you do the following.

- See “Setting Up a Healthy Work Environment” in Appendix A.
- Install applications provided by NEC Computers on the PowerMate Application and Driver CD.
- Install any of your own applications. See the documentation that comes with the application.

See the following quick reference table to find information about using your system.

Quick Reference to Information About Your System

Information	Where to Find It
Accessing the world wide web	Chapter 6
Adding expansion devices	Chapter 4
Guidelines for using your system	Appendix A
Installing the applications provided by NEC Computers	“PowerMate Application and Driver CD” in Chapter 3
Protecting the system from viruses	Chapter 1
Setting a password	Chapter 3
System specifications	Appendix B
Taking care of the system	“System Care” in Chapter 2
Troubleshooting tips	Chapter 5
Using support services	Chapter 6
Using the NEC INFO Center online documentation	“NEC INFO Center” in Chapter 3

3

Configuring the System

- Configuration Tools and Utilities
- BIOS Setup Utility
- Hard Drive Security
- FLASH Utility
- NEC Customize Utility
- PowerMate Application and Driver CD
- NEC INFO Center
- NEC Product Recovery CD
- System Board Jumper Settings
- Intel Processor Serial Number Control Utility

This chapter provides information on configuring your system. The chapter includes information on:

- Phoenix® Technologies Ltd. BIOS Setup Utility for configuring your system
- hard drive security for password protection of the internal hard drive
- FLASH Utility for BIOS updates
- NEC Customize Utility for launching the Application and Driver CD
- NEC INFO Center for quick access to information about your system
- PowerMate Application and Driver CD for installing drivers and software
- NEC Product Recovery CD for restoring the operating system
- jumper settings for clearing your password, should you forget it
- Intel Processor Serial Number Control Utility for controlling the reading of the processor serial number.

See the following table for a quick guide to the utilities, tools, or procedures required for configuring the system. For detailed information about these and other tools, see the sections following the table.

Configuration Tools and Utilities

The following table lists ways you can configure the system, and the utility, tool, or procedure to use for the configuration.

Configuration Tools and Utilities

Configuration	Method, Tool, or Utility
BIOS, updating	FLASH Utility
Boot devices, determining	BIOS Setup (Boot Menu)
Boot order, changing	BIOS Setup (Boot Menu)
Clearing password	Jumper Settings
Diskette drive, enabling	BIOS Setup (Main Menu)
Drivers for NEC Computers hardware	PowerMate Application and Driver CD

3-2 Configuring the System

Configuration Tools and Utilities

Configuration	Method, Tool, or Utility
Hard drive, reformatting	NEC Product Recovery CD
Hard drive, setting a pre-delay	BIOS Setup (Power Menu)
Inactivity timeout, setting	BIOS Setup (Power Menu)
Keyboard options	BIOS Setup (Main Menu)
Memory, checking	BIOS Setup (Main Menu)
NEC INFO Center	See "NEC INFO Center"
Operating system, restoring	NEC Product Recovery CD
Parallel port, enabling, configuring	BIOS Setup (Advanced Menu)
Password, setting or clearing (user, supervisor, or both)	BIOS Setup (Security Menu) Jumper settings
Plug and Play, enabling	BIOS Setup (Advanced Menu)
Power management, enabling, configuring	BIOS Setup (Power Menu)
Serial ports, enabling	BIOS Setup (Advanced Menu)
SO-DIMM memory, checking	BIOS Setup (Main Menu)
Software provided through NEC Computers, installing	NEC Product Recovery CD
Sound, enabling	BIOS Setup (Advanced Menu)
Time and date, setting	BIOS Setup (Main Menu)
USB functions	BIOS Setup (Advanced Menu)
Microsoft Windows 98 SE, Windows 2000, or Windows NT operating system, restoring	NEC Product Recovery CD

BIOS Setup Utility

The BIOS Setup Utility lets you configure the main components of your system. The utility is resident in the system FLASH memory and does not require a diskette or an operating system present to run.

Your system ships from the factory with the correct system parameters for your configuration. Unless you add optional hardware, you do not need to run the BIOS Setup Utility to operate your system. However, you might wish to run the BIOS Setup Utility to set features that customize your system, such as security features.

NEC Computers recommends that you print out or write down your current BIOS Setup parameters and store the information in a safe place. This lets you restore your system to the current parameters if you need to have the CMOS battery replaced.

How to Start Setup

To start the BIOS Setup Utility, follow these steps.

1. Turn on or reboot the system.
2. Press **F2** at the NEC startup screen.
 - You have about five seconds to press **F2**.
 - Setup's Main Menu window appears.

How to Use Setup

The Setup utility has a Main Menu window and six top-level menus with submenus. The menu bar at the top of the Main Menu window lists the following top-level menus.

- **Main** — Use the Main Menu for basic system configuration. For example, select Main to set the system date, set diskette and hard disk parameters, check memory parameters, or set the processor serial number feature.
- **Advanced** — Use the Advanced Menu to configure the system for Plug and Play, PCI, cache memory, I/O device, large disk access, local bus IDE adapter, quick boot, sound, DMI event logging, and preboot management.

-
- Security — Use this menu to set User and Supervisor Passwords, security mode, password on boot, network boot, virus check, and system backup reminder.
 - Power — Use the Power Menu to set power management parameters such as power savings, auto suspend timeout, hard disk timeout, system switch, resume on modem ring, resume on time, and resume time.
 - Boot — Use this menu to set boot options, including restore on ac/power loss, power management, set boot sequence, and assign drive letters to removable devices.
 - Exit — Exits the Setup Utility with various save or discard options.

Use the keys listed in the legend bar on the bottom of the Setup Menu to make the selections or exit the current menu. The following table describes the legend keys.

Setup Key Functions

Key	Function
F1	Provides help for the parameter field being displayed.
Esc	Exits the menu.
Up or down arrow keys	Moves cursor up and down for item selection.
Left or right arrow keys	Selects next menu.
-/+ keys	Changes values.
Enter	Executes a command or selects submenu.
F9	Loads the default configuration values for the current menu.
F10	Saves the current values and exits Setup.

To select one of the six menus from the menu bar, use the left and right arrow keys. Use the up or down arrow keys to select an item under the menu.

Menu items preceded by a > contain a submenu of selectable fields for setting system parameters. Display a submenu by using the up or down arrow keys to move the cursor to the desired submenu, then press **Enter**.

An Item Specific Help window on the right side of each menu displays the help text for the currently selected Setup option. It updates as the cursor moves to each new field.

Pressing **F1** on any menu brings up the General Help window that describes the legend keys and their functions.

Press **Esc** to exit the current window.

The following subsections describe the six top level menus and their submenus.

Main Menu

Choose the Main Menu by selecting Main in the legend bar on the Main Menu screen. Other Main Menu options are available by selecting submenus.

Use the arrow keys to select one of the Main Menu options and press **Enter** to select a submenu. Items with grayed-out text are not available. Explanations of each Main Menu item are in the following table.

 **CAUTION** Setting items on this menu to incorrect values can cause your system to malfunction.

Note The following menu information is typical for a system with a hard drive and a CD-ROM drive. The actual settings on your menu screens depend upon the hardware installed in your system.

Main Menu Items

Menu Item	Settings (default is bold)
System Time	Set system time in this field. Press Tab or Enter to move between hour, minute, and second fields. Example: 09:30:50
System Date	Set system date in this field. Press Tab or Enter to move between month, date, and year fields. Example: 04/26/2001
Language	English (US) , Japanese Selects the display language for the BIOS.
Legacy Diskette A	Disabled 360 KB 5 1/4" 1.2 MB 5 1/4" 720 KB 3 1/2" 1.44/1.25 MB 3 1/2" 2.88 MB 3 1/2" Selects the diskette drive type.

Main Menu Items

Menu Item	Settings (default is bold)
Primary IDE Master	xxxxx MB
Primary IDE Slave	None
Secondary IDE Master	CD-ROM
Secondary IDE Slave	None

Note: The following setting information applies to the primary and secondary master and slave devices.

Each device menu item displays the hard drive or CD-ROM identifier if a device is installed.

If you install a hard drive that does not feature auto IDE type detection or your IDE hard drive was formatted on another system with parameters different from those reported by the drive, enter a parameter for each of the fields in the device submenu.

Bring up a device submenu by pressing **Enter**. The submenus include Type, CHS Format, and LBA Format. Each submenu and its fields are described next.

Main Menu Items

Menu Item	Settings (default is bold)
Type	<p>User, Auto, None, CD-ROM, IDE/ATAPI Removable, Other ATAPI</p> <p>When set to Auto, the values for Cylinders, Heads, Sectors, Total Sectors, and Maximum Capacity are displayed but are read only.</p> <p>When set to Auto, the BIOS detects what the drive is capable of, not the translation mechanism that was used to format the drive. If a drive is run in a mode other than the mode in which it was partitioned and formatted, unpredictable results might occur, including data loss.</p> <p>When set to None, informs the system to ignore this drive.</p> <p>When set to CD-ROM, IDE/ATAPI Removable, or Other ATAPI, allows the manual entry for multi-sector transfers, LBA mode control, 32-bit I/O transfer mode, ultra DMA mode, and SMART monitor.</p> <p>When set to User, allows the manual entry of all the following fields.</p> <p>CHS Format (label field only)</p>
Cylinders	<p>When Type is Auto, value in the Cylinders field is auto-detected and field is read only.</p>
Heads	<p>When Type is Auto, value in Heads field is auto-detected and field is read only.</p>
Sectors	<p>When Type is Auto, value in Sectors field is auto-detected and field is read only.</p>
Maximum Capacity	<p>xxxx MB</p> <p>LBA Format (label field only)</p>
Total Sectors	<p>xxxxxxxx total sectors</p>
Maximum Capacity	<p>xxxxx MB</p>

Main Menu Items

Menu Item	Settings (default is bold)
Multi-Sector Transfers	Disabled, 2, 4, 8, 16 sectors Determines the number of sectors per block for multi-sector transfers. When Type is Auto, value in Multi-Sector Transfers field is auto-detected and field is read only.
LBA Mode Control	Enabled , Disabled When Enabled is selected, it causes logical block addressing to be used in place of cylinders, heads, and sectors. When Type is set to Auto, the value in the LBA Mode field is auto-detected and the field is read only.
32-Bit I/O	Disabled , Enabled When Enabled, allows 32-bit data transfers.
Transfer Mode	Standard, Fast PIO1 , Fast PIO2 , Fast PIO3 , Fast PIO4 , PIO3/DMA1 , PIO4/DMA2 Selects the method for moving data to and from the drive. When Type is set to Auto, the value in the field is auto-detected and the field is read only.
Ultra DMA Mode	Disabled, Mode 0 , Mode 1 , Mode 2 Selects the Ultra DMA Mode for moving data to and from the drive. Autotype the drive to select the optimum transfer mode. When Type is set to Auto, the value in the field is auto-detected and the field is read only.

Main Menu Items

Menu Item	Settings (default is bold)
Keyboard Features	Press Enter to check or change keyboard parameters.
Numlock	Auto , On, Off Selects the power-on state for Numlock.
Key Click	Disabled , Enabled Enables or disables key click.
Keyboard auto-repeat rate	30/sec , 26.7/sec, 21.8/sec, 18.5/sec, 13.3/sec, 10/sec, 6/sec, 2/sec Selects key repeat rate.
Keyboard auto-repeat delay	1/4 sec, 1/2 sec , 3/4 sec, 1 sec Selects delay before key repeat.
Legacy USB Support	Disabled, Enabled Disables or enables legacy USB support.
USB Packet Size	8, 64 Selects data packet size for BIOS at first detection of USB devices.
Boot-Time Diagnostics Screen	Disabled , Enabled Selecting Enabled displays the diagnostic screen during boot.
System Memory	Displays amount of conventional memory detected during boot. This field is read-only and cannot be changed from BIOS Setup. Example: 640 KB

Main Menu Items

Menu Item	Settings (default is bold)
Extended Memory	Displays amount of extended memory detected during boot. This field is read-only and cannot be changed from BIOS Setup. Example: 129024 KB
BIOS Revision	Displays the BIOS revision number. This field is read-only and cannot be changed from the BIOS Setup. Example: 183A0800
Processor Serial Number	Disabled , Enabled Controls detection of the processor serial number.

Advanced Menu

Choose the Advanced Menu by selecting Advanced in the legend bar on the Main Menu screen. Other Advanced Menu options are available by selecting submenus.

Use the arrow keys to select one of the Advanced Menu options and press **Enter** to select a submenu. Items with grayed-out text are not available. Explanations of each Advanced Menu item are in the following table.

 **CAUTION** Setting items on this menu to incorrect values can cause your system to malfunction.

Advanced Menu

Menu Item	Settings (default is bold)
Plug and Play OS	No, Yes Select Yes if you are booting a Plug and Play capable operating system. Select No if you want the BIOS to configure non-boot devices.
Reset Configuration Data	No , Yes Select Yes if you want to clear the Extended System Configuration Data (ESCD) area.
PCI Configuration	Press Enter to access the following submenus.
PCI IRQ Line 1 = 10	Disabled, Auto Select, 3, 4, 5, 7, 9, 10, 11, 12, 14, 15 Use Auto Select if there are no ISA or EISA devices installed on the system. Select an IRQ (3-15) if installing a PCI device requiring an IRQ and if the IRQ is not already in use by ISA or EISA devices.
PCI IRQ Line 2 = 5	
PCI IRQ Line 3 = 10	
PCI IRQ Line 4 = 5	
Cache Memory	Press Enter to access the following submenus.
Memory Cache	Disabled, Enabled Sets the state of the memory cache.
Cache System BIOS Area	Uncached, Write Protect Controls caching of system BIOS area.
Cache Video BIOS Area	Uncached, Write Protect Controls caching of system video BIOS area.

Advanced Menu

Menu Item	Settings (default is bold)
Cache Base 0-512K	Uncached, Write Through, Write Protect, Write Back Controls caching of 512K base memory.
Cache Base 512-640K	Uncached, Write Through, Write Protect, Write Back Controls caching of 512K-640K base memory.
Cache Extended Memory Area	Uncached, Write Through, Write Protect, Write Back Controls caching of system memory above one MB.
Cache C800-CBFF Cache CC00-CFFF Cache D000-D3FF Cache D400-D7FF Cache D800-DBFF Cache DC00-DFFF	Disabled , Write Through, Write Protect, Write Back Setting at Disabled prohibits caching. Setting at Write Through permits writes to be cached and sent to main memory at once. Setting at Write Protect causes the BIOS to ignore writes. Setting at Write Back permits write caching but delays sending data to main memory until necessary.

Advanced Menu

Menu Item	Settings (default is bold)
I/O Device Configuration	Press Enter to access the following submenus.
Serial Port A	Disabled, Enabled , Auto Setting at Enabled allows the user to configure the port. Setting at Auto enables the BIOS or operating system to configure the port.
Base I/O Address	3F8 , 2F8, 3E8, 2E8 Selects the base I/O address for serial port A.
Interrupt	IRQ3, IRQ4 Selects the IRQ for serial port A.
Parallel Port	Disabled, Enabled , Auto Setting at Enabled allows the user to configure the port. Setting at Auto enables the BIOS or operating system to configure the port.
Mode	Output Only, Bi-directional , ECP Selects parallel port mode.
Base I/O Address	378 , 278, 3BC Selects the base I/O address for the LPT port.
Interrupt	IRQ5, IRQ7 Selects the IRQ for the LPT port.

Advanced Menu

Menu Item	Settings (default is bold)
Floppy Disk Controller	Disabled, Enabled , Auto Setting at Enabled allows the user to configure the controller. Setting at Auto enables the BIOS or operating system to configure the controller.
Base I/O Address	Primary , Secondary Sets the base I/O address for the controller.
Large Disk Access Mode	Other, DOS Select DOS if using DOS operating system. Select Other if using another operating system such as UNIX or Novell NetWare.
Local Bus IDE Adapter	Disabled, Primary, Secondary, Both Enables the integrated local bus IDE adapter.
QuickBoot Mode	Disabled, Enabled When Enabled, the BIOS does not test system memory above 1 MB or wait for ready signals, allowing a quick boot.
Sound	Enabled , Disabled Select Disabled to turn off onboard sound.
DMI Event Logging	Press Enter to access the following submenus.
Event Log Capacity	Status only.
Event Log Validity	Status only.
View DMI Event Log	Status only, press Enter to view.

Advanced Menu

Menu Item	Settings (default is bold)
Clear All DMI Event Logs	No , Yes Selecting No prevents clearing out the DIMM event logs.
Event Logging	Enabled , Disabled Selecting Enabled permits logging of DMI events.
Mark DMI Events As Read	Press Enter . Select Yes or No to "Mark all Events as read?"
LANDesk ® Service	Disabled, Enabled Select Enabled to enable the onboard LANDesk.
Preboot Management	Disabled , Enabled Select Enabled to enable the Preboot Management function.

Security Menu

Choose the Security Menu by selecting Security in the legend bar on the Main Menu screen. Other Security Menu options are available by selecting submenus.

Use the arrow keys to select one of the Security Menu options and press **Enter** to select a submenu. Items with grayed-out text are not available. Explanations of each Security Menu item are in the following table.

Security Menu Items

Menu Item	Settings (default is bold)
Supervisor Password Is	Clear , Set Status only, user cannot modify. Supervisor password controls access to the BIOS Setup Utility.
User Password Is	Clear , Set Status only, user cannot modify. User password controls access to the system at boot.
Set Supervisor Password	Press Enter to access. Use this field to set or change the supervisor password. Press Enter to bring up a dialog box where the password can be entered and confirmed.
Set User Password	Press Enter to access. Use this field to set or change the user password. Press Enter to bring up a dialog box where the password can be entered and confirmed.

Security Menu Items

Menu Item	Settings (default is bold)
Security Mode	<p>Press Enter to access the Security Mode.</p> <p>Use this mode to select Password (default), SmartCard, or FingerPrint. Press Enter to open the selected field.</p> <p>Use the SmartCard field to assign access to the SmartCard Reader by the supervisor and/or user. Press Enter to bring up the SmartCard Reader dialog box for setting up SmartCard security.</p> <p>The Assign Supervisor SmartCard field controls Supervisor access to the BIOS Setup utility and the system. A PIN number controls access.</p> <p>The Assign User SmartCard field controls user access to the system at boot. A PIN number controls access.</p>
Password on Boot	<p>Disabled, Enabled</p> <p>When Enabled, requires password entry before boot. System remains in secure mode until password is entered.</p>
Fixed Disk Boot Sector	<p>Normal, Write Protect</p> <p>Write Protect protects the boot sector on the hard disk from viruses.</p>
Diskette Access	<p>Supervisor, User</p> <p>Controls access to the diskette drive.</p>

Security Menu Items

Menu Item	Settings (default is bold)
Network Boot Setting	Press Enter to access.
Keyboard/Mouse Lock	Disabled, Enabled Select Enabled to lock the keyboard and mouse when remote booting.
Virus Check Reminder	Disabled , Daily, Weekly, Monthly Displays reminder message at bootup. Message is daily, every Monday, or first of every month.
System Backup Reminder	Disabled , Daily, Weekly, Monthly Displays reminder message at bootup. Message is daily, every Monday, or first of every month.
Assign HDD Password	Press Enter to access the Assign HDD Password Mode. Controls access to the system's hard drive by assigning master and user passwords. See "Hard Drive Security" later in this chapter for information and procedures for using the HDD password mode. CAUTION: If the master and user password are set on a hard drive, they can never be removed. If the master password is forgotten and the hard drive is installed in another system, data cannot be accessed on the hard drive. Once these passwords are set, NEC Computers Inc. has no capacity to remove them.
Primary Master HDD Password	Disabled , Enabled Indicates state of master HDD password.

Power Menu

Choose the Power Menu by selecting Power in the legend bar on the Main Menu screen. Other Power Menu options are available by selecting submenus.

Use the arrow keys to select one of the Power Menu options and press **Enter** to select a submenu. Items with grayed-out text are not available. Explanations of each Power Menu item are in the following table.

Note Power management is only supported in systems running the Windows 98 or Windows 2000 operating system.

Power Menu Settings

Menu Item	Settings (default is bold)
Power Savings	Disabled, Customized , Maximum Power Savings, Maximum Performance Disabled setting turns off Power Management. Maximum Power Savings setting conserves the greatest amount of power. Maximum Performance setting conserves power but allows best system performance. Customized setting allows the user to modify the Auto Suspend Timeout and Hard Disk Timeout fields.
Auto Suspend Timeout	Off , 5, 10, 15, 20, 30, 40, 60 minutes Specifies the amount of time the system is in standby before entering the sleep mode.
Hard Disk Timeout	Disabled , 10, 15, 30, 45 seconds 1, 2, 4, 6, 8, 10, 15 minutes Specifies the amount of time the hard drive needs to be inactive before it is turned off.

Power Menu Settings

Menu Item	Settings (default is bold)
System Switch	Sleep Button, Power Button Select Power Button to turn the system on or off.
Resume On Modem Ring	Off , On Setting to On allows the system to wake up when an incoming call is detected on the modem (if installed).
Resume On Time	Off , On Setting to On allows the user to set the Resume Time field to a time when the system is to wake up.
Resume Time	00:00:00 When Resume on Time is set to On, the user can specify the time the system is to wake up.

Boot Menu

Choose the Boot Menu by selecting Boot in the legend bar on the Main Menu screen. Other Boot Menu options are available by selecting submenus.

Use the arrow keys to select one of the Boot Menu options and press **Enter** to select a submenu. Items with grayed-out text are not available. Explanations of each Boot Menu item are in the following table.

Boot Menu Settings

Menu Item	Settings (default is bold)
Restore On AC/Power Loss	Power Off , Last State, Power On Power Off setting keeps power off until power button is pressed. Last State setting restores the previous state before power loss occurred. Power On setting restores power to the system.
On PME	Stay Off , Power On Controls how system responds to a PCI Power Management Enabled wake-up.
1 through 4	Sets the bootable device order. Use the up or down arrow to select a device, then press the + or – key to move the device up or down the list.
Hard Drive	Press Return System attempts to boot from the first hard drive in this list. If no operating system found, system tries the next drive until operating system is found. Boot order can be changed. Use the up or down arrow to select a device, then press the + or – key to move the device up or down the list.

Boot Menu Settings

Menu Item	Settings (default is bold)
Removable Devices	Press Return Operating system assigns drive letters to the devices in this list and in the order displayed. Device order can be changed. Use the up or down arrow to select a device, then press the + or - key to move the device up or down the list.
Summary Screen	Disabled , Enabled When Enabled, shows the system configuration on boot up.

Exit Menu

Choose the Exit Menu by selecting Exit in the legend bar on the Main Menu screen. Other Exit Menu options are available by selecting submenus.

Use the arrow keys to select one of the Exit Menu options and press **Enter** to select a submenu. Explanations of each Exit Menu item are in the following table.

Exit Menu Items

Menu Item	Settings (default is bold)
Exit Saving Changes	Implements the changes just made, and exits BIOS.
Exit Discarding Changes	Exit leaving BIOS unchanged.
Load Setup Defaults	Loads default values for all BIOS setup fields.
Discard Changes	Load previous values from BIOS for all setup fields.
Save Changes	Saves all setup value changes to BIOS.

Hard Drive Security

Your NEC PowerMate 2000 system allows establishing password protection for the internal hard drive. Hard disk drive (HDD) password protection restricts access to the drive *only* if the drive is removed from the PowerMate 2000 system and installed in another system. The system does not prompt you to enter your HDD passwords while the drive remains in the current system.

The HDD passwords are written to the system BIOS and to the hard drive to ensure that the password protection travels with the drive if it is moved to another system.

Establishing Hard Disk Drive Passwords

To establish password protection for the system's hard drive, you must establish a master password, establish a user password, and enable the established passwords for the internal hard drive. Use the following procedure to establish HDD passwords and to enable HDD password protection.



CAUTION If you set the master and user password on a hard drive, you can never remove the passwords. You can change the passwords. If you forget the master password and install the drive in another system, you cannot access the data on the hard drive.

Once you set these passwords, NEC Computers Inc. has no capability of removing them.

If you install the hard drive in another PowerMate system with hard disk drive security enabled, you must enter the password to allow access to the hard drive. **If this PowerMate system does not support hard disk drive security, you cannot access the data on the hard drive.**

1. Boot your system. Press **F2** when prompted to enter BIOS Setup. The Main Menu screen appears.
2. Using the arrow keys, select the Security Menu.
3. Use the down arrow key to highlight **Assign HDD Password** and press **Enter**. The system prompts you to enter a master password.

-
4. Enter a master HDD password and press **Enter**. The system prompts you to reenter the password to verify.
 5. Reenter the master HDD password and press **Enter**. The system confirms the creation of the master password and prompts you to enter a user password.
 6. Enter a user password and press **Enter**. The system prompts you to reenter the password to verify.
 7. Reenter the user password and press **Enter**.
 8. Highlight and select **Primary Master HDD Password**. Use the + (plus) and – (minus) keys to enable the selection. (This enables password protection for the internal HDD.)

Changing Hard Disk Drive Passwords

Use the following procedure to change hard disk drive passwords.

1. Boot your system. Press **F2** when prompted to enter BIOS Setup.
2. At the Main Menu screen, select the Security Menu.
3. Highlight **Assign HDD Password** and press **Enter**.
 - If you enter the current master password, you are prompted to enter a new master password.
 - If you enter the current user password, you are prompted to enter a new user password.
 - If you do not want to establish a new master or user password, press **Esc** instead of entering a new password.
4. Save the changes and exit BIOS Setup.

Using Hard Disk Drive Password Protection

To facilitate the transfer of one or more HDDs between systems, establish a single master password and store the password in a secure place. Forgetting the master password results in the inability to access the data on the hard drive. Establish different user passwords to limit access to specific systems.

 **CAUTION** If you set the master and user password on a hard drive, you can never remove the passwords. You can change the passwords. If you forget the master password and install the drive in another system, you cannot access the data on the hard drive.

Once you set these passwords, NEC Computers Inc. has no capability of removing them.

If you install the hard drive in another PowerMate system with hard disk drive security enabled, you must enter the password to allow access to the hard drive. **If this PowerMate system does not support hard disk drive security, you cannot access the data on the hard drive.**

With hard disk drive security enabled on the original NEC PowerMate 2000 system, the system boots normally.

If you install the hard drive in another NEC PowerMate system with security enabled, you must enter the master password to access the hard drive. If the hard drive is installed in another NEC PowerMate 2000 system with security disabled, the system prompts you to enter the master password and then a new user password.

Moving the Hard Drive

When a password protected hard drive is moved from its original system and installed in another system, error messages appear indicating that the drive is locked. Next, the Security Setup screen appears requiring the user to enter the master password to unlock the drive. Enter the master password, when prompted.

To take advantage of HDD password protection in another system, the system must be equipped with the same HDD password protection feature. To determine if the system has HDD password protection, check the Security Menu in the BIOS Setup to see if there are provisions for establishing HDD passwords.

FLASH Utility

The system BIOS resides on a flash read only memory (ROM) chip in your system. The FLASH ROM can be updated using the following procedure. Before starting the BIOS update, we recommend that you first contact NEC Computers for assistance (see Chapter 6 for contact information).

Update the FLASH ROM with a BIOS FLASH diskette. The diskette contains the latest version of the BIOS code. You can get the diskette from NEC Computers or download the BIOS from the NEC Computers web site. See Chapter 6 for download and web site information.

Update the BIOS from the BIOS FLASH diskette as follows.

1. Write down the BIOS Setup parameters currently set on your system.
2. Turn off the system.
3. Put the FLASH diskette in drive A, and turn on the system.
4. At the flash upgrade menu, choose **Update Flash Memory Area** from a file.
5. When asked for a path/filename, use the arrow keys to select the “.bio” file and press **Enter**.
6. The utility asks for confirmation to load the new flash into memory. Select **Continue with Programming**.
7. After the upgrade completes, remove the diskette.
8. Reboot the system and start the Setup program. Press **F9** to reset the BIOS defaults. Use the recorded Setup selections you made at the beginning of this procedure to set the parameters.

NEC Customize Utility

Use the NEC Customize Utility to install a variety of software applications, drivers, utilities, internet browser, and the NEC INFO Center from the PowerMate Application and Driver CD. Follow these steps to use the NEC Customize Utility.

1. Double click the **NEC Customize** icon on the desktop.

-
2. From the display window, select the desired option.
 3. Click **Launch** to initiate the selection and follow the prompts.

PowerMate Application and Driver CD

The PowerMate Application and Driver CD provides drivers, utilities, NEC INFO Center, internet browser, and a variety of software applications for use with your PowerMate system.

Use these steps to launch the Application and Driver CD.

1. For Windows 2000/Windows NT:
 - Insert the Application and Driver CD into the CD-ROM drive.
 - Double click the **NEC Customize** icon on the desktop.
 - Select **Application and Driver CD**.
 - Click **Install** to launch the CD. The Application and Driver CD dialog box appears.
2. For Windows 98 SE:
 - Insert the Application and Driver CD into the CD-ROM drive.
If the CD does not auto-run, double click the **NEC Customize** icon and highlight **Launch Application and Driver CD**.
 - Click **Install** to launch the CD. The Application and Driver CD dialog box appears.
3. In the Application and Driver CD dialog box, click the selection tab of your choice and click the desired driver, application, or utility.
4. Click **Install** and follow the screen prompts to install your selection.
5. Click **Exit** to close the Application and Driver CD dialog box.
6. Remove the CD from the CD-ROM drive when the installation is complete.

NEC INFO Center

The online NEC INFO Center provides quick access to information about your system. The INFO Center includes the following modules.

- **Tour**
Use Tour to find information about easy-to-use NEC Computers printed and online documentation, software installation tools, and many support services.
- **User's Guide**
Use this module to get quick access to an online version of your printed user's guide.
- **Questions**
Look in this module to get answers to frequently asked questions about your system.
- **Solutions**
Go to this module to find solutions to common system problems.
- **Services**
Check this module for a quick reference to the many NEC Computers support services available to you.

To install the NEC INFO Center from the PowerMate Application and Driver CD, follow the procedures in the previous section, "PowerMate Application and Driver CD." To start the NEC INFO Center, double click the **NEC INFO Center** icon on your desktop. The INFO Center opening screen appears (see the following figure).

Click on an NEC INFO Center module of your choice, depending on the information you want to see. We suggest you start with the Tour module.

NEC INFO Center opening screen



To uninstall the NEC INFO Center, use these steps.

1. At the Windows desktop, click **Start**, point to **Settings**, and click **Control Panel**.
2. At the Control Panel, double click **Add/Remove Programs**.
3. Double click **NEC INFO Center** and follow the prompts.

NEC Product Recovery CD

The NEC Product Recovery CD contains the NEC Product Recovery utility that allows you to restore your system to its initial installation state.

You should only use the Product Recovery CD as a last resort. Check the problem checklist in Chapter 5 for information about solving problems before using the Product Recovery CD. The Product Recovery CD provides options that either remove or replace existing files, a process that may result in data loss.

Carefully review the following Product Recovery CD information before proceeding with a system restore.

 **CAUTION** Choose your restore option carefully to prevent losing data and applications installed on your system. NEC Computers suggests that you contact Technical Support Services for assistance in restoring your hard drive. See Chapter 6, "Getting Service and Support," for information on obtaining NEC Computers support.

Use the Restore System program if you want to restore your hard drive to its factory-installed state. Restore System allows you to restore your system in one of two ways.

- Full Disk Drive — This option completely rebuilds your hard drive, destroying all existing data in the process.
- Partition Only — The Partition Only option lets you preserve your existing hard drive partition structure and format only the primary partition without affecting the extended partition(s).

Note Systems with the Microsoft Windows NT operating system come with the hard drive partitioned as two drives. Systems with the Microsoft Windows 98 SE operating system or the Microsoft Windows 2000 operating system come with the hard drive set as one drive.

Performing Full Disk Restore

If your preinstalled software becomes unusable and you cannot boot from the hard drive, use the Product Recovery CD to restore your system to its initial shipping configuration. The Full Disk restore option *erases* the hard drive *completely* before reinstalling the files.

 **CAUTION** The Full Disk Drive restore option deletes *all* files on the hard drive and replaces them with the original factory-installed files. Only use the Full Disk Drive restore option if the preinstalled software is unusable.

Use the Product Recovery CD to perform a Full Disk Drive restore as follows.

1. Disconnect all peripherals and power on the system.



CAUTION Before using the Product Recovery CD, enter the BIOS Setup utility, record your current settings, and restore the BIOS default settings. Save the default settings before exiting the BIOS Setup utility.

2. Load the PowerMate Product Recovery CD for your operating system into the CD-ROM drive. Reboot the system.
3. Read the License Agreement screen that appears. Click **Accept** to accept the agreement. If you decline, the recovery utility exits.



CAUTION Do not turn off or disturb the system during the following recovery process.

4. At the NEC Product Recovery utility screen, select **Full Disk Drive** to restore your hard disk drive to its original factory installed state.
5. Read the Warning screen.
A warning displays, indicating that your hard disk is about to be erased.
6. Click **Continue** to perform a Full Disk Drive restore.
If you click **Back**, the recovery utility returns to the prior screen, which has an exit option.
If you click **Continue**, a screen with progress bars displays and lets you know the progress of the recovery.
7. When the recovery process is complete, you are prompted to remove the CD from the CD-ROM drive and reboot your system.
8. Press **Enter**, click **Reboot**, or press **Alt-R** to reboot your system.
9. A series of hardware detection screens display, the system reboots, and the Windows Setup screen appears. Follow the screen prompts to set up Windows.

Performing Partition Only Restore

If your system comes with a partitioned hard drive and the factory preinstalled software on drive C: becomes unusable and you cannot boot from the hard disk, use the PowerMate Product Recovery CD to restore the drive C: partition to its initial shipping configuration.

Note Systems with the Microsoft Windows NT operating system come with the hard drive partitioned as two drives. Systems with the Microsoft Windows 98 SE operating system or the Microsoft Windows 2000 operating system come with the hard drive as one drive.

 **CAUTION** Use the Partition Only restore option *only* if your hard drive consists of multiple partitions *and* if drive C: contains the operating system and related drivers. Move all other data and applications from drive C: to other partitions (drives) or the Partition Only restore process will erase them completely.

The Partition Only restore option deletes *all* files on drive C: and replaces them with the original factory installed files. Only use the Partition Only restore option if the preinstalled software on drive C: is unusable.

If you have any question about performing a Partition Only restore, NEC Computers suggests that you contact Technical Support Services before starting the restore procedure. See Chapter 6, "Getting Services and Support," for information on obtaining NEC Computers support.

Use the Product Recovery utility to perform a Partition Only restore as follows.

1. Disconnect all peripherals and power on the system.

 **CAUTION** Before using the Product Recovery CD, enter the BIOS Setup utility, record your current settings, and restore the BIOS default settings. Save the default settings before exiting the BIOS Setup utility.

2. Load the PowerMate Product Recovery CD for your system into the CD-ROM drive. Reboot your system.

-
3. Read the License Agreement screen that appears. Click **Accept** to accept the agreement. If you decline, the recovery utility exits.

 **CAUTION** Do not turn off or disturb the system during the following recovery process.

4. At the NEC Product Recovery utility screen, click **Partition Only** to restore drive C: of a multiple partitioned drive to its original factory installed state.
5. Read the Warning screen.

A warning displays, indicating that drive C: (the primary drive/partition) is about to be erased and formatted. It may be necessary to reinstall software to the other drives (partitions) to reestablish Start Menu links and other configuration requirements stored on drive C:.
6. Click **Continue** to perform a Partition Only restore.

If you click **Back**, the recovery utility returns to the prior screen, which has an exit option.

If you click **Continue**, a screen with progress bars displays and lets you know the progress of the recovery.
7. When the recovery process is complete, you are prompted to remove the CD from the CD-ROM drive and reboot your system.
8. Press **Enter**, click **Reboot**, or press **Alt-R** to reboot your system.
9. A series of hardware detection screens display, the system reboots, and the Windows Setup screen appears. Follow the screen prompts to set up Windows.

System Board Jumper Settings

The system has an easily accessible jumper for clearing your password if you forgot it.

If you need to clear your password, set the jumper as follows.

1. Wake a system in sleep mode, save and close any open applications, close Windows, power down, and unplug the system's AC power adapter and any external options.

⚠ CAUTION To prevent damage to the system board, do not clear your password while power is on.

2. Remove the access panel from the bottom of the system unit (for panel removal, see "Installing a SO-DIMM Module" in Chapter 4).
3. Locate the jumper.

Locating the password clear jumper

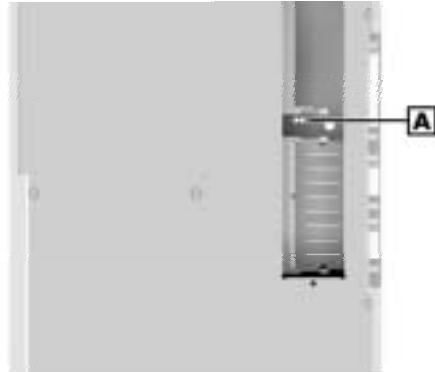

A – Password Clear Jumper

-
4. Remove the jumper from pins 1 and 2 to clear your password.
 5. Place the jumper back on pins 1 and 2.
 6. Replace the access panel, plug in the AC power adapter, and power up the system.
 7. At the startup screen, press **F2** to open the BIOS Setup Utility. Navigate to the Security Menu and set your new password (see “Security Menu” in this chapter for details on setting a password).

Intel Processor Serial Number Control Utility

The Intel Processor Serial Number Control Utility is a Windows program that enables or disables the reading of the Pentium III processor serial number by software. This function lets you control which software programs or web sites have permission to read the processor serial number. When enabled, the utility runs automatically each time the system powers on.

This utility places an icon in the Windows system tray. The icon provides a visual status of the processor serial number. You have the option of hiding the system tray icon. You can enable or disable the processor serial number at any time. However, enabling the serial number requires restarting the system.

The following information describes:

- system requirements
- installation procedures
- processor serial number features
- FAQs
- technical support.

System Requirements

The Intel Processor Serial Number Control Utility requires:

- a Pentium III processor-based system
- Windows 98, Windows NT 4.0 (or later), or Windows 2000
- 2 megabytes of hard drive space.

Installation

The Intel Processor Serial Number Control Utility (version 1.03) comes already installed on the system. The system ships with the processor serial number turned off.

Processor Serial Number

The Intel processor serial number, a feature of the Pentium III processor, is an identifier for the processor. The processor serial number is unique, and when used in conjunction with other identification methods, can be used to identify the system or user. This number can be used in a wide variety of applications which benefit from stronger forms of system and user identification.

The processor serial number is analogous to a conventional serial number, with these important differences:

- A software application can read the processor serial number.
- You can enable or disable the reading of the serial number via utility programs such as this one, or via the BIOS, depending on the system configuration.

For additional information about the Pentium III processor and the processor serial number, visit www.intel.com/pentiumiii.

Frequently Asked Questions

What are the benefits of the processor serial number?

You can use the processor serial number in applications which benefit from stronger forms of system and user identification.

Why would I want to turn off my processor serial number?

Intel believes the processor serial number can provide compelling benefits to users. They are developing features in conjunction with the processor serial number to allow responsible service providers to provide services which maintain your privacy. However, if you are concerned that a given application/service using your processor number might impact your privacy, you can turn off the processor serial number using the utility.

What is the default state of the processor serial number?

The default state of the processor serial number is on, until the Processor Serial Number Control Utility is installed. Once the Processor Serial Number Control Utility is installed, it turns the processor serial number off by default. You can use the utility to turn on the processor serial number.

Can a web site read my serial number without my knowledge?

No, generally not. Web sites cannot read serial numbers unless you allow them to download a program which can read the processor serial number. Almost all browsers are configured to warn users whenever they download executable software. Unless you disable the warning in the browser, you should receive a notification.

Does Intel track serial numbers?

Generally not, other than related to the manufacturing process. Intel does not, in the absence of advance and express consent of a user, collect serial number data which is otherwise identified with a user.

Which programs and/or web sites currently use the processor serial number?

You can find a complete list of programs which can take advantage of the processor serial number and other new capabilities of the Pentium III processor at <http://www.intel.com/pentiumiii/utility.htm>.

How can I tell if my processor serial number is turned on?

The vast majority of Pentium III processor-based systems ship with the processor serial number enabled. The control utility allows you to check the status by:

- Viewing the icon itself. The disabled icon shows a red circle with a white “x.”
- Clicking the task tray icon and selecting the “Status” menu item. Or you can select the menu from the tool tip shown when you position the mouse over the task tray icon.

Technical Support

For world wide 7 days a week, 24 hours a day technical support, please visit the Intel support web site at **<http://support.intel.com>**.

Email: **support@intel.com**.

In the United States, call **800-628-8686** from 5:00 a.m. to 5:00 p.m. Pacific Standard Time.

For world wide phone contacts, please see **<http://support.intel.com/support/feedback.htm>**.

4

Adding Expansion Devices

- Safety Precautions
- USB Devices
- PC Cards
- Memory Modules
- Hard Drive
- Parallel Printer
- External Monitor
- Serial Devices

This chapter provides information for adding a variety of industry-standard expansion devices to your system.

Included in the chapter are procedures for installing:

- USB devices
- PC Cards
- memory modules
- hard drive
- printer
- external monitor
- external serial devices.

Safety Precautions

Observe safety rules when handling system components. Avoid electric shock or personal injury by observing the following warning.

 **WARNING** Before removing the panel on the bottom of the system unit, wake a system in sleep mode, close the Microsoft Windows operating system, turn off system power, and unplug the system AC power adapter. Power is removed only when the AC power adapter is unplugged.

Static electricity and improper installation procedures can damage computer components. Protect computer components by following these safety instructions.

 **CAUTION** Electrostatic discharge can damage system components. Discharge static electricity by touching a metal object before removing the panel on the bottom of the system unit.

- Avoid carpets in cool, dry areas. Leave PC Cards and memory modules in their anti-static packaging until ready to be installed.

-
- Dissipate static electricity before handling any system components (PC Cards, memory modules) by touching a grounded metal object, such as the unpainted bottom plate on the system unit.

If possible, use antistatic devices, such as wrist straps and floor mats.

- Always hold a PC Card or memory module by its edges. Avoid touching the contacts and components on the card or module.
- Take care when connecting or disconnecting cables. A damaged cable can cause a short in the electrical circuit.
- Prevent damage to the connectors by aligning connector pins before you connect the cable.

Misaligned connector pins can cause damage to system components at power-on.

- When disconnecting a cable, always pull on the cable connector or strain-relief loop, not on the cable itself.

USB Devices

The two USB ports on the right side of the system unit allow you to connect up to 127 USB devices. These devices include hard drives, scanners, printers, digital cameras, CD-ROM drives, modems, keyboards, mouse, speakers, telephones, game devices, and more.

USB drivers are constantly being developed and updated for compatibility and improved performance. Be sure to check that you have the latest driver for the USB device you are adding, particularly if you are using the Microsoft Windows 2000 operating system or the Microsoft Windows NT operating system.

You can add multiple USB devices in several ways:

- add two devices, one to each USB port on the right side of the system
- add multiple devices to each port by “daisy-chaining” each device to the next device
- add multiple devices to each port through an optional multiple-port hub(s).

Connecting USB devices is easy. You don't need to turn off the system to connect or disconnect the devices. Simply match the connectors on the USB cable to the USB port on your system and the port on the USB device, then plug in the cable.

For multiple USB devices, plug the USB cable on the new device into a free USB port on the existing device (many devices come with two or more ports).

Most USB devices do not need a separate power source as they draw their power from the system. Some high power devices (for example, USB hubs and amplified speakers) might need their own power supplies.

PC Cards

Your system supports Type II and Type III PC Cards for extending system capabilities. All cards have a standard 68-pin connector.

Type II PC Cards are often storage or communication devices such as Static Random Access Memory (SRAM), Read Only Memory (ROM), Flash Memory, modem, and Small Computer System Interface (SCSI).

Some PC Cards are Type II extended cards. The extended card has an additional physical component that protrudes beyond the normal card size. The extension provides room for additional electronics as well as a location for external connectors.

Type III PC Cards are thicker than Type II PC Cards and allow no extensions. Type III PC Card uses include advanced function cards with additional features such as multimode cards (such as a combined modem and LAN card) and small hard drive storage.

Inserting a PC Card

The system integrates two CardBus slots on the left side of the system unit. Use the slots to insert up to two Type II PC Cards, either 16-bit or 32-bit (CardBus) or one Type III PC Card. The Type II PC Cards can be inserted in either or both slots. The Type III PC Card goes in the bottom slot only, with no card in the top slot. The CardBus slots do not support zoomed video (ZV Port).

To insert a PC Card, follow these steps.

1. Remove the PC Card slot cover by pressing the eject button next to the slot. Pull the cover out of the slot and save it.
2. Align the PC Card so that the connector end points toward the PC Card slot and that the printed label side is up.

Inserting a PC Card



A – PC Card
B – PC Card Slot

C – PC Card Eject Button

3. Insert a Type II PC Card into either slot or a Type III PC Card in the bottom slot.

A low tone followed by a high tone lets you know that the card is fully inserted and recognized.

Other tone sequences such as high, then low tones, indicate that the card is inserted but not recognized (card type unknown).

-
4. Use the software installed on your system to check PC Card slot availability.

In the Microsoft Windows 98 SE or Microsoft Windows 2000 operating system, a PC Card icon should be in the control panel or on the right side of the task bar. The icon shows which slot contains a PC Card and which slot is empty.

In the Microsoft Windows NT operating system, the CardWizard™ SystemsSoft icon should be on the desktop.

5. Follow the PC Card manufacturer's instructions for using the card.

Removing a PC Card

Follow these steps to remove a PC Card from its slot in the system unit.

1. At the Windows desktop, point to **My Computer** and to **Control Panel** (or select the taskbar PC Card icon).
2. Select the PC Card you need to remove and select **Stop**.

Windows alerts you if any applications are still using the card. Close the application(s).

If all applications using the PC Card are shut down, services for that card are closed.

A message displays on the screen stating that it is safe to remove the PC Card.

3. Remove the PC Card from its slot by pressing the eject button next to the slot. Pull the card out.
4. If you are not installing another PC Card, insert the previously removed slot cover into the slot to keep dust and dirt out.

Memory Modules

Memory modules are installed into one or two SO-DIMM sockets on the system board. The sockets are accessible from the bottom of the system unit.

The sockets support up to 512 MB of high-speed memory. The system supports 144-pin PC100 SDRAM modules in 64-MB, 128-MB, and 256-MB non-ECC memory configurations.

Use the following guidelines in selecting SO-DIMM types:

- Memory can be installed in one or two sockets.
- The size of the SO-DIMMs can vary between sockets.
- Single- and double-sided SO-DIMMs are supported.

For sample memory configurations, see the table “Sample SO-DIMM Upgrade Paths.”

To determine the memory you need to purchase for a memory upgrade, see “Checking System Memory.”

Sample SO-DIMM Upgrade Paths

Total System Memory	SO-DIMM 0	SO-DIMM 1
128 MB	64 MB	64 MB
128 MB	128 MB	--
192 MB	128 MB	64 MB
256 MB	128 MB	128 MB
512 MB	256 MB	256 MB

The modules use 100 MHz synchronous dynamic random access memory (SDRAM). Memory allocation is controlled by DVMT. With DVMT, total system memory is shared between system memory and video memory.

For example, with 128 MB of total system memory, 112 MB might be allocated for system memory and 16 MB for video memory, with actual memory usage dependent on video usage.

Checking System Memory

If you do not know how much memory is installed in your system, check the amount by using the following procedure.

1. On the Microsoft Windows 98, Windows 2000, or Windows NT 4.0 desktop, point to **My Computer** and click the right mouse button.
2. With the left mouse button, click **Properties**. The **General** tab shows the random access memory (RAM). This is the amount of system memory in the computer.

In the Microsoft Windows 98 or Windows 2000 operating system, you can also find the amount of memory by pointing to **My Computer**, clicking the right mouse button, and selecting the **Performance** tab.

Installing a SO-DIMM Module

Use the following steps to install a SO-DIMM memory module.



CAUTION To prevent damage to system components and the memory modules, wake a system in sleep mode, exit Windows, power down the system, and unplug the AC power adapter power cord from the power source.

1. If your system is in sleep mode, move the mouse or press a key to take it out of sleep mode.
2. Save and exit all your open applications and shut down Windows.
3. Shut down the system by pressing and holding in the power button for four seconds or more.
4. Unplug the AC adapter power cord from the power source.
5. Swivel the LCD panel to the right and position the unit on its side, as shown in the following figures.

Positioning the LCD panel



⚠ CAUTION To prevent damage to the LCD panel, be sure to position the unit with the LCD panel facing up.

Positioning the system for memory upgrade

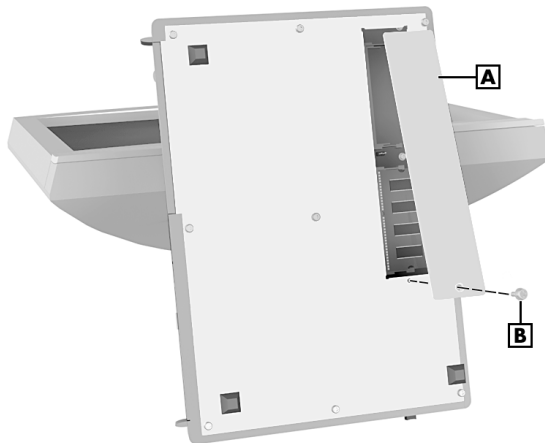

A – Memory Module Panel **B** – Screw

6. Remove the screw securing the memory module panel and remove the panel.

-
7. Locate an empty module slot. If you need to remove one or both modules, see “Removing a SO-DIMM Module” in the next section.

⚠ CAUTION Before you install a SO-DIMM, reduce static discharge by touching a metal part on the system unit.

8. Install the SO-DIMM module as follows (see the following figure).
 - Align the notch in the module with the key in the empty slot.
 - Hold the module at a 45-degree angle and insert it into the slot.
 - Firmly push the module into the socket.
 - Press down on the edge of the module until the plastic retaining clips snap into place.

Installing the SO-DIMM module

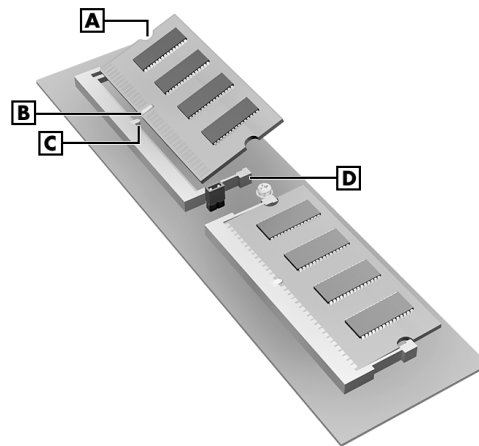

A – SO-DIMM Module C – Socket Key
B – Notch D – Plastic Retaining Clip (2)

9. Install the SO-DIMM module panel and retaining screw.
10. Plug in the AC adapter power cord and press the power switch.

Removing a SO-DIMM Module

If you need to remove a SO-DIMM module, use the following steps.

 **CAUTION** To prevent damage to system components and the memory modules, wake a system in sleep mode, exit Windows, power down the system, and unplug the AC adapter power cord from the power source.

1. If your system is in sleep mode, move the mouse or press a key to take it out of sleep mode.
2. Save and exit all your open applications and shut down Windows.
3. Shut down the system by pressing and holding in the power button for four seconds or more.
4. Unplug the AC adapter power cord from the power source.

 **CAUTION** To prevent damage to the LCD panel, position the system as shown in the figure “Positioning the system for memory upgrade” in the previous section.

5. On the bottom of the system unit, remove the screw fastening the module panel to the unit. Remove the panel (see the figure “Positioning the system for memory upgrade” in the previous section).
6. Locate the module that you want to remove.
7. Eject the module by pressing the plastic retaining clips at the outer edges of the socket away from the memory module.
8. If you are installing a module, see “Installing a SO-DIMM Module.”
9. Install the SO-DIMM module panel and retaining screw.
10. Plug in the AC adapter power cord and press the power switch on the system unit.

Hard Drive

You can upgrade or replace your hard drive without removing the system unit cover. The hard drive is located on the right side of the system unit, under the hard drive access panel.

To upgrade or replace the hard drive, you must first remove the installed drive (see “Removing a Hard Drive,” next). To install a replacement hard drive, see “Installing a Hard Drive” later in this chapter.

Removing a Hard Drive

Use the following steps to remove the installed hard drive.

 **CAUTION** To prevent damage to system components, wake a system in sleep mode, exit Windows, power down the system, and unplug the AC power adapter power cord from the power source.

1. If your system is in sleep mode, move the mouse or press a key to take it out of sleep mode.
2. Save and exit all your open applications and shut down Windows.
3. Shut down the system by pressing and holding in the power button for four seconds or more.
4. Unplug the AC adapter power cord from the power source.
5. Turn your system unit so that the right side and the hard drive access panel faces you. Carefully swivel the LCD panel out of the way.
6. Release the access panel by pressing down on the two latches on top of the panel (see the following figure for latch location). Set the panel aside.

Releasing the hard drive access panel



A – Latches **B** – Hard Drive Access Panel

7. Grasp each end of the interface cable connector (*not* the cable) and carefully unplug the cable connector from the hard drive. The connector seats tightly on the hard drive and requires a firm pull.

⚠ CAUTION To prevent damage to the hard drive interface cable when unplugging it, pull on the cable connector, not the cable.

Use care when removing the drive to avoid damage to the interface cable.

8. Grasp the plastic tab attached to the hard drive and carefully pull the drive out of the drive bay. The drive seats tightly in the bay and requires a firm pull. Set the drive aside.

⚠ CAUTION Hold the hard drive by its sides, not the top and bottom. Holding it by the top and bottom might inadvertently squeeze the drive and cause drive failure.

Installing a Hard Drive

Install a hard drive as follows.

1. Remove the installed hard drive (see “Removing a Hard Drive” earlier in this chapter).
2. Check that the interface cable is out of the way and not behind the system cover.

 **CAUTION** To prevent damage to the pins on the hard drive connector when seating the drive, press in on the sides of the connector and not on the pin area.

3. Align the drive, tab side up, in front of the bay and start it into the bay. Firmly press in on the *sides* of the drive (not the pins) until the drive is fully seated in the bay.

 **CAUTION** To prevent damage to the pins on the hard drive connector when connecting the interface cable, carefully align the cable connector with the two rows of pins on the left side of the hard drive connector. Do not plug into the four pins on the right side of the drive connector.

4. Align the interface cable connector with the pins on the drive connector and carefully plug in the connector. Use care to avoid positioning the connector over the four pins on the right side of the connector.
5. Push the hard drive plastic tab inside the system unit cover.
6. Install the tabs on the bottom of the access panel into the corresponding slots on the system unit. Press the panel in until it snaps in place.
7. Plug in the AC adapter power cord and press the power switch.

Parallel Printer

You can connect a standard parallel printer to the system unit. To install the printer, you need the printer drivers and a printer cable. Use a cable with a male 25-pin connector for connecting to the parallel port on the back of the system unit and a Centronics[®]-compatible 36-pin connector on the other end for connecting to the printer.

Refer to the printer documentation for details on installing the printer, including driver installation and cabling instructions.

External Monitor

You can add a standard Plug and Play external monitor to the system unit. The VGA connector on the back of the system unit supports any size NEC MultiSync[®] monitor, NEC AccuSync[™] monitor, or other VGA-compatible monitor with a 15-pin connector.

To install the monitor, you need a power cable and a signal cable (both are usually supplied with the unit). The signal cable must have a 15-pin cable connector for connecting to the system unit.

Power down the system and connect the signal cable to the VGA port on the back of the system unit and the power cable to a grounded wall outlet.

Turn on the monitor and power up the system unit. On power up, the LCD panel automatically turns on. With this feature, you can view your applications with the LCD panel and monitor at the same time.

See the monitor documentation for details on installing, setting up, and adjusting the unit.

Serial Devices

You can add external Plug and Play serial devices such as an external modem or a printer to the system unit. Connect the device to the serial port on the back of the system unit. To install the device, you need the device drivers and a serial cable with a female 9-pin connector.

Power down the system unit. Connect the device cable to the serial port on the back of the system unit and connect the power cable to a grounded wall outlet. See your device documentation for further details on installing and setting up the serial device.

5

Solving System Problems

- Solutions to Common Problems
- How to Clean the Mouse

You may occasionally encounter a problem with the system. In most cases, the problem is one that you can solve yourself.

The system has a built-in program that automatically checks its components when the system is powered on. If there is a problem, the system displays an error message. If this happens, follow any instructions on the screen.

If screen messages do not help or an error message does not appear, refer to the information in this chapter to help determine and solve the problem.

Solutions to Common Problems

See the following sections to match your problem area and view the possible causes and solutions.

When trying to solve problems, you should note what the system was doing when the problem occurred and what you attempted to do to correct the problem. This information is useful if you request assistance.

System Problems

Check the following list to match your problem and see the possible cause and solution.

- **No power and power lamp not lit.**

Check that system power is on.

Check that the AC adapter and power cord are connected together.

Check that the AC adapter power cord is plugged into the system DC power socket on the system unit and into a live, properly grounded AC power outlet or surge protector.

Check the outlet or surge protector by plugging in a lamp.

- **Non-System Disk error message displays when the system is started.**

You have a diskette in the diskette drive, and the diskette drive is set before the hard drive in boot order. Remove the diskette from drive A and restart the system.

- **Operating system not found error message displays when the system is started.**

If you left a CD in the CD-ROM drive, your system might not be able to boot. Try removing the CD and rebooting.

- **System does not boot and error message displayed on screen.**

Run the BIOS Setup Utility (see Chapter 3). Check that the parameters are set correctly, particularly if you just installed an option.

- **System emits continuous beeps.**

Turn the system off, wait at least five seconds, and turn the system on. If the beeps continue, call the NEC Computers Technical Support Center.

- **System does not maintain date, time, system configuration information.**

Have the CMOS battery checked and replaced by an NEC Computers authorized service center. The battery is not user replaceable.

- **System does not boot from hard drive.**

The system usually tries to start from the diskette drive before it starts from the hard drive. Remove the diskette from the diskette drive.

Run the Setup Utility (see Chapter 3) and set the initial Boot parameter to a hard disk device instead of floppy disk device.

- **System performance appears sluggish.**

You might have too many applications open. Close any applications that you are not using.

Check your Internet browser and Microsoft Windows operating system for excessive Internet cache files. Delete the cache files as necessary (see the browser and Microsoft Windows online documentation for further information).

Check the memory requirements of your software applications. If required, install additional SO-DIMM memory (see Chapter 4).

If you added optional memory, check that you correctly installed the SO-DIMM memory.

- **System shuts off instead of going into sleep mode.**

You pressed and held in the power/sleep button for more than four seconds. For sleep mode, press in the button and immediately release.

- **System does not shut off after pressing the power/sleep button.**

You might not have pressed and held in the power/sleep button long enough. Press in the button and hold for four seconds or more before releasing.

- **System password forgotten.**

Clear the password and reset it. To clear the password, see “System Board Jumper Settings” in Chapter 3. To reset the password, see “Security Menu” in Chapter 3.

Diskette Drive Problems

Check the following problems to see the possible cause and solution.

- **Diskette won't load.**

Check that a diskette is not in the drive.

Check that the diskette is being loaded correctly.

Check that the system power lamp is on and that the power-on screen appears.

Check that the diskette is formatted. If not, format it. See your operating system documentation.

Check that the diskette size is 1.44 MB.

If the diskette drive busy lamp does not light when you load the diskette, try a different diskette. If this loads, the problem is in the software.

- **Non-System Disk or Disk Error message displayed.**

If you are trying to boot from the diskette drive, insert a diskette with system files into drive A.

If a bootable diskette does not boot, use the BIOS Setup Utility to verify that the initial boot parameter is set to diskette drive A and not a hard drive.

LCD Panel Problems

Check the following problems to see the possible cause and solution.

- **Screen is dark or the display is hard to read.**

Adjust the LCD panel brightness control setting. (Note that the brightness setting returns to the system default setting on power down.)

Press a key or move the mouse to take the system out of the power management mode.

Check that the system AC adapter power cable is connected to a live power outlet.

- **The screen display is fuzzy or flickering; graphics characters or garbage appears on the screen.**

Check that all connections have been made.

Check display properties. Click the right mouse button anywhere on the Windows desktop and a menu appears. Click **Properties** and the Display Properties window appears.

Keyboard/Mouse Problems

Check the following problem to see the possible cause and solution.

- **Mouse or keyboard does not respond.**

You might have connected the mouse and keyboard after turning on your system. Turn the system off, make sure the mouse and keyboard are connected, and turn the system back on.

Using the mouse results in erratic or no movement of the cursor on the monitor screen, even after cleaning. Mouse might need to be replaced.

- **Image appears on screen but nothing happens when you use the mouse or keyboard.**

Make sure the keyboard cable and mouse cable are firmly connected to the rear of the system.

If this does not help, turn off the system, wait five or more seconds, and turn on the system.

CD-ROM Drive Problems

Check the following problems to see the possible cause and solution.

- **The system does not see the drive.**

The drive designation is wrong and should be changed. The drive designation depends upon the storage device configuration in your system. To find out what drive designation letter is assigned to your drive, double click **My Computer** on the Microsoft Windows 98, Windows 2000, or Windows NT 4.0 desktop. The drive designation is below the drive icon.

You can also open Windows Explorer and scroll down the list of folders until you locate the drive icon. The drive designation is beside the icon.

- **The drive is not reading a disc.**

Check that the disc is inserted in the disc tray with the printed label side up.

Check that the disc is a data disc, not a music disc.

Clean the non-label side of the disc with a soft lint-free cloth, gently brushing from the center of the disc to the outer edge of the disc. Or use a commercial CD disc cleaner.

Try a different disc to see if the problem is limited to one disc.

- **The disc does not eject due to a power failure or software error.**

Turn off the system and use the emergency eject feature. Insert the end of a paper clip into the eject hole on the front of the system unit (see the figure "System unit front features" in Chapter 1 for location of the eject hole). Press inward on the clip to open the door.

- **The drive plays music CDs but the sound is not heard.**

Adjust the volume control on the side of the system unit. Check the volume control in the system tray along the taskbar.

Speaker Problems

Check the following problems to see the possible cause and solution.

- **Speaker volume is too low.**

Adjust the volume control on the side of the system unit. If the volume is still too low, adjust the volume through the system software. See your Microsoft Windows Multimedia online help.

- **No sound.**

If using a headset, check that it is plugged in.

- **Sound is only coming from one speaker.**

Balance the speaker output by adjusting the balance in the sound software. See your Microsoft Windows Multimedia online help.

How to Clean the Mouse

Under normal conditions, your mouse has a self-cleaning mechanism that prevents a buildup of dust or lint around the mouse ball and tracking mechanism. Periodically, however, you might need to clean the mouse ball.

Use these steps to clean your mouse.

1. Wake a system in sleep mode, save and close any open applications, close the operating system, and power off your system and any peripherals attached to it.
2. Turn the mouse over. Locate the mouse ball cover (see the following figure).

Typical mouse ball cover



A – Mouse Ball Cover

3. Rotate the ball cover counterclockwise and remove the cover.
4. Turn the mouse over so that the cover and ball fall into your palm.
5. Clean the mouse as follows.
 - Use tap water, or tap water and a mild detergent, to clean the mouse ball.
 - Use a clean, lint-free cloth to dry the ball.
 - Blow into the mouse ball socket to remove remaining dust or lint. Use a Q-tip to remove accumulations of dirt.
6. Gently put the ball back into the mouse ball socket.
7. Fit the ball cover into the mouse and turn the cover clockwise until it locks in place.

6

Getting Services and Support

- NEC Computers Web Site
- NEC Computers FTP Site
- Email/Fax Technical Support Services
- NEC Computers Technical Support Services

If you tried correcting problems yourself or within your company and were not successful, you may want to try one or more of the following NEC Computers 24-hour services for answers to your questions. (Some services require a connection to the Internet or a fax machine.)

- NEC Computers web site and FTP site
- Email to NEC Computers Technical Support Services through a commercial online service or the Internet
- Fax Service to NEC Computers Technical Support Services
- NEC Computers Technical Support Services

This chapter describes these services and how to access them.

NEC Computers Web Site

If you have access to the Internet (via your network or optional modem), you can access the NEC Computers web site. You can do this through a commercial online service or through your Internet account. The NEC Computers web site contains general information about NEC Computers and its products. The web site also contains press releases, reviews, and service and support information.

Look in the Service and Support area for the following information:

- technical documentation, including Frequently Asked Questions, user's guides, reference manuals, and warranty information
- BIOS updates, drivers, and setup disk files to download
- contact information, including telephone numbers for Technical Support and links to vendor web sites
- automated email form for your technical support questions
- Reseller's area (password accessible).

To access the NEC Computers Home Page, enter the following Internet Uniform Resource Locator (URL) in your browser:

`www.neccomp.com`

NEC Computers FTP Site

You can use the Internet to access the NEC Computers FTP (file transfer protocol) site to download various files (video drivers, printer drivers, BIOS updates, and Setup Disk files). The files are essentially the same files as on the NEC Computers web site.

To access the NEC Computers FTP site, enter the following Internet ftp address through your service:

ftp://ftp.neccsdeast.com/pub/

Once in the file menu, select the file(s) you want and follow the prompts to download them.

Email/Fax Technical Support Service

The NEC Computers Technical Support Center offers technical support by Internet email if you have access. The Internet email address is:

tech-support@nec-computers.com

You can also fax technical questions to the Technical Support Center if you have fax capabilities. The fax number is:

801-579-1552

When using the email or fax support service, please include the following appropriate word in the subject field for prompt response from the appropriate technical person:

- Desktop
- Monitor.

You should provide as much specific information about your questions as possible. Also, if you are sending a fax, please include your voice telephone number and your fax number with the question. You should receive a response to your questions within one business day.

NEC Computers Technical Support Services

NEC Computers also offers direct technical support through its Technical Support Center. (Technical support is for U.S. and Canadian customers only; international customers should check with their sales provider.)

Direct assistance is available 24 hours a day, 7 days a week. Call the NEC Computers Technical Support Center, toll free, at **800-632-4525** (U.S. and Canada only) for the following support.

- System hardware — toll-free phone support is limited to the length of the standard warranty.
- Preinstalled software — toll-free phone support for 90 days from the time of your first call to the Technical Support Center.

Please have available your system's name, model number, serial number, and as much information as possible about your system's problem before calling.

For outside the U.S. and Canada, please contact your local NEC Computers sales provider.

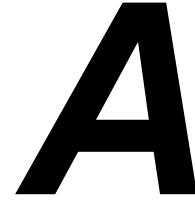

Setting Up a Healthy Work Environment

- Making Your Computer Work for You
- Arrange Your Equipment
- Adjust Your Chair
- Adjust Your Input Devices
- Adjust Your Monitor
- Vary Your Workday
- Pre-existing Conditions and Psychosocial Factors
- Checking Your Comfort: How Do You Measure Up?

! WARNING Prolonged or improper use of a computer workstation may pose a risk of serious injury. To reduce your risk of injury, set up and use your computer in the manner described in this appendix.

Contact a doctor if you experience pain, tenderness, swelling, burning, cramping, stiffness, throbbing, weakness, soreness, tingling and/or numbness in the hands, wrists, arms, shoulders, neck, back, and/or legs.

Making Your Computer Work for You

Computers are everywhere. More and more people sit at computers for longer periods of time. This appendix explains how to set up your computer to fit your physical needs. This information is based on ergonomics — the science of making the workplace fit the needs of the worker.

Some nerve, tendon, and muscle disorders (musculoskeletal disorders) may be associated with repetitive activities, improper work environments, and incorrect work habits. Examples of musculoskeletal disorders that may be associated with certain forms of repetitive activities include: carpal tunnel syndrome, tendinitis, tenosynovitis, de Quervain’s tenosynovitis, and trigger finger, as well as other nerve, tendon, and muscle disorders.

Although some studies have shown an association between increasing hours of keyboard use and the development of some musculoskeletal disorders, it is still unclear whether working at a computer causes such disorders. Some doctors believe that using the keyboard and mouse may aggravate existing musculoskeletal disorders.

Some people are more susceptible to developing these disorders due to preexisting conditions or psychosocial factors (see “Preexisting Conditions and Psychosocial Factors” later in the appendix).

To reduce your risk of developing these disorders, follow the instructions in this appendix. If you experience discomfort while working at your computer or afterwards, even at night, contact a doctor as soon as possible. Signs of discomfort might include pain, tenderness, swelling, burning, cramping, stiffness, throbbing, weakness, soreness, tingling and/or numbness in the hands, wrists, arms, shoulders, neck, back, and/or legs.

Arrange Your Equipment

Arrange your equipment so that you can work in a natural and relaxed position. Place items that you use frequently within easy reach. Adjust your workstation setup to the proper height (as described in this appendix) by lowering the table or stand that holds your computer equipment or raising the seat height of your chair. To create more desk space, you can put your computer base on the floor.

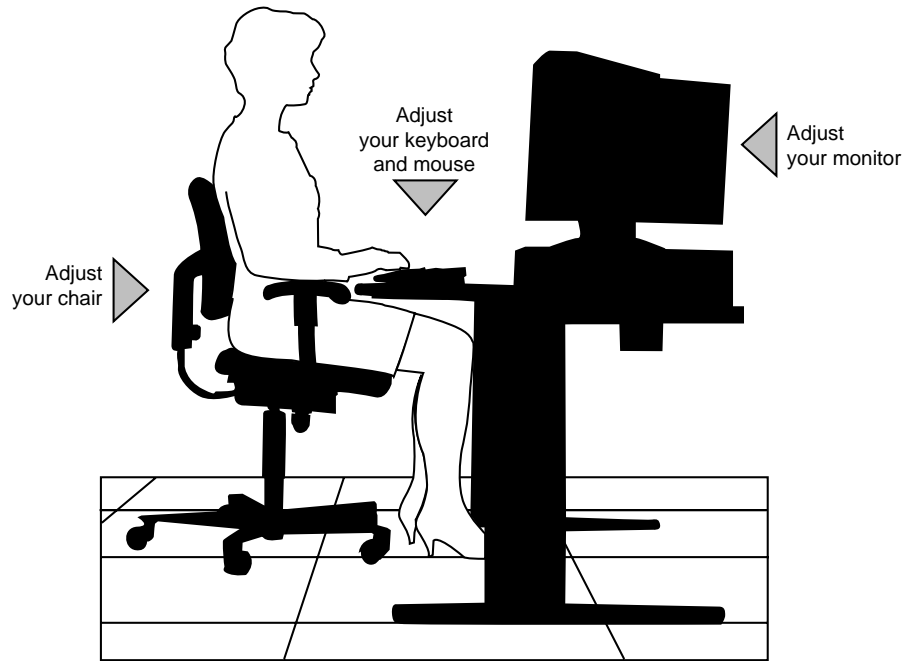

Adjust Your Chair

Your chair should be adjustable and stable. Vary your posture throughout the day.



Check the following:

- Keep your body in a relaxed yet upright position. The backrest of your chair should support the inward curve of your back.
- Use the entire seat and backrest to support your body. Tilt the backrest slightly backwards. The angle formed by your thighs and back should be 90° or more.
- Your seat depth should allow your lower back to comfortably contact the backrest. Make sure that the backs of your lower legs do not press against the front of the chair.

-
- Extend your lower legs slightly so that the angle between your thighs and lower legs is 90° or more.
 - Place your feet flat on the floor. Only use a footrest when attempts to adjust your chair and workstation fail to keep your feet flat.
 - Be sure that you have adequate clearance between the top of your thighs and the underside of your workstation.
 - Use armrests or forearm supports to support your forearms. If adjustable, the armrests or forearm supports should initially be lowered while all the other adjustments discussed in this appendix are made. Once all these adjustments are completed, raise the armrests or adjust the forearm supports until they touch the forearms and allow the shoulder muscles to relax.

Adjust Your Input Devices

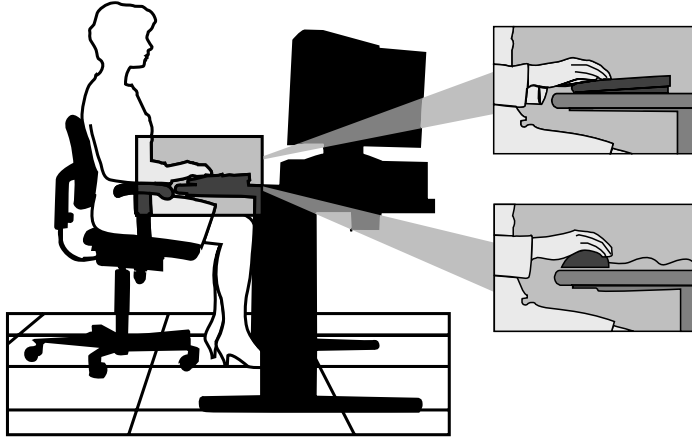

Follow these points in positioning your keyboard and mouse.

- Position your keyboard directly in front of you. Avoid reaching when using your keyboard or mouse.
- If you use a mouse, position it at the same height as the keyboard and next to the keyboard. Keep your wrists straight and use your entire arm when moving a mouse. Do not grasp the mouse tightly. Grasp the mouse lightly and loosely.
- Adjust the keyboard height so that your elbows are near your body and your forearms are parallel to the floor, with your forearms resting on either armrests or forearm supports, in the manner described previously. If you do not have armrests or forearm supports, your upper arms should hang comfortably at your sides.
- Adjust your keyboard slope so that your wrists are straight while you are typing.

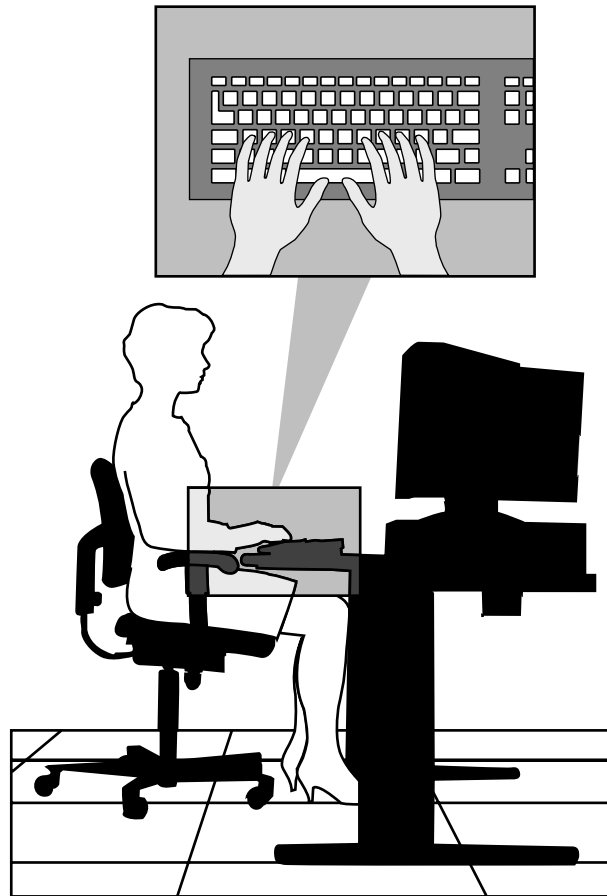

- Type with your hands and wrists floating above the keyboard. Use a wrist pad only to rest your wrists between typing. Avoid resting your wrists on sharp edges.
- Type with your wrists straight. Instead of twisting your wrists sideways to press hard-to-reach keys, move your whole arm. Keep from bending your wrists, hands, or fingers sideways.
- Press the keys gently; do not bang them. Keep your shoulders, arms, hands, and fingers relaxed.

Adjust Your Monitor

Correct placement and adjustment of the monitor can reduce eye, shoulder, and neck fatigue. Check the following when you position the monitor.

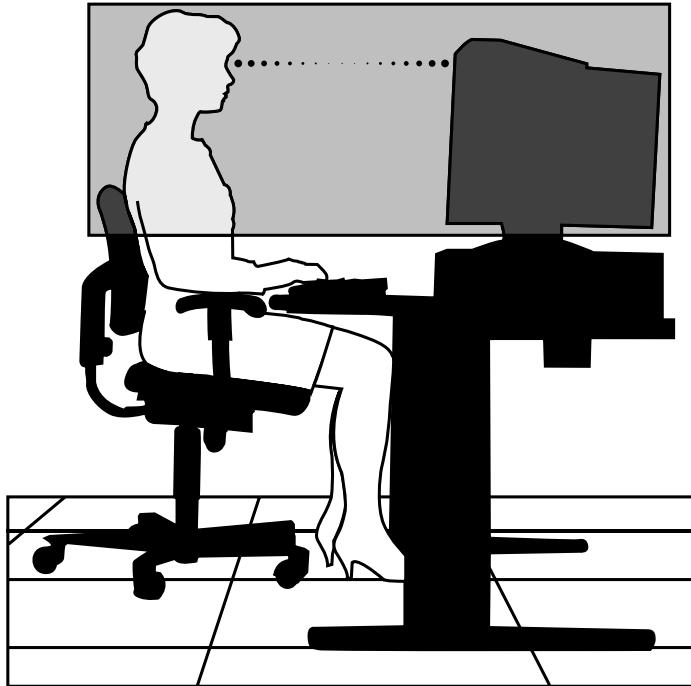

- Adjust the monitor height so that the top of the screen is at or slightly below eye level. Your eyes should look slightly downward when viewing the middle of the screen.
- Position your monitor no closer than 12 inches and no farther away than 28 inches from your eyes. The optimal distance is between 14 and 18 inches.
- Rest your eyes periodically by focusing on an object at least 20 feet away. Blink often.

-
- Position the monitor at a 90° angle to windows and other light sources to minimize glare and reflections. Adjust the monitor tilt so that ceiling lights do not reflect on your screen.
 - If reflected light makes it hard for you to see your screen, use an anti-glare filter.
 - Clean your monitor regularly. Use a lint-free, non-abrasive cloth and a non-alcohol, neutral, non-abrasive cleaning solution or glass cleaner to minimize dust.
 - Adjust the monitor's brightness and contrast controls to enhance readability.
 - Use a document holder placed close to the screen.
 - Position whatever you are looking at most of the time (the screen or reference material) directly in front of you to minimize turning your head while you are typing.
 - Get regular eye check-ups.

Vary Your Workday

If you use your computer for prolonged periods, follow these instructions.

- Vary your tasks throughout the day.
- Take frequent short breaks that involve walking, standing, and stretching. During these breaks, stretch muscles and joints that were in one position for an extended period of time. Relax muscles and joints that were active.
- Use a timer or reminder software to remind you to take breaks.

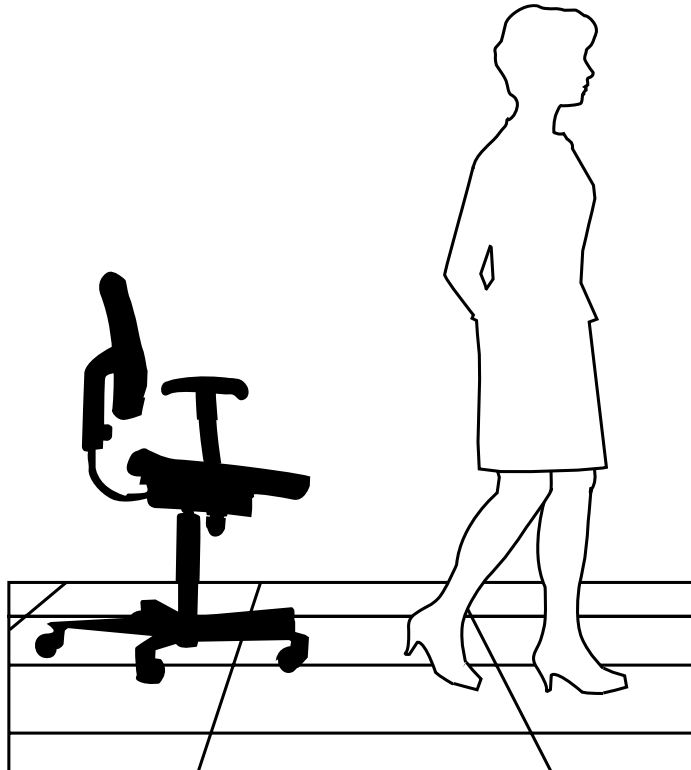

- To enhance blood circulation, alter your sitting posture periodically and keep your hands and wrists warm.

Note For more information on workstation setup, see the American National Standard for Human Factors Engineering of Visual Display Terminal Workstations. ANSI/HFS Standard No. 100-1988. The Human Factors Society, Inc., P.O. Box 1369, Santa Monica, California 90406.

Pre-existing Conditions and Psychosocial Factors

Pre-existing conditions that may cause or make some people more susceptible to musculoskeletal disorders include the following: hereditary factors, vascular disorders, obesity, nutritional deficiencies (e.g., Vitamin B deficiency), endocrine disorders (e.g., diabetes), hormonal imbalances, connective tissue disorders (e.g., arthritis), prior trauma (to the hands, wrists, arms, shoulders, neck, back, or legs), prior musculoskeletal disorders, aging, fluid retention due to pregnancy, poor physical conditioning and dietary habits, and other conditions.

Psychosocial factors associated with these disorders include: workplace stress, poor job satisfaction, lack of support by management, and/or lack of control over one's work.

Contact a doctor if you experience pain, tenderness, swelling, burning, cramping, stiffness, throbbing, weakness, soreness, tingling and/or numbness in the hands, wrists, arms, shoulders, neck, back, and/or legs.

Checking Your Comfort: How Do You Measure Up?

Use this checklist to see if you are setting up your work environment to fit your physical needs.

Checking Your Chair

- Do you sit in an upright position with the backrest supporting your lower back?
- When sitting, are your feet flat on the floor?
- Do you periodically adjust your chair and your posture?

Checking Your Keyboard

- Is your keyboard angled so your wrists are straight when you type?
- Is your keyboard directly in front of you?
- Do you avoid resting your wrists on sharp edges?
- Do you press the keys gently and not bang on them?

Checking Your Mouse

- Is your mouse at the same height as the keyboard and next to the keyboard?
- Are your wrists straight and your touch light when moving the mouse?

Checking Your Monitor

- Did you adjust your monitor so that the top of the screen is at or slightly below eye level?
- Do you periodically rest your eyes by blinking often or looking away from the screen?
- Is your monitor no closer than 12 inches and no farther away than 28 inches from your eyes?
- Do you use a document holder placed close to the screen?

Checking You

- Is your work area set up to promote a natural and relaxing working position with frequently used work items within close reach?
- Do you take frequent short breaks?
- Do you stretch and walk during your breaks?
- Do you vary your tasks during the day?
- Do you have regular eye checkups?
- Do you contact your doctor if you feel any sustained discomfort?

For more information on workstation setup, see the American National Standard for Human Factors Engineering of Visual Display Terminal Workstations. ANSI/HFS Standard No. 100-1988. The Human Factors Society, Inc., P.O. Box 1369, Santa Monica, California 90406

This appendix was prepared in consultation with Dr. David Rempel of the University of California/San Francisco Ergonomics Program and Mr. M.F. Schneider of HUMANTECH, Inc., Ann Arbor, Michigan.

B

System Specifications

- System Board
- System Peripherals
- Dimensions
- Power
- Operating Environment
- Compliance

System Board

The following sections give the specifications for major components on the system board.

System Processor

- Intel Pentium III 933-MHz or higher processor, 133-MHz or higher FSB
- Support — 32-bit addressing, 64-bit data
- Primary cache — 32 KB integrated on processor
- Secondary cache — 256 KB integrated on processor
- Socket — 370-pin Socket 370

Random Access Memory (RAM)

Total system RAM — minimum of 128 MB of SDRAM installed in one of two industry-standard SO-DIMM sockets on system board.

- Total system memory — support for up to 512 MB of high-speed SDRAM in two memory module sockets on system board
- Memory module type — gold-plated, non-parity, SDRAM modules
- Expansion — supports 64-MB, 128-MB, and 256-MB non-ECC 100-MHz SO-DIMM modules

Cache Memory

- pipelined 32-bit addressing
- 64-bit data

Read Only Memory (ROM)

FLASH ROM — 4 Mbit

Calendar Clock

Year/month/day/hour/minute/second/.01 second; maintained by battery

Battery type — Lithium coin cell

Input/Output (I/O) Features

Industry-standard interfaces integrated on system board:

- Universal Serial Bus (USB) — two USB ports support two USB peripherals directly to the system. With appropriate connector, the system supports up to 127 daisy-chained devices. Supports 12 megabits (Mbs) per second.
- Parallel — bi-directional, ECP/EPP support; one 25-pin connector
- Serial — one high-speed RS-232C port using a 16550 UART, supports transfer rates up to 115.2 KB per second; one 9-pin connector
- Keyboard — PS/2[®]-compatible, 6-pin connector (mini DIN)
- Mouse — PS/2-compatible, 6-pin connector (mini DIN)
- Microphone-In — supports a microphone or other audio input device for recording audio information in data files or broadcasting audio
- Line-In — supports input from an external audio device
- Headphone — supports external headphone set
- IDE
 - support for Ultra DMA/66 IDE hard drive and a CD-ROM drive or an optional combination CD-RW and DVD-ROM drive
 - support for PIO mode 3 and mode 4
- Diskette drive — supports 1.44-MB diskette drive; 34-pin connector
- PCMCIA CardBus support for two PC Card slots (Type II and Type III PC Cards)
- RJ-45 LAN connector.

Video Memory

Standard video memory — shared with system memory. Memory allocation controlled by Dynamic Video Memory Technology (DVMT).

Sound Controller

All systems come with audio integrated on the system board. The audio is based on the Intel 82801 (ICH) chip and Analog Devices AD1881A chipset. Features include:

- Compatible with Sound Blaster Pro™, Sound Blaster™ 2.0, MPU-401, and Microsoft® Windows® Sound System™ for PC sound applications
- 16-bit stereo full-duplex codec
- AC'97 SoundMAX® codec audio controller
- Stereo jacks — microphone-in and line-out
- Full duplex variable 8 kHz to 48 kHz sampling rate with 1 Hz resolution.

Network Board

The system comes with an Accton EN2242A-3 Mini PCI network board installed on the system board. Features include:

- Realtek RTL8139CL chipset
- PCI bus master data transfer
- 10Base-T/100Base-TX.

Modem Board

Some systems might come with an optional Mini PCI modem board installed on the system board. Features include:

- V.90 56 kbps data transfer
- Resume on ring
- V.17 14.4 kbps FAX.

Graphics Controller

Systems come with the AGP graphics controller chip integrated on the Intel 82810E chipset. Features include:

- Direct AGP (integrated AGP)
- Video memory shared with main memory through DVM Technology
- Integrated Hardware Motion Compensation
- 2D/3D graphics
- 4-MB memory
- GMCH with DDM/DDM+.

System Peripherals

The following sections give the specifications for system peripherals.

LCD Panel

Systems come with a 15-inch, high-resolution active matrix twisted nematic (TN) TFT Super Video Graphics Array (SVGA) color display.

Features of the LCD panel include:

- Brightness Adjustments
 - Increase brightness button (four levels of adjustment)
 - Decrease brightness button (four levels of adjustment)
 - Defaults to maximum brightness on power off or unplugging system from the power outlet
- Maximum Viewing Angles
 - Horizontal: 60 degrees from center to right or left side of panel
 - Vertical: 40 degrees from center of panel and upwards, 50 degrees from center of panel and downwards
- Contrast ratio: 200:1 at a 0 degree from normal angle at center
- Luminance/brightness: 200 candlepower per square meter
- Luminance control: 20% ~ 100%
- Pixel pitch: 0.297 mm (horizontal) x 0.297 mm (vertical).

The LCD panel supports the following resolutions:

- 320 x 200 (256/High color), 60-Hz vertical frequency
- 320 x 240 (256/High color), 60-Hz vertical frequency
- 640 x 400 (256/High color), 60-Hz vertical frequency
- 640 x 480 (256/High color/True color), 60-Hz vertical frequency
- 800 x 600 (256/High color/True color), 60-Hz vertical frequency
- 1024 x 768 (256/High color/True color), 60-Hz vertical frequency.

External Monitor

The following resolutions are supported on an optional external monitor:

- 320 x 200 (256/High color), vertical frequency depends on software
- 320 x 240 (256/High color), vertical frequency depends on software
- 640 x 400 (256/High color), vertical frequency depends on software
- 640 x 480 (256/High color/True color), 60-/75-/85-Hz vertical frequency
- 800 x 600 (256/High color/True color), 60-/75-/85-Hz vertical frequency
- 1024 x 768 (256/High color/True color), 60-/75-/85-Hz vertical frequency
- 1280 x 1024 (256/High color/True color), 60-/75-Hz vertical frequency
- 1600 x 1200 (256), 60-/75-Hz vertical frequency

Keyboard

Systems come with a PS/2-compatible keyboard.

- Function keys
- Cursor control keys
- Numeric keypad
- Windows keys
- Typewriter keys

Mouse

Systems come with a PS/2-compatible mouse.

Diskette Drive

Systems come with a 1.44-MB Mobile Diskette Drive.

- Capacity
 - High density mode:
 - Unformatted: 2.00/1.00 MB
 - Formatted: 1440 KB (512B 18 Sec)
 - 720 KB (256B 18 Sec)
 - Normal density mode:
 - Unformatted: 1.00/0.50 MB
 - Formatted: 640 KB (256B 16 Sec)
 - 20 KB (128B 16 Sec)
- Data transfer rate
 - High density mode: 500/250 Kbit/sec
 - Normal density mode: 250/125 Kbit/sec

Hard Drive

Systems come with a Mobile EIDE Ultra DMA/66 hard drive. The specifications for the mobile hard drive vary, depending on the manufacturer and size of the installed drive.

CD-ROM Drive

Systems come with a Mobile ATAPI CD-ROM drive. The specifications for the mobile CD-ROM drive vary, depending on the manufacturer and speed of the installed drive.

 **CAUTION** Use of CD-ROM drive controls, adjustments, or the performance of procedures other than those specified in this document may result in hazardous radiation exposure.

Combo Drive

Some systems might come with an optional combination DVD-ROM and CD-RW drive. The specifications for the combination drive vary, depending on the manufacturer and speed of the installed drive.

PC Card Slots

Systems come with two CardBus card slots that support:

- Two Type II PC Cards or one Type III PC Card
- 32-bit CardBus and 16-bit PC Card technology.

Speakers

Systems come with two Pioneer 1-watt speakers integrated in the base of the LCD panel. Features include:

- 16-bit stereo, 48 KHz
- Sound Blaster compatible.

Dimensions

System

Base chassis — 10.75 inches (274.1mm) wide x 7.5 inches (192mm) deep x 2.75 inches (70mm) high

Total height (with LCD panel) — 15.6 inches (395mm)

Weight — approximately 12 lb.

Keyboard

Height — 1.4 in. (35.6mm)

Width — 18.0 in. (457.2mm)

Depth — 6.7 in. (170.2mm)

Weight — 3.5 to 4 lb.

Power

AC Adapter with built-in power converter and detachable AC power cord

- AC power input — 100 - 240 Volt, 50-60 Hz, 1.4 amps
- DC power output — 19 Vdc, 4.74 amps, 80 watts
- Power management — full-power reduction

Operating Environment

Temperature — 32° F to 95° F (0° C to 35° C)

Relative humidity — 8% to 80%

Compliance

Domestic:	FCC CFR 47 Part 15, Subpart B UL 1950 3rd edition
Canadian:	C-UL C22.2 No.950-95 ICES-003 Issue 2, Revision 1
Year 2000:	YMARK 2000 NEC Y2KTEST.EXE WHQL
DMI	DMI 2.3 Self Certification Test Suite
Energy Star	All systems are Energy Star Compliant

Index

A

Acrobat reader, 1-17
AGP graphics, 1-15
Anti-theft bracket, 1-8
 features, 1-8
Application and Driver CD, 3-29
Audio
 connectors, 1-8
 features, 1-8
 subsystem, 1-15

B

Battery
 CMOS, 3-4
 problems, 5-3
BIOS
 Advanced Menu, 3-12
 Boot Menu, 3-22
 Exit Menu, 3-24
 FLASH ROM, 1-15
 Main Menu, 3-6
 Power Menu, 3-21
 Security Menu, 3-17
 Setup Utility, 3-4
 updates, 3-28
Booting problems, 5-3, 5-4
Bracket
 system mount, 1-14
Browser
 Microsoft Internet Explorer, 1-16

C

Cache memory, B-2
Calendar clock
 specifications, B-2
CD disc
 emergency eject, 5-6

CD-ROM drive
 controls, 1-6
 problems, 5-6
 specifications, B-7, B-8
Chair, adjusting, A-4, A-11
Chassis
 features, 1-14
Checking system memory, 4-8
Cleaning
 keyboard, 2-6
 LCD panel, 2-6
 mouse, 5-7
 system exterior, 2-6
CMOS battery, 3-4
Combo drive
 features, 1-6
Compliance
 PC99, 1-15
 specifications, B-9
Configuration
 BIOS Setup Utility, 3-4
 FLASH Utility, 3-28
 tools and utilities, 3-2
Connectors
 audio, 1-8
 DC power, 1-12
 Kensington security lock slot, 1-11
 keyboard, 1-11
 LAN, 1-11, 2-2
 mouse, 1-11
 network, 2-2
 optional modem, 1-12
 printer, 1-11
 serial port, 1-11
 USB, 1-8
 VGA, 1-12

- Controls and lamps
 - hard drive lamp, 1-4
 - power/sleep button, 1-4
 - power/sleep lamps, 1-4

D

- Date
 - incorrect, 5-3
- DC power connector, 1-12
- Dimensions
 - keyboard, B-8
 - system, B-8
- Disk error problems, 5-2, 5-4
- Diskette
 - FLASH, 3-28
- Diskette drive
 - description, 1-5
 - problems, 5-4
 - specifications, B-7
- Display modes, 1-5, B-5
- Drives
 - CD-ROM, 1-6
 - combo drive, 1-6
 - diskette, 1-5
 - hard disk, 1-8
- DVMT, 1-14, 1-15
- Dynamic Video Memory
 - Technology, 1-14

E

- Email/fax service, 6-3
- Emergency eject
 - CD disc, 5-6
- Ergonomics
 - chair adjustments, A-4, A-11
 - checking you, A-12
 - keyboard adjustments, A-6, A-12
 - monitor adjustments, A-8, A-12
 - mouse adjustments, A-6, A-12
 - workspace setup, A-3
- Expansion devices
 - adding, 4-2
 - adding memory, 4-7

- adding monitor, 4-15
- adding PC Cards, 4-4
- adding printer, 4-15
- adding serial devices, 4-15
- adding USB devices, 4-3
- safety precautions, 4-2
- Exterior, cleaning, 2-6

F

- Fans
 - system cooling, 1-10
- Features
 - bottom, 1-13
 - front, 1-2
 - LCD panel, 1-14
 - left side, 1-9
 - rear, 1-10
 - right side, 1-7
 - software, 1-16
- FLASH diskette, 3-28
- FLASH ROM
 - specifications, B-2
- FTP site
 - entering, 6-3
- Full disk restore
 - performing, 3-32

G

- Graphics controller
 - specifications, B-5

H

- Hard drive
 - activity lamp, 1-4
 - features, 1-8
 - installing, 4-14
 - removing, 4-12
 - security, 1-18, 3-25
 - specifications, B-7
 - spin down, 2-6

Hardware features, 1-15
Healthy work environment, A-2
Help
 24-hour services, 6-2

I

I/O specifications, B-3
Intel Processor Serial Number
 Control Utility, 3-37

J

Jumper
 password clear, 1-14
 settings, 3-36

K

Kensington security lock slot, 1-11,
 1-18
Keyboard
 adjusting, A-6, A-12
 cleaning, 2-6
 problems, 5-5
 setup, 2-2
 specifications, B-6

L

Lamps and controls
 hard drive lamp, 1-4
 power/sleep button, 1-4
 power/sleep lamps, 1-4
LAN
 connector, 1-11, 2-2
 features, 1-11
LCD panel
 brightness buttons, 1-5
 cleaning, 2-6
 features, 1-14
 problems, 5-5
 specifications, B-5
LCD/VGA monitor
 simultaneous viewing, 1-5

M

Memory
 checking, 4-8
 sockets, 1-13
 SO-DIMMs, 4-7
 specifications, B-2
 system, 1-14, 1-15, 4-7
 total system, 4-7
 upgrading, 4-7
 video, 1-14, 1-15, 4-7
Menu
 Advanced, 3-4, 3-12
 Boot, 3-5, 3-22
 Exit, 3-5, 3-24
 Main, 3-4, 3-6
 Main setup, 3-4
 Power, 3-5, 3-21
 Security, 3-5, 3-17
Microdesktop chassis
 features, 1-14
Microsoft
 Internet Explorer browser, 1-16
Modem board
 specifications, B-4
Modem, optional
 features, 1-12
Modules
 memory, 1-13
Monitor
 adding, 4-15
 adjusting, A-8, A-12
 supported resolutions, B-6
Mouse
 adjusting, A-6, A-12
 cleaning, 5-7
 problems, 5-5
 setup, 2-2
 specifications, B-7
Moving
 preparations, 2-7

N

- NEC Computers
 - email/fax service, 6-3
 - FTP site, 6-3
 - technical support services, 6-4
 - web site, 6-2
- NEC Customize Utility, 3-28
- NEC INFO Center, 1-17, 3-30
 - uninstalling, 3-31
- NEC Product Recovery CD, 1-16
- Network board
 - specifications, B-4
- Network setup, 2-2

O

- Online documentation, 1-17
- Operating environment, B-9

P

- Password
 - clear jumper, 1-14
 - clearing, 3-36
 - problems, 5-4
 - types, 1-17
- PC Card
 - inserting, 4-4
 - removing, 4-6
 - slot specifications, B-8
- PC Card slot
 - features, 1-9
- PC99 compliance, 1-15
- Power
 - management, 1-15
 - problems, 5-2
 - setup, 2-2
 - sleep mode, 2-4
- Power supply
 - 80 watt, 1-14
 - specifications, B-9
- PowerMate Application and Driver CD, 1-16
- Printer
 - adding, 4-15

- port features, 1-11

Problems

- booting, 5-3, 5-4
 - CD-ROM drive, 5-6
 - common, 5-2
 - date, incorrect, 5-3
 - disk error, 5-2, 5-4
 - diskette drive, 5-4
 - keyboard/mouse, 5-5
 - LCD panel, 5-5
 - password, 5-4
 - power, 5-2
 - solutions, 5-2
 - speakers, 5-7
 - system, 5-2
 - time, incorrect, 5-3
- Processor, 1-15
 - Processor Serial Number Control Utility, 3-37
 - Product Recovery CD
 - full disk restore, 3-32
 - using, 3-31
 - PS/2 keyboard port
 - features, 1-11
 - PS/2 mouse port
 - features, 1-11

Q

- Quick reference
 - system information, 2-8

R

- Resolutions
 - LCD panel, B-6
 - monitor, B-6

S

- Safety precautions, 4-2
- Security
 - anti-theft bracket, 1-18
 - features, 1-17

-
- hard drive, 1-18, 3-25
 - password, 1-17
 - Windows, 1-18
 - Serial device
 - adding, 4-15
 - Serial port
 - features, 1-11
 - Service
 - direct assistance, 6-4
 - email/fax, 6-3
 - Settings
 - system board jumper, 3-36
 - Setup
 - keyboard, 2-2
 - mouse, 2-2
 - network, 2-2
 - power, 2-2
 - Setup Utility
 - BIOS, 3-4
 - legend bar, 3-5
 - Main Menu, 3-4
 - startup, 3-4
 - using, 3-4
 - Shipping, 2-7
 - preparations, 2-7
 - safety precautions, 2-7
 - Shutdown
 - power off, 2-3
 - Windows 98 or Windows 2000, 2-4
 - Windows NT, 2-4
 - Sleep mode
 - power reduction, 1-4
 - power saving, 2-4
 - Sockets
 - memory, 1-13
 - SO-DIMMs
 - installing, 4-8
 - memory modules, 1-13
 - removing, 4-11
 - upgrading, 4-7
 - Software
 - Acrobat Reader, 1-17
 - features, 1-16
 - Microsoft Internet Explorer, 1-16
 - Norton AntiVirus, 1-17
 - Sound controller
 - specifications, B-4
 - Speakers
 - location of, 1-6
 - problems, 5-7
 - specifications, B-8
 - volume control, 1-6
 - Specifications
 - cache memory, B-2
 - calendar clock, B-2
 - CD-ROM drive, B-7, B-8
 - compliance, B-9
 - diskette drive, B-7
 - FLASH ROM, B-2
 - graphics controller, B-5
 - hard drive, B-7
 - I/O, B-3
 - keyboard, B-6
 - keyboard dimensions, B-8
 - LCD panel, B-5
 - LCD panel resolutions, B-6
 - modem board, B-4
 - mouse, B-7
 - network board, B-4
 - operating environment, B-9
 - PC Card slots, B-8
 - PC Cards, B-8
 - power, B-9
 - processor, B-2
 - sound controller, B-4
 - speakers, B-8
 - system board, B-2
 - system dimensions, B-8
 - system memory, B-2
 - system peripherals, B-5
 - video memory, B-3
 - Spin down
 - hard drive, 2-6
 - Startup
 - power on, 2-2

Surge suppressor, connecting, 2-5

System

- cleaning, 2-6
- maintaining condition, 2-6
- problems, 5-2
- protecting from damage, 2-5

System features

- anti-theft bracket, 1-8
- audio, 1-8
- bottom, 1-13
- cooling fans, 1-10
- front, 1-2
- hard drive, 1-8
- hardware, 1-15
- LAN, 1-11
- left side, 1-9
- memory, 4-8
- optional modem, 1-12
- overview, 1-15
- PC Card slots, 1-9
- printer port, 1-11
- processor, 1-15
- PS/2 keyboard port, 1-11
- PS/2 mouse port, 1-11
- rear panel, 1-10
- right side, 1-7
- security, 1-17
- serial port, 1-11
- USB ports, 1-8
- VGA, 1-12
- volume control, 1-7

System peripherals

- specifications, B-5

T

Technical support services, 6-4

Temperatures

- operating, 2-6

Time

- incorrect, 5-3

Troubleshooting

- battery, 5-3
- booting, 5-3, 5-4

CD-ROM drive, 5-6

common problems, 5-2

date, incorrect, 5-3

disk error, 5-2, 5-4

diskette drive, 5-4

keyboard/mouse, 5-5

LCD panel, 5-5

password, 5-4

power, 5-2

solutions, 5-2

speakers, 5-7

system problems, 5-2

time, incorrect, 5-3

U

Universal serial bus ports

- features, 1-8

Upgrading

BIOS, 3-28

SO-DIMMs, 4-7

USB devices

- adding, 4-3

Utility

BIOS Setup, 3-4

configuration, 3-2

V

VGA monitor

connector, 1-12

simultaneous viewing with LCD
panel, 1-5

Video memory, 1-14, 4-7

specifications, B-3

Virus scan

software, 1-17

Volume control

features, 1-7

W

Web site

NEC Computers, 6-2

Windows

2000, 1-16

98 SE, 1-16

NT, 1-16

security, 1-18

Regulatory Statements

The following regulatory statements include the Federal Communications Commission (FCC) Radio Frequency Interference Statement, compliance statements for Canada and Europe, battery disposal and replacement information, and the Declaration of Conformity.

FCC Statement for United States Only

 **WARNING** Changes or modifications to this unit not expressly approved by the party responsible for compliance could void the user's authority to operate the equipment.

Note This equipment has been tested and found to comply with the limits for a Class B digital device, pursuant to Part 15 of the FCC Rules. These limits are designed to provide reasonable protection against harmful interference in a residential installation. This equipment generates, uses and can radiate radio frequency energy and, if not installed and used in accordance with the instructions, may cause harmful interference to radio communications.

However, there is no guarantee that interference will not occur in a particular installation. If this equipment does cause harmful interference to radio or television reception, which can be determined by turning the equipment off and on, the user is encouraged to try to correct the interference by one or more of the following measures.

- Reorient or relocate the receiving antenna.
- Increase the separation between the equipment and receiver.
- Connect the equipment to an outlet on a circuit different from the one to which the receiver is connected.
- Consult the dealer or an experienced radio/TV technician for help.

Canadian Department of Communications Compliance Statement

This Class B digital apparatus meets all requirements of the Canadian Interference-Causing Equipment Regulations (pursuant to ICES-003 Issue 2, Revision 1).

Avis de conformité aux normes du ministère des communications du Canada

Cet équipement numérique de la Classe B respecte toutes les exigences du Règlement sur le matériel brouillage du Canada (en conformité avec ICES-003 Emission 2, Révision 1).

European Community Directive Conformance Statement

This product is in conformity with the protection requirements of EC Council Directive 89/336/EEC on the approximation of laws of the Member States relating to electro-magnetic compatibility. This product satisfied the Class B limits of EN55022.

Battery Replacement

A lithium battery maintains system configuration information. In the event that the battery fails to maintain system configuration information, NEC Computers recommends that the battery be replaced. For battery replacement information, call the NEC Computers Technical Support Center (see Chapter 6 for Technical Support Center information).



WARNING There is a danger of explosion if the battery is incorrectly replaced. Replace only with the same or equivalent type recommended by the manufacturer. Discard used batteries according to the manufacturer's instructions.



AVERTISSEMENT Il y a danger d'explosion s'il y a remplacement incorrect de la batterie. Remplacer uniquement avec une batterie du même type ou d'un type recommandé par le constructeur. Mettre au rebut les batteries usagées conformément aux instructions du fabricant.

Battery Disposal

The CMOS battery is made of lithium. Contact your local waste management officials for other information regarding the environmentally sound collection, recycling, and disposal of the batteries.

NEC Computers Inc.

DECLARATION OF CONFORMITY

We, the Responsible Party

NEC Computers Inc.
15 Business Park Way
Sacramento, CA 95828

declare that the product

NEC PowerMate 2000

is in compliance with FCC CFR47 part 15 for Class B
digital devices.