



N8800-048E/049E

**NEC Express5800/320Lb/320Lb-R
User's Guide (Setup)**

1st Edition
10-2004
856-124164-901-A

PROPRIETARY NOTICE AND LIABILITY DISCLAIMER

The information disclosed in this document, including all designs and related materials, is the valuable property of NEC Corporation (NEC) and /or its licensors. NEC and/or its licensors, as appropriate, reserve all patent, copyright and other proprietary rights to this document, including all design, manufacturing, reproduction, use, and sales rights thereto, except to the extent said rights are expressly granted to others.

The NEC product(s) discussed in this document are warranted in accordance with the terms of the Warranty Statement accompanying each product. However, actual performance of each such product is dependent upon factors such as system configuration, customer data, and operator control. Since implementation by customers of each product may vary, the suitability of specific product configurations and applications must be determined by the customer and is not warranted by NEC.

To allow for design and specification improvements, the information in this document is subject to change at any time, without notice. Reproduction of this document or portions thereof without prior written approval of NEC is prohibited.

First Printing, October 2004
Copyright 2004
NEC Corporation
7-1 Shiba 5-Chome, Minato-Ku
Tokyo 108-8001, Japan
All Rights Reserved
Printed in Japan



Keep this User's Guide handy for quick reference when necessary.

Safety Indications



To use NEC Express5800 Series safely, follow the instructions in this User's Guide.

This guide explains components that pose a danger, types of dangers caused by failing to follow the instructions, and actions taken to prevent them; such components are labeled warning.

This guide and warning labels use "WARNING" and "CAUTION" to indicate a danger depending on the degree. These terms are defined as follows:



 WARNING	Indicates a danger that could lead to a death or serious injury.
 CAUTION	Indicates a danger that could lead to a burn, other injuries or damage to physical assets.

This guide uses the following three types of symbols to give indications and precautions against a danger. They are defined as follows:

	Indicates that a failure to follow the instructions could cause a danger. Each image symbolizes a particular type of danger. (Attention)
	Indicates what you must not do. Each image symbolizes a particular type of prohibition. (Prohibited actions)
	Indicates what you must do. Each image symbolizes a particular type of action necessary to avoid a danger. (Mandatory actions)

(Example)







Symbol to draw attention
Term indicating a degree of danger

 CAUTION	
	High temperature. Immediately after the power-off, system components such as hard disk are very hot. Wait the server to cool down completely before adding/re moving some component.



Symbol indicating a prohibited action (may not always be indicated) Description of a danger

Symbols and its descriptions used in this User's Guide and warning labels are as follows:



Attention

	Indicates a risk of an electric shock.
	Indicates a risk of an injury due to heat.
	Indicates a risk of catching your fingers.
	Indicates a risk of a fire or smoke.
	Indicates a general precaution or warning that is not defined herein.
	Indicates a risk of losing eyesight due to laser beam.
	Indicates a risk of an injury or damage to physical assets due to a hazardous material.

Prohibited actions

	Indicates a general prohibition that is not defined herein.
	Do not disassemble, repair, or modify the equipment. Otherwise, there is a risk of an electric shock or fire.

Mandatory actions

	Unplug the server. Otherwise, there is a risk of an electric shock or fire.
	Indicates a general action to take that is not defined herein. Make sure to follow the instructions.

For detailed notes to set up the machine safely, refer to “Notes for Safe Handling” on page 1-2.

NOTE: This equipment has been tested and found to comply with the limits for a Class A digital device, pursuant to Part 15 of the FCC Rules. These limits are designed to provide reasonable protection against harmful interference when the equipment is operated in a commercial environment. This equipment generates, uses, and can radiate radio frequency energy and may cause harmful interference to radio communications. Operation of this equipment in a residential area is likely to cause harmful interference in which case the user will be required to correct the interference at his own expense.

警告使用者：

這是甲類的資訊產品，在居住的環境中使用時，可能會造成射頻干擾，在這種情況下，使用者會被要求採取某些適當的對策。

이 기기는 업무용으로 전자파적합등록을 한 기기이오니 판매자 또는 사용자는 이 점을 주의하시기 바라며 만약 잘못된 판매 또는 구입하였을 때에는 가정용으로 교환하시기 바랍니다.

This class A digital apparatus meets all requirements of the Canadian Interference-Causing Equipment Regulations.

Cet appareil numérique de la classe A respecte toutes les exigences du Règlement sur le matériel brouilleur du Canada.

CE Statement

Warning: This is a Class A product. In residential environment, this product may cause radio interference, in which case the user may be required to take adequate measures (EN55022).

NOTE: This product provides resistance against hardware faults with its redundant hardware modules. However, this does not mean complete fault-tolerance is assured. For example, there is a risk of system down when:

- A fatal fault occurs in software.
- Both modules within a redundant hardware pair break down.
- A fatal fault occurs in a non-redundant component, such as the clock generator circuitry or the interconnect backplane.
- The entire system is cut off from AC power.

Trademarks

NEC ESMPRO, NEC EXPRESSBUILDER, and NEC Express5800/ft series are trademarks of NEC Corporation. Microsoft, Windows, Windows Server, Windows NT, and MS-DOS are registered trademarks of Microsoft Corporation in the United States and other countries.

Intel and Pentium are registered trademarks of Intel Corporation. Xeon is a trademark of Intel Corporation in the United States. Adobe, the Adobe logo, Acrobat, and the Acrobat logo are trademarks of Adobe Systems Incorporated.

AT is a registered trademark of International Business Machines Corporation in the United States and other countries.

Stratus is a registered trademark of Stratus Technologies Bermuda Ltd. Datalight is a registered trademark of Datalight, Inc. Linux is a registered trademark of Linus Torvalds. Red Hat and RPM are trademarks or registered trademarks of Red Hat, Inc. in the United States and other countries.

All other product, brand, or trade names used in this publication are the trademarks or registered trademarks of their respective trademark owners.

Names used with sample applications are all fictitious. They are unrelated to any existing product names, names of organizations, or individual names.

DLT and DLTtape are trademarks of Quantum Corporation in the United States. QLogic and its logo are trademarks of QLogic Corporation in the United States. Fast!UTIL is a trademark of QLogic Corporation in the United States. ROM-DOS is a trademark of Datalight, Inc.

Most of the software used for this server can be redistributed freely under the terms of the BSD Copyright and the GNU Public License. However, some software requires permissions for redistribution as the owners have ownership. For details, see "Introduction" in the attachment.

Notes:

- (1) No part of this manual may be reproduced in any form without prior written permission of NEC Corporation.
- (2) The contents of this manual are subject to change without prior notice.
- (3) The contents of this manual shall not be copied or altered without prior written permission of NEC Corporation.
- (4) All efforts have been made to ensure the accuracy of all information in this manual. If you find any part unclear, incorrect, or omitted in this manual, contact the sales agent where you purchased this product.
- (5) NEC assumes no liability arising from the use of this product, nor any liability for incidental or consequential damage arising from the use of this manual regardless of (4) above.

Preface

Welcome to the NEC Express5800/ft series.

NEC Express5800/ft series is a “fault-tolerant (ft)” server focusing on “high reliability” in terms of fault-tolerance, in addition to “high performance,” “scalability,” and “general versatility” provided by NEC Express5800 series. In the event of trouble, its dual configuration will allow the system to instantaneously isolate the failed parts to assure non-stop running; operation will be moved smoothly from one module to the other, minimizing damage to it. You can use NEC Express5800/ft series in a mission-critical system where high availability is required. By the use of Linux operating system, it also provides outstanding openness for general-purpose applications, etc.

To make the best use of these features, read this User's Guide thoroughly to understand how to operate NEC Express5800/ft series.

About This User's Guide

This User's Guide helps a user to properly setup and use the product. Consult this guide when you set up the product.

Keep this manual and the separate volume of User's Guide handy.

This User's Guide is intended for users who have a good knowledge on the basic use of Linux operating systems and general I/O devices such as a keyboard and mouse.

How to Use This User's Guide

This guide explains the procedures you should perform before you begin system operation after you purchased the product. Read the guide in order from Chapter 1. If you perform procedures according to this guide, you will set up the product properly.

Chapter 4 describes how to install the operating system. Chapter 5 describes post-installation procedures. Chapter 6 explains how to troubleshoot if you cannot set up the product properly. Refer to "System Repair" on page 6-2 for details about system configurations and repairs of this product. Refer to "Troubleshooting" on page 6-3 if you feel you failed to set up the product.

See this User's Guide for details of this product's operation, and functions and operations of the hardware and the system.

Additional symbols

The following symbols are used throughout this User's Guide in addition to the caution symbols described at the beginning.

IMPORTANT:	Important points or instructions to keep in mind when using the server or software
CHECK:	Something you need to make sure when using the server or software
TIPS:	Helpful information, something useful to know

About our Web Service

Information on NEC Express5800/ft series including modification modules is also available on our web site, NEC Express5800 Web Site Asia Pacific, at

<http://www.nec.co.jp/epxpress/index.html>

Contents

Safety Indications	iii
Preface	i
About This User's Guide	ii
How to Use This User's Guide.....	ii
Additional symbols.....	iii
About our Web Service	iii
Contents	v
CHAPTER 1 BEFORE SETUP	1-1
Notes for Safe Handling	1-2
Warning Labels.....	1-2
Precautions for Safety	1-8
General	1-8
Use of Power Supply and Power Cord	1-10
Installation, Relocation, Storage and Connection.....	1-11
Cleaning and Handling of Internal Devices.....	1-13
During Operation.....	1-14
Rack-mount Model	1-15
Unpackaging	1-16
Accessories	1-16
Main unit	1-16
CHAPTER 2 ABOUT OPERATING SYSTEM	2-1
Installing Linux for NEC Express5800/ft series	2-2
About OS installation	2-2
CHAPTER 3 INSTALLING SERVER	3-1
Installation	3-2
Tower Model	3-2
Installation of Rack-mount Model.....	3-5
Connection.....	3-8
CHAPTER 4 LINUX SETUP	4-1
Setup Flow	4-2

Setup Procedure When Powering on the NEC Express5800/ft series for the First Time	4-3
Step A-1: Starting Setup Procedure When Powering on the Server for the First Time	4-3
Setup Procedure When Reinstalling the OS	4-5
Step B-1: Starting Setup Procedure When Reinstalling the OS	4-5
Step B-2: Prepare for Installation.....	4-6
Step B-3: Start the Installation of Linux for NEC Express5800/ft series.....	4-9
Step C-1: Set Dual LAN Card Configuration	4-10
Step C-2: Set Dual Disk Configuration.....	4-13
Step C-3: Connect and Configure Options.....	4-19
Step C-4: Create Volume	4-19
Step C-5: Set Network for NEC ESMPRO Agent	4-19
Step C-6: Back up System Information	4-20
CHAPTER 5 PROCEDURES AFTER COMPLETION OF INSTALLATION	5-1
Installing Management Utilities	5-2
NEC ESMPRO Agent.....	5-2
NEC ESMPRO Manager	5-7
NEC MWA	5-8
Confirmation of the Kernel Version.....	5-10
CHAPTER 6 TROUBLESHOOTING	6-1
System Repair.....	6-2
Troubleshooting.....	6-3
Problems with NEC EXPRESSBUILDER	6-3
APPENDIX A ABOUT SERVICES	A-1

Chapter 1

Before Setup

This chapter includes information necessary for proper and safe operation of the server, the main unit and its accessories. Go through this chapter before you start setup of the product.

Notes for Safe Handling

The following section describes necessary information to use the product properly and safely.

Warning Labels

Warning labels are placed in certain parts of the system so that the user stays alert to possible risks (Do not remove or damage these labels).



If some label is missing, about to peel off, or illegible, contact your sales agent.

The figures below show locations of the labels on tower model and rack-mount model servers.

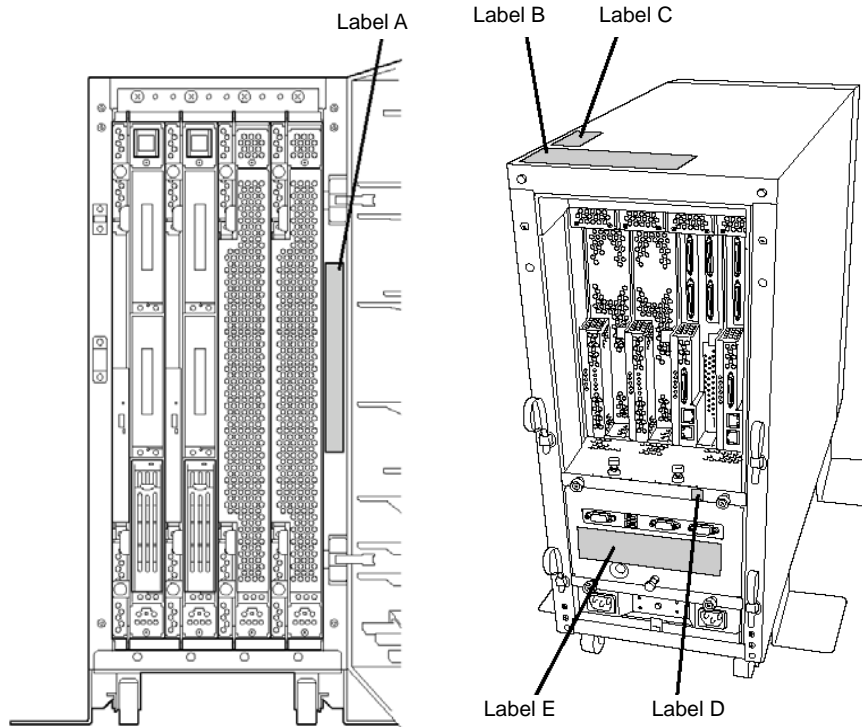
Tower Model



Label A

 注意 CAUTION 	<p>为防止触电及火灾，关于模块/线缆的安装/拆卸，请参考操作说明书。</p> <p>In order to prevent electrical shock or fire hazards, disconnect all cables connected with the module to be serviced.</p>
---	--

Label B

 注意 CAUTION  
<p>请小心不要夹住或碰伤手指。 Exercise caution when handling the system to avoid personal injuries.</p>
<p>设备运行时以及刚切断电源后，硬盘表面温度会很高，请一定注意。 As the hard disk drives may retain heat after powering down, allow ample time for cooling prior to handling.</p>
<p>对 CPU 模块、PCI 模块、电源模块以外的部件进行维护时，为防止触电，请拨下所有电源线 and 外接线缆。 In order to prevent accidents such as electrical shock, disconnect all cables and external connections when servicing non-hotswappable modules.</p>
<p>有的部件可能会达到高温，请注意待其冷却之后再接触。 As some components may become very hot during system operation, give ample time to allow cooling as well as use precatation when handling internal components immediately after powering down.</p>
<p>请一定注意不要把螺丝掉落在主机内部，否则可能会引起火灾。 In order to prevent short circuits and fire hazards, exercise caution and avoid dropping screws inside the system.</p>

Label C

 警告 WARNING
<p> 只有维护员方可对本设备进行拆卸，否则可能会引起触电等事故。 Risk of electric shock - do not open.</p>
<p> Qualified service personnel only. No user servicable components inside.</p>

Label D





Label E

 注意 CAUTION	
<p>本设备连接有多个电源线。在进行维护时为防止触电，请务必拔掉所有电源线。</p> <p>This unit uses multiple power supply cords. Disconnect all power supply cords prior to Servicing this system</p>	

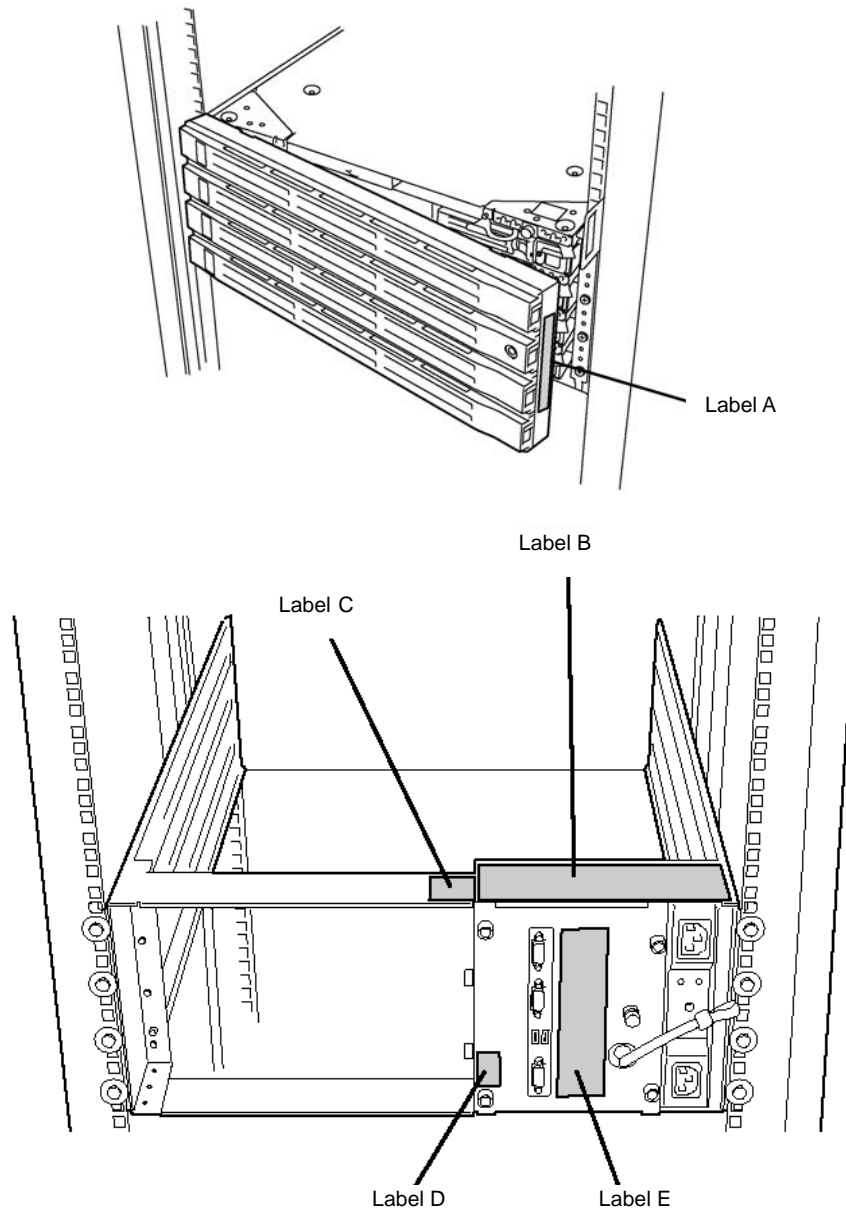
Rack-mount Model



Label A

 注意 CAUTION 	为防止触电及火灾，关于模块/线缆的安装/拆卸，请参考操作说明书。 In order to prevent electrical shock or fire hazards, disconnect all cables connected with the module to be serviced.
---	---

Label B

 注意 CAUTION   
请小心不要夹住或碰伤手指。 Exercise caution when handling the system to avoid personal injuries.
设备运行时以及刚切断电源后，硬盘表面温度会很高，请注意。 As the hard disk drives may retain heat after powering down, allow ample time for cooling prior to handling.
对 CPU 模块、PCI 模块、电源模块以外的部件进行维护时，为防止触电，请拔下所有电源线和外接线缆。 In order to prevent accidents such as electrical shock, disconnect all cables and external connections when servicing non-hotswappable modules.
有的部件可能会达到高温，请注意待其冷却之后再接触。 As some components may become very hot during system operation, give ample time to allow cooling as well as use precaution when handling internal components immediately after powering down.
请一定要注意不要把螺丝掉落在主机内部，否则可能会引起火灾。 In order to prevent short circuits and fire hazards, exercise caution and avoid dropping screws inside the system.

Label C

 警告 WARNING
 只有维护员方可对本设备进行拆卸，否则可能会引起触电等事故。 Risk of electric shock - do not open.
 Qualified service personnel only. No user serviceable components inside.

Label D



Label E

 注意 CAUTION	
本设备连接有多个电源线。在进行维护时为防止触电，请务必拔掉所有电源线。 This unit uses multiple power supply cords. Disconnect all power supply cords prior to Servicing this system	

PCI/CPU Modules

PCI Module

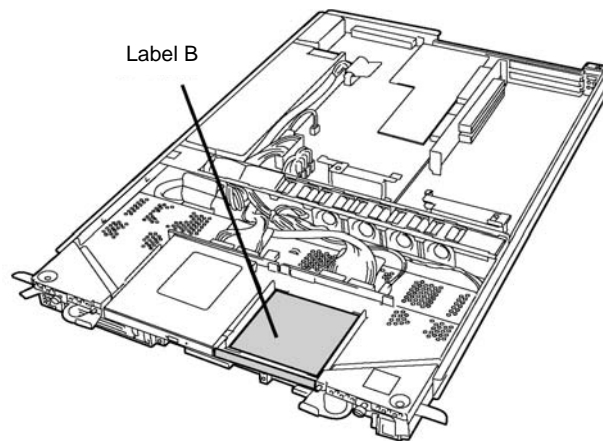
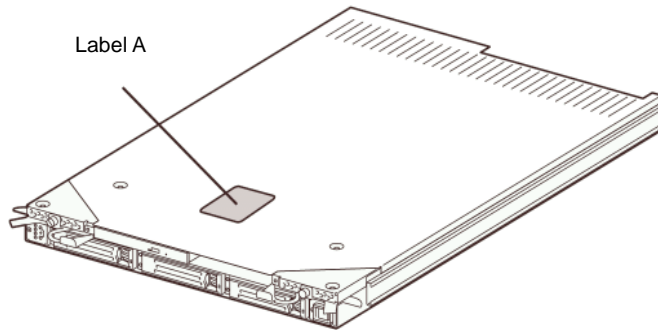

CPU Module

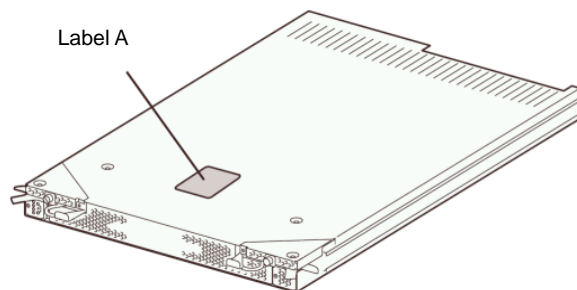

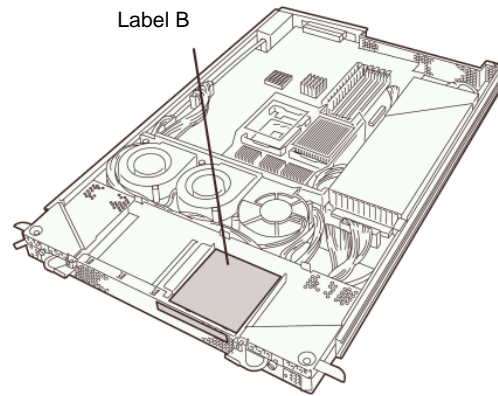

Label A



Label B



Precautions for Safety

This section provides precautions for using the server safely. Read this section carefully to ensure proper and safe use of the server. For symbol meanings, see "Safety Indications" described in the previous section.

General

 **WARNING**



Do not use the equipment in an operation where human lives are involved or high reliability is required.

This equipment is not intended for use in controlling or use with facilities or systems where human lives are involved or high reliability is required, including medical devices or nuclear, aerospace, transportation, and traffic control facilities. NEC assumes no liability for any accidents or damage to physical assets resulting from the use of this equipment in such systems or facilities.



Do not continue to use the equipment if you detect smoke, odor, or noise.

If the equipment emits smoke, odor, or noise, immediately flip off the POWER switch, unplug the cord, and contact your sales agent. There is a risk of a fire.



Do not insert a wire or metal object.

Do not insert a wire or metal objects into a vent or disk drive slot. There is a risk of an electric shock.



Do not use the equipment in an unsuitable place.

Do not install a server rack in an unsuitable environment. Otherwise, other systems also may be affected, and the rack may fall over to cause a fire or injuries. For details about installation environment and quake-resistant engineering, see the attached manual or contact your sales agent.



Do not install the equipment on a nonconforming rack.

Install the equipment on a 19-inch rack confirming to the EIA standard. Do not use the equipment without a rack or install it on a nonconforming rack. Otherwise, the equipment may not function properly, and there is a risk of damage to physical assets or injuries. For suitable racks, contact your sales agent.

 **CAUTION**



Prevent water or foreign objects from getting into the equipment.

Do not let water or foreign objects (e.g., pins or paper clips) enter the equipment. There is a risk of a fire, electric shock, and breakdown. When such things accidentally enter the equipment, immediately turn off the power and unplug the cord. Contact your sales agent instead of trying to disassemble it yourself.

Use of Power Supply and Power Cord

WARNING



Do not handle a power plug with a wet hand.

Do not plug/unplug a power cord with a wet hand. There is a risk of an electric shock.



Do not connect the ground wire to a gas pipe.

Never connect the ground wire to a gas pipe. There is a risk of a gas explosion.

CAUTION



Do not plug the cord in a nonconforming outlet.



Use a wall outlet with specified voltage and power type. Otherwise, there is a risk of a fire or current leakage.

Avoid installing the equipment where you may need an extension cord. If the cord that does not meet the power specifications, there is a risk of overheating that could lead to a fire.



Do not plug too many cords in a single outlet.

If the rated current is exceeded, there is a risk of overheating that could lead to a fire.



Do not plug the cord insecurely.

Insert the plug firmly into an outlet. Otherwise, there is a risk of heat or fire due to poor contact. If dust settles on the slots and it absorbs moisture, there is also a risk of heat or fire.



Do not use nonconforming power cords.



Use only the power cords that come with the product. If the rated current is exceeded, there is a risk of a fire.

You also have to observe the following prohibitions to prevent damage to the cords.

- Do not pull on the cord.
- Do not pinch the cord.
- Do not bend the cord.
- Keep chemicals away from the cord.
- Do not twist the cord.
- Do not place any object on the cord.
- Do not bundle several cords.
- Do not alter, modify, or repair the cord.
- Do not staple the cord.
- Do not use any damaged cord. (Replace it with a new one of the same specifications. For replacement procedures, contact your sales agent.)

Installation, Relocation, Storage and Connection

WARNING



Disconnect the power cord(s) before installing or removing the equipment.
Be sure to power off the equipment and unplug its power cords from the wall outlet before installation/relocation. All voltage is removed only when the power cords are unplugged.

CAUTION



Do not hold the front bezel to lift the equipment.

The equipment weighs approximately 70 kg (depending on its hardware configuration). Do not hold the front bezel, or it may become detached, causing an injury. For lifting and moving the equipment, remove the mounted modules from the main unit and carry them separately. It takes at least two people to carry it; hold the equipment firmly by its bottom.



Do not install the equipment in an unsuitable place.

Install the equipment in such a place as specified in this User's Guide. Avoid the following, or there is a risk of a fire.

- a dusty place
- a humid place located near a boiler, etc
- a place exposed to direct sunlight
- an unstable place



Be careful not to hurt your fingers.

Exercise great care not to hurt your fingers on the rail when you mount/dismount the equipment into/from the rack.

⚠ CAUTION



Do not connect any interface cable with the power cord of the server plugged to a power source.



Make sure to power off the server and unplug the power cord from a power outlet before installing/removing any optional internal device or connecting/disconnecting any interface cable to/from the server. If the server is off-powered but its power cord is plugged to power source, touching an internal device, cable, or connector may cause an electric shock or a fire resulted from a short-circuit.



Do not use any non-designated interface cable.

Use only interface cables designated by NEC; identify which component or connector to attach beforehand. If you use a wrong cable or make a wrong connection, there is a risk of short-circuit that could lead to a fire.

You also have to observe the following prohibitions about handling and connecting interface cables:

- Do not use any damaged cable connector.
- Do not step on the cable.
- Do not place any object on the cable.
- Do not use the equipment with loose cable connections.



Do not use or store this product in a corrosive environment.

Avoid the usage or storage of this product in an environment which may be exposed to corrosive gases, such as those including but not limited to : sulfur dioxide, hydrogen sulfide, nitrogen dioxide, chlorine, ammonia and/or ozone.

Avoid installing this product in a dusty environment or one that may be exposed to corrosive materials such as sodium chloride and/or sulfur.

Avoid installing this product in an environment which may have excessive metal flakes or conductive particles in the air.

Such environments may cause corrosion or short circuits within this product, resulting in not only damage to this product, but may even lead to be a fire hazard.

If there are any concerns regarding the environment at the planned site of installation or storage, please contact your sales agent.

Cleaning and Handling of Internal Devices

WARNING



Do not disassemble, repair, or alter the server.



Unless described herein, never attempt to disassemble, repair, or alter the equipment. There is a risk of an electric shock or fire as well as malfunction.



Do not look into the CD-ROM drive



The CD-ROM drive uses a laser beam. Do not look or insert a mirror inside while the system is on. A laser beam is invisible; if your eyes get exposed to it, there is a risk of losing eyesight.



Do not detach a lithium battery yourself.

This equipment has a lithium battery. Do not detach it yourself. If the battery is exposed to fire or water, it could explode.

When the lithium battery is running down and the equipment doesn't work correctly, contact your sales agent instead of disassembling, replacing or recharging it yourself.



Disconnect the power plug before cleaning the server.

Make sure to power off the server and disconnect the power plug from a power outlet before cleaning or installing/removing internal optional devices. Touching any internal device of the server with its power cord connected to power source may cause an electric shock even if the server is off-powered.

Disconnect the power plug from the outlet occasionally and clean the plug with a dry cloth. Heat will be generated if condensation is formed on a dusty plug, which may cause a fire.

CAUTION



High temperature

Immediately after powering off the system, system components such as hard disk may be very hot. Wait for the server to cool down completely before adding/removing components.



Make sure to complete installation.

Firmly install all power cords, interface cables and/or boards. An incompletely installed component may cause a contact failure, resulting in fire and/or smoke.

During Operation

⚠ CAUTION



Do not pull out a device during operation.

Do not pull out or remove a device while it works. There is a risk of malfunction and injuries.



Do not touch the equipment when it thunders.

Unplug the equipment when it threatens to thunder. If it starts to thunder before you unplug the equipment, do not touch the equipment or cables. There is a risk of a fire or electric shock.



Keep animals away.



Animal's waste or hair may get inside the equipment to cause a fire or electric shock.



Do not place any object on top of the server.

The server may fall down to cause damage to physical assets.



Do not leave the CD tray ejected.

Dust may get in the equipment to cause malfunction. The ejected tray may also become a cause of injuries.



Do not use a cellular phone or pager around the equipment.

Turn off your cellular phone or pager when you use the equipment. Their radio waves may cause the equipment to malfunction.

Rack-mount Model

⚠ CAUTION

Do not attempt to install the server yourself.

To avoid a risk of injuries, users should not attempt to install the equipment into a rack. Installation should be performed by trained maintenance personnel.

< For Maintenance Personnel Only >

Do not remove and carry the equipment with modules mounted.

When you remove this product from the rack and carry it, remove all modules that are mounted first.



Do not install the equipment in such a manner that its weight is imposed on a single place.

To distribute the weight, attach stabilizers or install two or more racks. Otherwise, it may fall down to cause injuries.



Do not assemble parts alone.

It takes at least two people to mount doors and trays to a rack. Otherwise, you may drop some parts to cause a breakage or injuries.



Do not pull a device out of the rack if it is unstable.

Before pulling out a device, make sure that the rack is fixed (by stabilizers or quake-resistant engineering).



Do not leave two or more devices pulled out from the rack.

If you pull out two or more devices the rack may fall down. You can only pull out one device at a time.



Do not install excessive wiring.



To prevent burns, fires, and damage to the equipment, make sure that the rated load of the power branch circuit is not exceeded. For more information on installation and wiring of power-related facilities, contact your electrician or local power company.



Unpackaging

The following section describes necessary information to use the product properly and safely.

Accessories

This product is shipped with various accessories. See the attached list to make sure everything is included and check the individual items. If any component is missing or damaged, contact your sales agent.

- Keep the accessories in a safe place. You will need them when you perform setup, addition of options, or replacement of failed components.
- To check Backup CD-ROM components, see the attached list.
- Be sure to fill out and mail the software registration card that is shipped with the operating system.
- Make backup copies of included floppy disks, if any. Keep the original disks as the master disks; use these copies in operation.
- Improper use of an included floppy disk or CD-ROM may alter your system environment. If you find something unclear, stop using them and contact your sales agent.

Main unit

Confirm the following after you unpack the product.

- If your product has standard configurations, before you set up the main unit, attach optional memory and CPU that you purchased separately. See the separate volume of User's Guide for details.

Chapter 2

About Operating System

This chapter gives essential information on the Linux system supported by the server and how to install it.

Installing Linux for NEC Express5800/ft series

For installing an operating system on NEC Express5800/ft series, use Backup CD-ROM.

IMPORTANT: The NEC Express5800/ft series is a precision instrument. You should ask maintenance personnel to install it.

Before performing the ft series setup, contact your sales agent about the latest release of ft control software.

About OS installation

Read the notes here carefully before installing the operating system.

Operating System Supported by the NEC Express5800/ft series

NEC Express5800/ft series supports the operating system, Linux for NEC Express5800/ft series.

NEC Express5800/ft series does not support any operating systems other than the above.

About Linux for NEC Express5800/ft series

Use the ft series setup program to install Linux for NEC Express5800/ft series. Note the following at installation:

IMPORTANT:

- Complete all the setups such as the memory expansion and the BIOS setting before installing Linux for NEC Express5800/ft series.
 - NEC software package, which is to be purchased separately, is also provided with the documentation for installation. However, see this User's Guide for installation into this server.
 - After completing the ft series setup program, make settings for failure management (e.g., memory dump (debug information) setting) according to Chapter 4.
-

Chapter 3

Installing Server

This chapter describes requirements for using the product properly and safely, the setup procedures to make NEC Express5800/ft series ready for use, and how to connect peripherals.

Installation

This section describes installation of NEC Express5800/ft series.

Tower Model

IMPORTANT: NEC Express5800/ft series is a precision instrument. You should ask maintenance personnel to install it.

Select a suitable site for tower model.

⚠ CAUTION



Observe the following precautions to use the equipment safely. There are risks of a burn, injury, or damage to physical assets. For details, see “Notes for Safe Handling” in Chapter 1.

- Remove all modules before moving the equipment.
- Do not install the equipment in non-designated places.

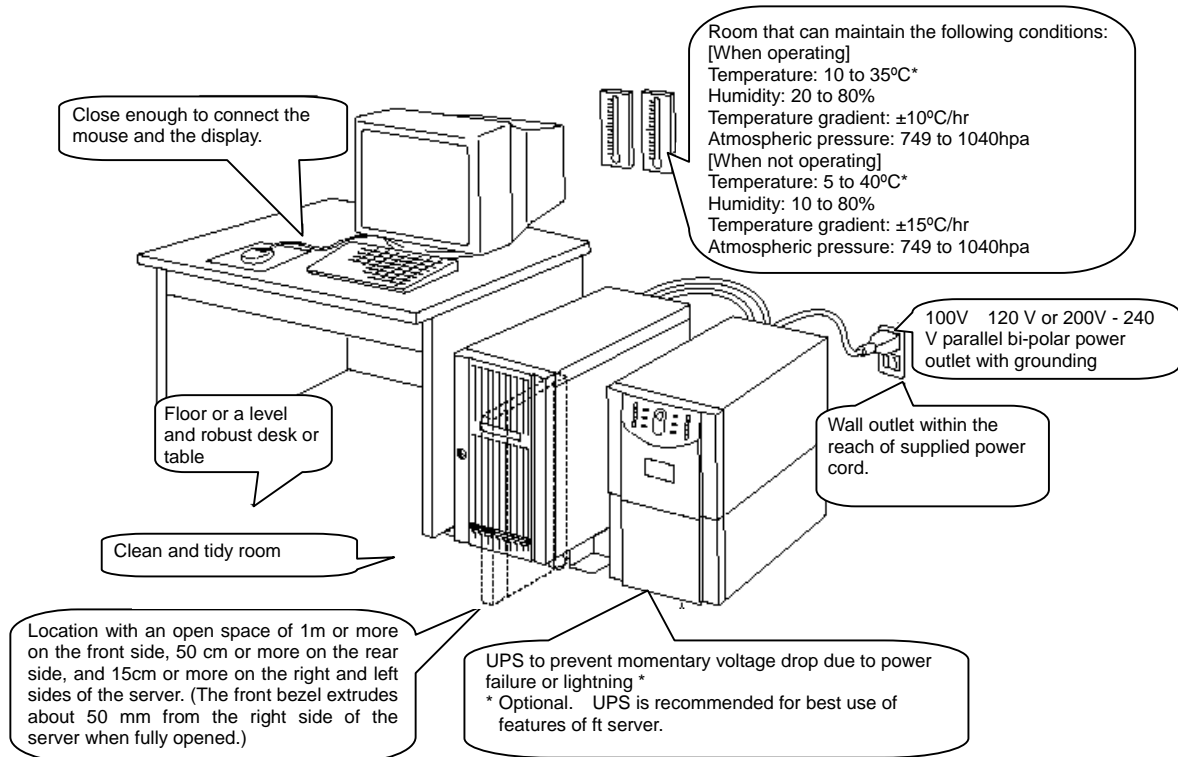

* It is recommendable to use the server in a room where temperature can be kept between 15 and 25°C.

Do not install NEC Express5800/ft series in such places as listed below. Otherwise, the server may malfunction.

- Place where temperatures change widely (near a heater, air conditioner, or refrigerator).
- Place that is subject to intense vibration.
- Place where corrosive gas (sodium chloride, sulfur dioxide, hydrogen sulfide, nitrogen dioxide, or ozone) is generated, or a place that is close to chemicals or exposed to chemicals.
- Place whose floor is covered with non-antistatic carpet.
- Place that may be subject to falling objects.
- Place where you may step or trip on the power cords or interface cables.
- Place that is close to some equipment that generates intense magnetic field (e.g., TV set, radio, broadcasting/communications antenna, power transmission wire, and electromagnetic crane). (If unavoidable, contact your sales agent to request proper shield construction.)
- Place where the power cord of the server must be connected to an AC outlet that shares the outlet of another device with large power consumption.
- Place that is close to some equipment that causes power noises (e.g., sparks caused by power-on/off using a relay). If you must install the server close to such equipment, request your sales agent for separate power cabling or noise filter installation.

It takes at least two people to carry the server; hold it firmly by its bottom and place it slowly on the selected site.

IMPORTANT: Do not hold the front bezel to lift it, or it may become detached and fall down.

After placing the main cabinet, lock its two front casters and screw the attached four stabilizers on the cabinet adjusting their height.

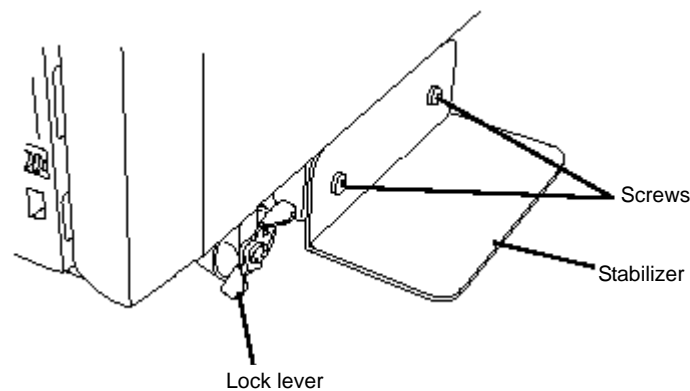

After fastening the main cabinet, open its front bezel to mount the CPU and PCI modules. For details, see the following section “Installation of Rack-mount Model.” Procedures are basically the same for the tower model except that its modules are mounted vertically instead of horizontally.

IMPORTANT: Follow the procedures below to install the CPU and PCI modules. Note the followings before installing them.

- Ensure the main cabinet is immobilized.
 - Place removed modules to the side of the main cabinet. Do not place modules on top of the main cabinet.
 - Be sure to hold the modules tightly, and then mount them slowly and carefully.
 - If you cannot install modules smoothly, remove them and try again.
 - Install the CPU modules in the right two slots, the PCI modules in the left two slots.
 - Perform installation from the left slots.
-

Installation of Rack-mount Model

You can mount NEC Express5800/ft series on a rack that conforms to the EIA standards.

IMPORTANT: NEC Express5800/ft series is a precision instrument. You should ask maintenance personnel to install it.

To install a rack, contact your sales agent or maintenance personnel.

⚠ CAUTION



Do not attempt to install the server.

To avoid the risk of personal injury, users should not attempt to install the server into the rack assembly. The server should be installed in the rack only by trained maintenance personnel.

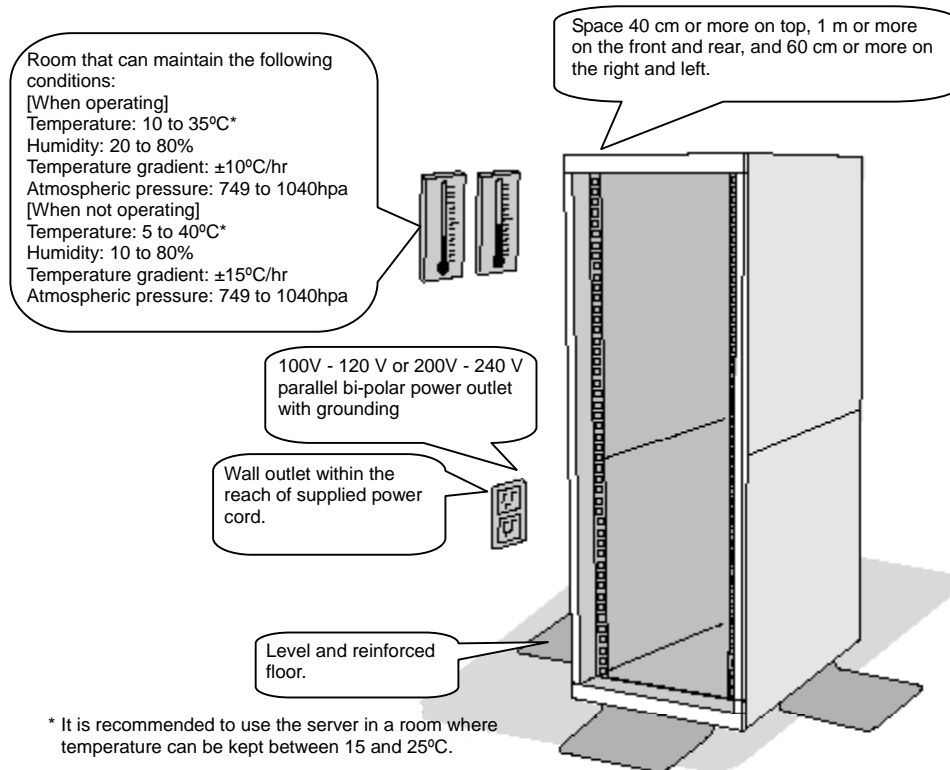

⚠ WARNING



Observe the following precautions to use the server safely. There are risks of a death or serious injury. For details, see “Notes for Safe Handling” in Chapter 1.

- Do not install the equipment in non-designated places.
- Do not connect the ground wire to a gas pipe.

⚠ CAUTION



Observe the following precautions to use the equipment safely. There are risks of a burn, personal injury, or damage to physical assets. For details, see “Notes for Safe Handling” in Chapter 1.

- Do not carry or install the equipment alone.
- Do not install the equipment in such a manner that its weight is imposed on a single place.
- Do not assemble or disassemble parts alone.
- Do not pull a device out of the rack if it is unstable.
- Do not leave two or more devices pulled out from the rack.
- Do not install excessive wiring.

Do not install NEC Express5800/ft series in such places as listed below. Otherwise, the server may malfunction.

- Place where you cannot pull out the components fully.
- Place that cannot sustain the total weight of the rack system.
- Place where you cannot mount stabilizers or where you cannot perform installation without quake-resistant engineering.
- Place whose floor is uneven or inclined.
- Place where temperatures change widely (near a heater, air conditioner, or refrigerator).
- Place that is subject to intense vibration.
- Place where corrosive gas (sodium chloride, sulfur dioxide, hydrogen sulfide, nitrogen dioxide, or ozone) is generated, or a place that is close to chemicals or exposed to chemicals.
- Place whose floor is covered with non-antistatic carpet.
- Place that may be subject to falling objects.
- Place that is close to some equipment that generates intense magnetic field (e.g., TV set, radio, broadcasting/communications antenna, power transmission wire, and electromagnetic crane). (If unavoidable, contact your sales agent to request proper shield construction.)
- Place where the power cord of the server must be connected to an AC outlet that shares the outlet of another device with large power consumption.

- Place that is close to some equipment that causes power noises (e.g., sparks caused by power-on/off using a relay). If you must install the server close to such equipment, request your sales agent for separate power cabling or noise filter installation.



IMPORTANT: Temperature increase inside the rack and airflow



If you install several components or the ventilation isn't good inside the rack, the internal temperature may increase due to heat emitted from the components. When the operating temperatures of NEC Express5800/ft series (10° to 35°C) are exceeded, there is a risk of malfunction. You must take adequate precautions and measures for airflow inside the rack as well as in the room so that the internal temperature can be kept within this range during operation.

Connection

Connect peripheral devices to NEC Express5800/ft series.

The server is provided with connectors for wide variety of peripheral devices on its front and rear. The figure below illustrates available peripheral devices for the server in the standard configuration, and locations of the connectors for the devices. After connecting the peripheral devices, connect the provided power cord with the server, then plug the power cord into the power outlet.

 WARNING	
	<p>Observe the following precautions to use the server safely. There are risks of a death or serious injury. For details, see “Notes for Safe Handling” in Chapter 1.</p> <ul style="list-style-type: none">■ Do not hold the power plug with a wet hand.■ Do not connect the ground wire to a gas pipe.

 CAUTION	
	<p>Observe the following precautions instructions to use the equipment safely. There are risks of a burn, personal injury, or damage to physical assets. For details, see “Notes for Safe Handling” in Chapter 1.</p> <ul style="list-style-type: none">■ Do not plug the power cord in a nonconforming outlet.■ Do not plug too many cords in a single outlet.■ Do not plug the cord insecurely.■ Do not use nonconforming power cords.

IMPORTANT:

- Power off the server before connecting peripheral devices, with the exception of peripherals with USB interface. Connecting a powered peripheral device to the powered server will cause malfunctions and failures.
 - To connect a third-party peripheral device or interface cable to the server, check with your sales agent to see if they are compatible with NEC Express5800/ft series. Some third-party devices may not be used with the server.
 - The total cable length of SCSI device connections is up to 6 m, including the internal SCSI cables.
 - The serial port connectors are reserved for maintenance.
-

A rack-mount model is shown here. As for a tower model, locations of the connectors are same though the orientation of the equipment is different.

IMPORTANT: Space of 1U above the main unit is needed to place the USB floppy disk drive on the main unit for a rack-mount model. For a tower model, place it on the main.

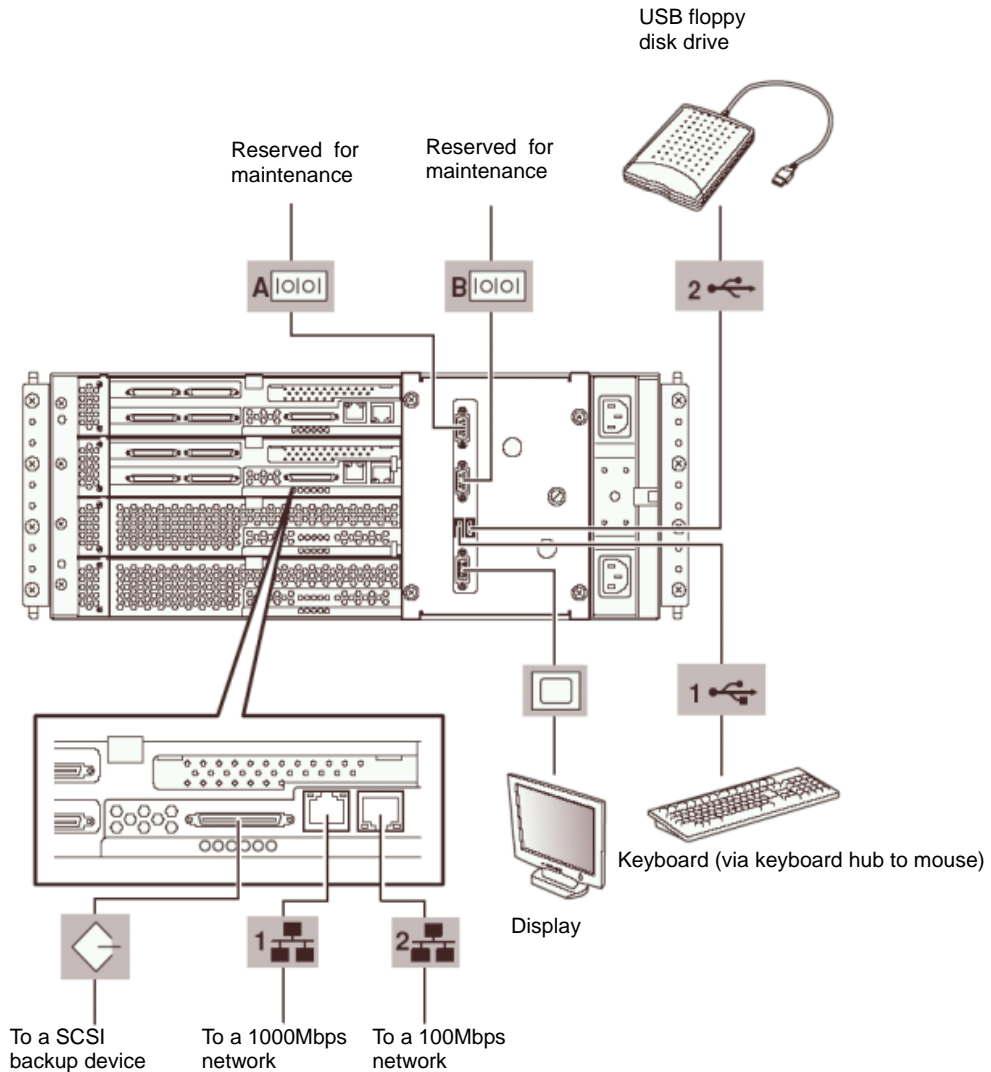

IMPORTANT: Connection of optional devices

In the case of standard configuration, you need to complete setup of the operating system before mounting optional PCI cards or hard disks that you purchased separately.

After connecting cables to PCI modules, secure them with the cable ties.

When completing connection to peripheral equipment, connect the two provided power cords to the server. After that, secure the cables with the cable tie provided in the server.

Connect the plug at the other end of the power cord to a wall outlet with parallel double-pole grounds provided or to an uninterruptible power supply (UPS).

To use the functions of the server, you should connect the server to the UPS.

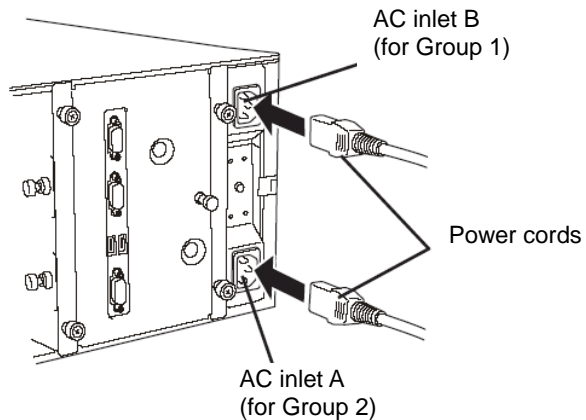

<Example>

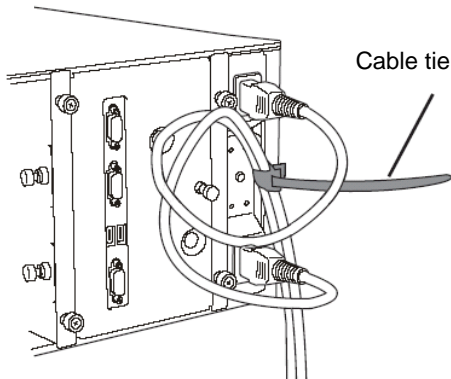

IMPORTANT:

- Be sure to use both of the power cords to use fault tolerant functions.
 - If both PCI modules are mounted, the one you plug in first will become the primary module. The AC inlet B is used for Group 1; the AC inlet A is for Group 2.
 - The module whose POWER switch LED is on is the primary.
-

To connect the power cord from the server to an uninterruptible power supply (UPS), use service outlets on the rear of the UPS.

The UPS service outlets are categorized into two groups: SWITCH OUT and UN-SWITCH OUT. (They may be called "OUTPUT1" and "OUTPUT2".)

For constant power supply, connect the power cord to a UN-SWITCH OUT outlet. (Connect the modem that is in service for 24 hours to this outlet.)

When the power cord from the server is connected to a UPS, change the BIOS setup of the server to link with power supply from the UPS.

Select [AC-LINK] from [System Hardware] on the BIOS setup utility and change parameters. See the separate volume of User's Guide for details.

<Example>

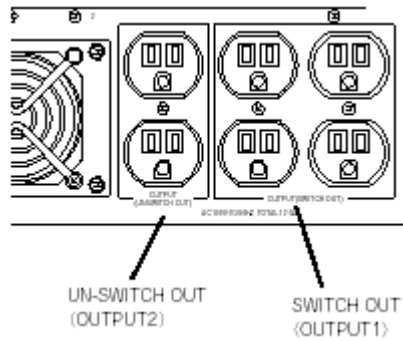

This page is intentionally left blank.

Chapter 4

Linux Setup

This chapter describes procedures for setup to power on the NEC Express5800/ft series for the first time, installation of Linux, setup of dual configuration of LAN cards, setup of dual disk configuration and so on.

Setup Flow

The following flow-chart illustrates the flow of the setup procedures for the server.

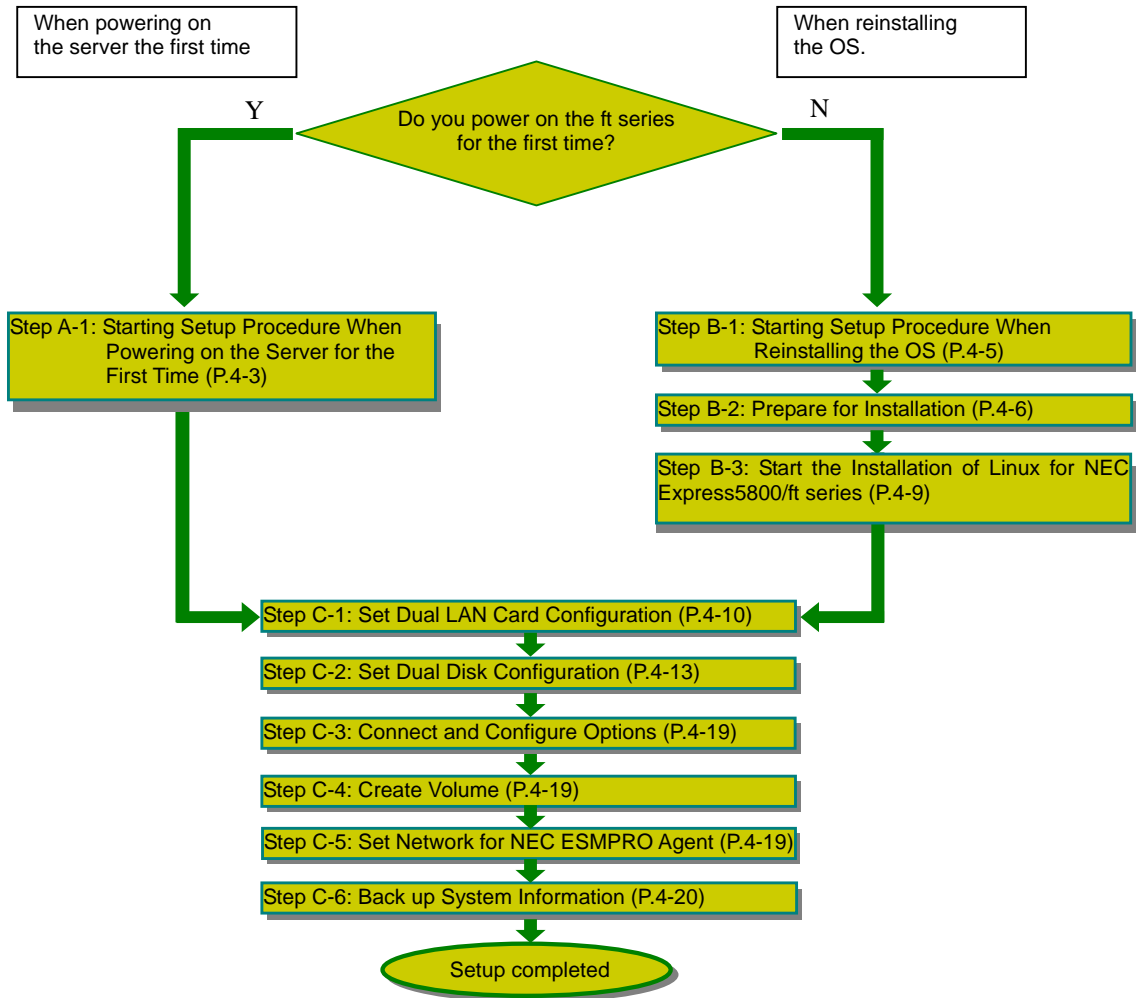

Setup Procedure When Powering on the NEC Express5800/ft series for the First Time

Follow the procedure below to set up the server for the first time after you purchased.

Step A-1: Starting Setup Procedure When Powering on the Server for the First Time

The following explains the initial setup procedure of the NEC Express5800/ft series after you purchased.

You need to prepare the following before starting setup.

- User's Guide (Setup) (this manual)
- User's Guide

CHECK: You don't need to use any media (e.g., CD-ROM).

IMPORTANT:

- You cannot set up the NEC Express5800/ft series properly using procedures other than the one described on this manual.
 - The CPU module Status LED 1 and the PCI module Status LED 1 illuminate red during setup. It does not indicate a malfunction of the module. When the setup has completed and each module is duplicated properly, the CPU module Status LED 1 and the PCI module Status LED 1 go out and the CPU module Status LED 2 and the PCI module Status LED 2 illuminate green. For details of the indications of module's Status LEDs, see "LEDs" on the separate volume of User's Guide.
 - The preinstalled OS requires setting of dual LAN card configuration. Make sure to perform the setting on step 5.
-

1. Power on the server after the hardware setup has completed.

The preinstalled Linux for NEC Express5800/ft series will start.

2. Enter a login name.

When the startup is completed, the login prompt, "localhost login:" will be displayed. Enter "root", and then press **Enter**.

3. Enter the password.

"Password:" will be displayed. Enter the password provided on the "Password of 'root' user" packaged with the backup CD-ROM, and then press **Enter**. The password is case-sensitive.

If the message "Login incorrect" appears and the system waits for the user to enter the password again, the login name or the password was incorrect. Enter the login name and the password again.

4. Change the root password.

Change the password using `passwd` command.

5. Set LAN configuration.

See “Step C-1: Set Dual LAN Card Configuration” (4-10) and perform the setup.

6. Connect and setup the optional devices.

If there are optional PCI boards and peripheral devices which have been purchased separately, power off the server and then follow the instructions of “PCI board” in the separate volume of User’s Guide and the manuals of devices. If you added a LAN card or a disk to the server, you need to set dual configuration. For details, see “Step C-1: Set Dual LAN Card Configuration” (4-10) and “Step C-2: Set Dual Disk Configuration” (4-13).

Setup is now completed.

To perform the setup again, see “Setup Procedure When Reinstalling the OS” (4-5).

Setup Procedure When Reinstalling the OS

You can set up the NEC Express5800/ft series again using a backup CD-ROM.

IMPORTANT:

- The NEC Express5800/ft series is a precision instrument. Ask maintenance personnel with technical knowledge to install it.
 - When you power on the NEC Express5800/ft series for the first time after you purchased, refer to “Setup Procedure When Powering on the NEC Express5800/ft series for the First Time” (4-3) to set up.
-

The following is the procedure to reinstall the OS.

Step B-1: Starting Setup Procedure When Reinstalling the OS

The following explains the reinstallation procedure of the OS.

You need the following to install Linux for NEC Express5800/ft series.

- Linux for NEC Express5800/ft series Back Up CD-ROM 1
- Linux for NEC Express5800/ft series Back Up CD-ROM 2
- “Password of 'root' user” leaflet
- User’s Guide (Setup) (this manual)
- User’s Guide

IMPORTANT: For the latest release of Linux for NEC Express5800/ft series software, ask your sales agent.

Step B-2: Prepare for Installation

Before starting Linux for NEC Express5800/ft series installation, be sure to do the following. If these preparations are not performed, setup cannot be performed properly.

Prepare NEC Express5800/ft series

With the power of NEC Express5800/ft series off, follow the steps below:

1. Prepare NEC Express5800/ft series.

Perform the following preparations.

- Remove all optional PCI boards and peripheral devices.
- Mount the PCI modules (for Group1/for Group2), and CPU modules (for Group1/for Group2).
- Insert one hard disk to the Slot1 of each PCI module (for Group1/Group2).
- Remove all LAN cables.

2. Make the PCI module for Group1 primary.

The location of the parts required for operation and confirmation are shown below.

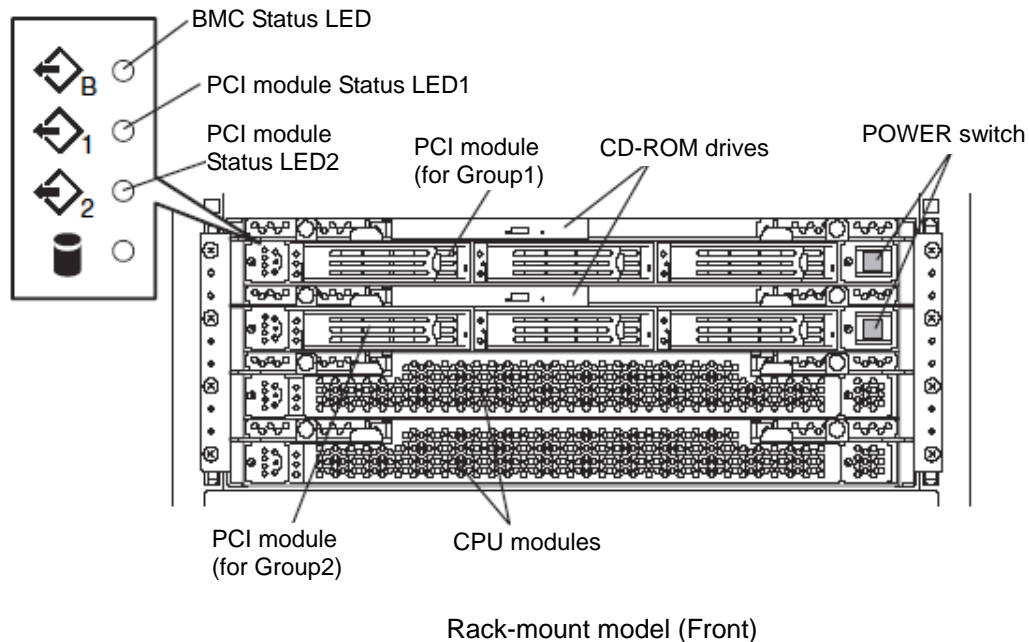

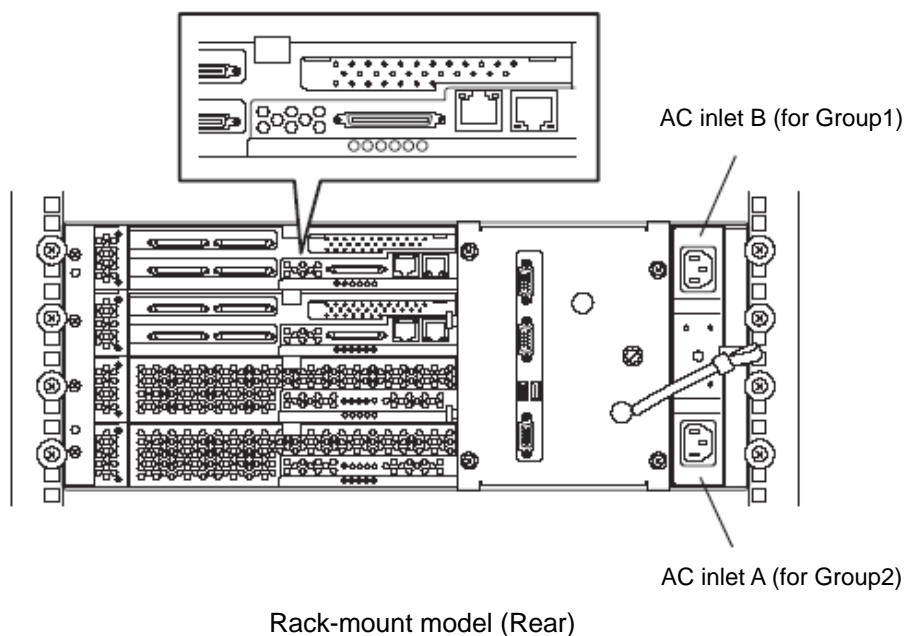

<When the AC power is off (The power cords are not plugged into the outlet)>

Connect the power cords to NEC Express5800/ft series in the following order:

- (1) Connect the power cord to the AC inlet B (for Group1)
- (2) Connect the power cord to the AC inlet A (for Group2)
- (3) Confirm that the POWER switch of the PCI module for Group1 is illuminated.
- (4) Make sure that the two BMC Status LEDs for PCI modules (for Group1/for Group2) are turned off.

IMPORTANT: If the BMC Status LED is red and blinking, do not start installing Linux for NEC Express5800/ft series. Otherwise the setup may not be performed properly.

Preparation is now completed. Start the installation of Linux for NEC Express5800/ft series.

<When the AC power is on (The power cord is plugged to the wall outlet and the main unit's power is off)>

- (1) Check the LED of the PCI module's POWER switch.
 - If the PCI module for Group1's POWER switch is lit, the PCI module for Group1 is primary. Preparations are complete. Start the installation of Linux for NEC Express5800/ft series.
 - If the PCI module for Group2's POWER switch is lit, the PCI module for Group1 is secondary. Continue to (2). Make PCI module for Group1 the primary module.

- (2) Make sure that the two BMC Status LEDs of the PCI modules (for Group1/for Group2) are turned off.

IMPORTANT: While the BMC Status LED is red and blinking, do not perform (3) and on. Otherwise the BMC firmware may become damaged.

- (3) Remove the power cord of the AC inlet A (for Group2).
- (4) Check that the POWER switch of the PCI module for Group1 is turned on.
- (5) Connect the power cord of the AC inlet A (for Group2).
- (6) Make sure that two BMC Status LED for PCI modules (for Group 1/for Group 2) are turned off.

IMPORTANT: If the BMC Status LED is red and blinking, do not start installing Linux for NEC Express5800/ft series. Otherwise the setup may not be done properly.

Preparation is now completed. Start the installation of Linux for NEC Express5800/ft series.

Step B-3: Start the Installation of Linux for NEC Express5800/ft series

Follow the steps below to install Linux for NEC Express5800/ft series.

IMPORTANT:

The CPU module Status LED 1 and the PCI module Status LED 1 illuminate red during setup. It does not indicate a malfunction of the module. When the setup has completed and each module is duplicated properly, the CPU module Status LED 1 and the PCI module Status LED 1 go out and the CPU module Status LED 2 and the PCI module Status LED 2 illuminate green. For details of the indication of module's Status LEDs, see "LEDs" on the separate volume of User's Guide.

1. Turn on the NEC Express5800/ft series.
2. Insert the "Linux for NEC Express5800/ft series Back Up CD-ROM 1" CD-ROM into the CD-ROM drive of the NEC Express5800/ft series.

IMPORTANT: For the installation of Linux for NEC Express5800/ft series, insert the CD-ROM into the PCI module for Group1's CD-ROM drive.

3. When having inserted the CD-ROM correctly, reset the system (press **Ctrl, Alt** and **Delete** together), or turn the power off and then turn it on to restart the NEC Express5800/ft series.

The installation will be started. After a while, the message "Change CDRom" will appear.

4. Follow the message and change the CD-ROM to the Back Up CD-ROM 2.
5. Press **Enter**.

When the installation has completed properly after a while, a message "Complete" will appear.

6. Press **Enter**.

The system will restart automatically and the Back Up CD-ROM 2 will be ejected. Take out the CD-ROM.

The root password after the restart is the one which was set to the server when you purchased it. For the preset password, see "Password of 'root' user" packaged with the backup CD-ROMs. For security, change the password after logging in as a root user.

IMPORTANT:

After the system restarted, the status of the two disks installed for constructing RAID become "RESYNCING" or "RECOVERY" for a while. Do not stop or restart the system while the status of "RESYNCING" or "RECOVERY" continues. You can check the status of RAID by using `ftdiskadm`.

The installation of Linux for NEC Express5800/ft series is now completed.

Step C-1: Set Dual LAN Card Configuration

LAN configuration is not set to Linux for NEC Express5800/ft series preinstalled to the hard disk drive of the NEC Express5800/ft series, or after Linux for NEC Express5800/ft series is reinstalled. If you use a network, you need to set dual LAN card configuration.

The NEC Express5800/ft series builds a dual LAN card configuration by using “Stratus emb-82559 10/100 Enet Adapter” (100Base) and “Stratus emb-82544GC Copper Gigabit Adapter” (1000Base) mounted as standard on the PCI module.

The following is a description of setting 100Base built-in LAN card.

For the setting of 1000Base built-in LAN card, perform the following by changing “7” used for slots and commands on the description to “4”.

TIPS: To set dual LAN card configuration, you need to log in as a root user.

1. Log in to the system as a root user.
2. Execute the following command to check if the indication of LAN card appears on the slot 7.

```
>vndctl status
```

```
-Virtual Network Status-
virtual status ipconf slot real(s)

slot    real    status link
1  left  -
   right -
2  left  -
   right -
3  left  -
   right -
4  left  gb01.03.0 -
   right gb40.03.0 -
5  left  -
   right -
6  left  -
   right -
7  left  epro01.06
   right epro40.06
```

3. Execute the following command to add the LAN card of the slot 7 to the VND list.

```
>vndctl add 7
```

- Use the following command to check the status of LAN card.

```
>vndctl status 7
```

You can check the status of the slot 7 using vndctl.

```
--Virtual Network Status--
virtual status ipconf slot real(s)
ha0    OKAY    no    7    *epro01.06 epro40.06
      Link encap:Ethernet HWaddr 00:30:13:F1:E9:7D
      BROADCAST MASTER MULTICAST MTU:1500 Metric:1
      RX packets:0 errors:0 dropped:0 overruns:0 frame:0
      TX packets:0 errors:0 dropped:0 overruns:0 carrier:0
      collisions:0 txqueuelen:0
      RX bytes:0 (0.0 b) TX bytes:0 (0.0 b)

slot   real    status  link
7      left   epro01.06 DOWN
      Link encap:Ethernet HWaddr 00:30:13:F1:E9:7D
      BROADCAST SLAVE MTU:1500 Metric:1
      RX packets:12242 errors:0 dropped:0 overruns:0 frame:0
      TX packets:129 errors:0 dropped:0 overruns:0 carrier:0
      collisions:0 txqueuelen:100
      RX bytes:946021 (923.8 Kb) TX bytes:6876 (6.7 Kb)
      Interrupt:47 Base address:0xb000

      right epro40.06 DOWN
      Link encap:Ethernet HWaddr 00:30:13:F1:E9:7D
      BROADCAST SLAVE MTU:1500 Metric:1
      RX packets:125 errors:0 dropped:0 overruns:0 frame:0
      TX packets:0 errors:0 dropped:0 overruns:0 carrier:0
      collisions:0 txqueuelen:100
      RX bytes:8928 (8.7 Kb) TX bytes:0 (0.0 b)
      Interrupt:19 Base address:0xd000
```

“ha0” indicates the interface name (ha0) which is used to set dual configuration to the two LAN cards and then virtually treat them as one LAN card, and their setting values. The descriptions under “ha0” are values set for two LAN cards.

- Use the following command to make settings of the dual LAN card configuration of the slot 7.

```
>vndctl config 7
```

The screen will be switched to the entry screen. (netconfig command is being executed.)

The message “Would you like to set up networking?” will appear. Click “Yes” to continue. Specify whether you use DHCP or not, and IP addresses, etc., depending on the operating environment.

- Use the following command to activate the dual LAN card configuration of the slot 7.

```
>vndctl up 7
```

7. Check the status.

>vndctl status

```
-Virtual Network Status-
virtual status ipconf slot real(s)
ha0 OKAY yes 7 *epro01.06 epro40.06

slot    real    status link
1 left   -
      right -
2 left   -
      right -
3 left   -
      right -
4 left   gb01.03.0 -
      right gb40.03.0 -
5 left   -
      right -
6 left   -
      right -
7 left   epro01.06 UP LINK
      right epro40.06 UP LINK
```

Dual LAN card configuration has completed when the screen displays the status is “UP”, and the link is “LINK” (with LAN cable connected) as shown above.

8. Execute the following command to check whether the settings such as IP addresses are set correctly.

>vndctl ipconf 7

```
DEVICE=ha0
ONBOOT=yes
BOOTPRONTO=static
IPADDR=192.168.99.10
NETMASK=255.255.255.0
GATEWAY=192.168.99.1
```

Step C-2: Set Dual Disk Configuration

If you are performing “Setup Procedure When Powering on the NEC Express5800/ft series for the First Time”, go to “Step C-3: Connect and Configure Options” (4-19).

At the time of shipment of the NEC Express5800/ft series, the following settings have been already made so that you can use the server immediately after the purchase.

NEC Express5800/ft series secures data by making disks to RAID configuration.

NEC Express 5800/ft series is set up to automatically set dual configuration of the built-in disk for boot in either status; when you purchased the server, or immediately after Linux for NEC Express5800/ft series was installed to the server. However, make sure to check the status of dual disk configuration to prevent unexpected problems. If needed, set dual disk configuration.

IMPORTANT: If you are performing “Setup Procedure When Powering on the NEC Express5800/ft series for the First Time”, this step is not needed as the dual disk configuration has already been configured. Go to “Step C-3: Connect and Configure Options” (4-19).

TIPS: To set dual disk configuration, you need to log in as a root user.

IMPORTANT:

- Make sure to set RAID not only when installing an operating system but also when adding disks or reconstructing RAID.
 - When adding disks or reconstructing RAID, the status of each disk becomes “RESYNCING” or “RECOVERY”. Do not remove disks, turn off the power, or restart the system during this status. Wait until the status “RESYNCING” or “RECOVERY” is finished. You can check the status of RAID using `ftdiskadm` described later.
-

Disk management tool (ftdiskadm)

You can check the status of the integrated SCSI disk and set the RAID configuration safely by using disk management tool (ftdiskadm).

By using ftdiskadm, you can;

- Check the status of the entire built-in disks
- Check the status of RAID of the built-in disks
- Recover RAID of the built-in disk
- Extend the built-in disk
- Detach the built-in disk

<Example>

```
# ftdiskadm
Command action
 1 => SCSI
 2 => RAID
 3 => Environment
 9 Quit

Command: 2

Command action
 1 Status(Raid)
 2 Status(All Disks)
 3 Repair Disk
 4 New Disks
 5 Remove Half Disk
 6 Remove Full Disks
 9 <= RETURN

Command:
...
```

Check the status of the SCSI disk

Check the status of the SCSI disk using `ftdiskadm` command.

The following is an example of the display when “Status(All Disks)” of “=> RAID” is executed.

<Example>

```
[SCSI DISK STATUS]
-- BUS --
bus pci(haddr)
 0 01:05.00(10.5.0)
 1 40:05.00(11.5.0)
 2 01:02.00(10.2.0)
 3 40:02.00(11.2.0)

-- SYSTEM --
slot name use serial          tuple      path
 1 sda  7 #3JA73L5R00007430B065  b0t0l0    d10h0c0t0l0
 2 -
 3 -
 4 sdd  7 #3JA73HYE000074298UHV   b1t0l0    d11h1c0t0l0
 5 -
 6 -

-- EXTENSION --
name use serial          tuple      path
sdh  0 #0000924310220000  b3t0l0    d0h3c0t0l0
     0 #0000924310220000  b2t0l0    d0h2c0t0l0
sdi  0 #0000924310220001  b3t0l0    d0h3c0t0l1
     0 #0000924310220001  b2t0l0    d0h2c0t0l1
```

“--BUS--” part is the information of a SCSI BUS.

“bus” indicates <SCSI_BUS_number>, “pci” indicates <PCI_BUS number>:<PCI_SLOT_number>.<CHANNEL_number>, and “(haddr)” indicates <hardware_address>.

“--SYSTEM--” part is the information of a standard integrated SCSI disk, and “--EXTENSION--” part is a SCSI disk number connected to the SCSI board extended on the PCI slot.

slot is <SCSI_disk_slot_number>, name is <device_name>, use is <current_usage_count>, serial is #<serial_number>, tuple is <SCSI_tuple>, and path is <SCS_path>.

<SCSI_tuple>=b<BUS_number>t<TARGET_number>|<LUN>

<SCSI_path>=d<DOMAIN_number>h<HOST_number>c<CHANNEL_number>t<TARGET_number>|<LUN>

The first tuple and path displayed are active.

Check the status of RAID of the disk on “Status(Raid)”.

1. Log in as a root user.
2. Execute the following command to start `ftdiskadm`.

```
>ftdiskadm
```
3. Enter “2” and then press **Enter**.

The RAID menu will be displayed.

4. Enter “1” and then press **Enter**.

“Status (Raid)” (the disks’ current status of RAID) will be displayed.

(Display example of the RAID status)

[Status(Raid)]					
name	partition	label	status	member	
md0	/boot	/boot	DUPLEX	(1)sda1	(4)sdd1
md1	/user	/usr	DUPLEX	(1)sda5	(4)sdd5
md2	/home	/home	DUPLEX	(1)sda10	(4)sdd10
md3	/var	/var	DUPLEX	(1)sda6	(4)sdd6
md4	/	/	DUPLEX	(1)sda8	(4)sdd8
md5	/tmp	/tmp	DUPLEX	(1)sda9	(4)sdd9
md6	swap		DUPLEX	(1)sda7	(4)sdd7

“name” is the name of a software RAID device.

“partition” is a mount point or a swap. If this field is blank, RAID is configured but not mounted as a file system.

“member” is the information of the member configuring RAID. The information will be displayed in the following format for the number of members.

(Slot number) name

If the status is error, (F) is marked on the right. In such case, you need to correct RAID. status indicates the status of RAID. The following are the descriptions of the status messages.

DUPLEX	: Normal status.
RESYNCING (X.X%)	: Being synchronized. When completed, it becomes DUPLEX.
RECOVERY (X.X%)	: Being recovered. The members with “-” mark on the member field have not been built yet.
SIMPLEX	: Only one side of RAID is built. If two members are displayed on the member field, the member with “-” mark is on standby before RECOVERY status. If only one member is displayed, recovery is required.
ERROR	: ERROR status. The members of RAID do not exist.

Start the SCSI disk

To start the SCSI disk manually, use `ftdiskadm`.

The following is an example of procedure to start SCSI disk using `ftdiskadm`.

<Example>

```

Command action
 1 => SCSI
 2 => RAID
 3 => Environment
 9 Quit

Command: 1

Command action
 1 Status(All Disks)
 2 Status(System Disks)
 3 Status(Extended Disks)
 4 Bring Up
 5 Bring Down
 9 <= RETURN

Command: 4

[Bring Up]
* Which disk(s)? ['?' for help] => (10.1)t0!* (Note 1)
ftdisk: ERROR(1): Bringing up reached timeout! (Note 2)

<<<Check the status of SCSI disk>>>

```

Note 1: You can list the disk specification methods by entering “?”.

“*” can be used in the TARGET section and LUN section, and the range will be from 0 to the sum of the maximum number succeeded to start and the number of overrun. The number of overrun is the value of the environment variable `FTDISKADM_TID_OVERRUN` for TARGET, and `FTDISKADM_LUN_OVERRUN` for LUN. It can be checked/modified on “Environment” of each menu. In addition, you can put the numbers inside “[]” (e.g., [`<num1>`,`<num2>`]), or specify the range of the numbers (e.g., [`<num3>`,`<num5>`]).

Note 2: If the values of overrun are 1 or more, some may fail according to the value.

Check the status for the command execution number.

Stop the SCSI disk

To stop the SCSI disk manually, use `ftdiskadm`.

The following is an example of procedure to stop the SCSI disk using `ftdiskadm`.

<Example>

```
Command action
 1 => SCSI
 2 => RAID
 3 => Environment
 9 Quit

Command: 1

Command action
 1 Status(All Disks)
 2 Status(System Disks)
 3 Status(Extended Disks)
 4 Bring Up
 5 Bring Down
 9 <= RETURN

Command: 5

[Bring Down]
* Which disk(s)? ['?' for help] => (10.1)t0l5 (Note 1)
* Bringing down: '(10.1)t0l5 [d0h2c0tl5]' [y/n]

<<<Check the status of SCSI disk>>>
```

Note 1: You can list the disk specification methods by entering “?”.

“*” can be used in the TARGET section, LUN section, serial number, device name and it fits to all candidates. In addition, you can put the numbers inside “[]” (e.g., [`<num1>`,`<num2>`]), or specify the range of the numbers (e.g., [`<num3>`,`<num5>`]).

Step C-3: Connect and Configure Options

When there are option PCI boards or peripheral devices to connect to the main unit, power off the main unit. Then, for connecting them, follow the instructions in “PCI board” in the separate volume of the User’s Guide and the manual of the devices.

TIPS: If LAN cards or disks are added, you need to set dual configurations. For details, see “Step C-1: Set Dual LAN Card Configuration” (page 4-10) and “Step C-4: Create Volume” (page 4-19).

Step C-4: Create Volume

If you create a new volume on the expanded internal disk, see “System Upgrade” in the separate volume of the User’s Guide and configure RAID.

Step C-5: Set Network for NEC ESMPRO Agent

NEC ESMPRO Agent is required for continuous operation of the NEC Express5800/ft series, and it is preinstalled. Also, it will be installed automatically when reinstalling the OS by using Linux for NEC Express5800/ft series Back Up CD-ROM.

To run NEC ESMPRO Agent, you need to make settings of the SNMP. For details and methods of the settings, see from “2. Environment settings of snmpd” to “5. Setting firewall” on “NEC ESMPRO Agent” of “Installing Management Utility”.

Step C-6: Back up System Information

After setting up the system, back up the system information using the Off-line Maintenance Utility.

Without backup for system information, the information and settings that are specific to your server cannot be restored if the server is repaired. Take the following steps to make a backup copy of the system information:

1. Get a 3.5-inch floppy disk.
2. Insert the "NEC EXPRESSBUILDER" CD-ROM into the CD-ROM drive of the server, and restart the system.

NEC EXPRESSBUILDER is activated and [NEC EXPRESSBUILDER Top Menu] is displayed.

3. Select [Off-line Maintenance Utility] from [Tools].
4. Select [Save System NVRAM/ROM Data] from [System Information Management].

Follow the instructions you see on the screen.

The ft series setup is now completed.

Chapter 5

Procedures after Completion of Installation

This chapter describes what you do after installation including setup for failure management, how you install management utilities, how you back up system information, and setup of PCs on the network. You may need to confirm these procedures while the system is running.

Installing Management Utilities

The “NEC EXPRESSBUILDER” CD-ROM, “Linux for NEC Express5800/ft series Back Up CD-ROM 1”, “Linux for NEC Express5800/ft series Back Up CD-ROM 2” are shipped with the NEC Express5800/ft series.

“Linux for NEC Express5800/ft series Back Up CD-ROM 2” contains “NEC ESMPRO Agent” for monitoring the NEC Express5800/ft series, and “NEC EXPRESSBUILDER” contains “NEC ESMPRO Manager” for managing the NEC Express5800 series. Install and setup these utilities in the NEC Express5800/ft series or the computer (management PC) that manages the NEC Express5800/ft series.

NEC ESMPRO Agent

NEC ESMPRO Agent is a utility to monitor the operating status, the configuration information, the failure occurrence status of hardware and software on the NEC Express5800/ft series. When it detects some problems, it sends messages to the computer in which the NEC ESMPRO Manager is installed.

NEC ESMPRO Agent is already installed to the hard disk drive of the server at the time of shipment. Also, it is automatically installed when Linux for NEC Express5800/ft series is installed. However, you still need to set up according to your environment for operating NEC ESMPRO Agent. See “Preparation before Setup” described later to set up.

IMPORTANT: Make sure that NEC ESMPRO Agent is installed because it is indispensable for continuous operation of NEC Express5800/ft series.

Operation Environment

NEC ESMPRO Agent can be operated in the hardware and software environments shown below.

- Hardware
 - Installation system NEC Express5800/ft series
- Software

The following packages are required.

- ucd-snmp
- ucd-snmp-devel
- ucd-snmp-utils
- newt
- newt-devel
- portmap

- slang
- slang-devel

Preparation before Setup

Be sure to read the following before system installation or setup.

To operate NEC ESMPRO Agent, each service must be installed appropriately and must be operating.

1. Check necessary packages

The following packages are needed to use NEC ESMPRO Agent.

If there are any packages which are not installed, install them.

- ucd-snmp
- ucd-snmp-devel
- ucd-snmp-utils
- newt
- newt-devel
- portmap
- slang
- slang-devel

2. Environment settings of snmpd

Modify the environment setting file of snmpd (/etc/snmpd.conf) to set a community right to more than "READ WRITE".

Correct the environment setting using vi command, etc., referring to the following.

For details of the settings, refer to the online help of snmpd.

```
###
```

```
# Third, create a view for us to let the group have rights to:
```

```
#      name    incl/excl  subtree  mask(optional)
view   all      included   .1       80
```

```
###
```

```
# Finally, great the group read-only access to the systemview view.
```

```
#      group    context    sec.model sec.level  prefix read    write notif
access notConfigGroup ""         any        noauth exact  all    all
none
```

3. Start setting of snmpd

Set snmpd to start automatically.

4. Start setting of portmap

Set portmap to start automatically.

5. Setting firewall

When monitoring from the NEC ESMPRO Manager, use the following port.

If you set the firewall on your environment, set the access permission to the following port.

```
snmp      161/udp
snmp-trap 162/udp
```

Installation procedure

TIPS: The NEC ESMPRO Agent is already installed to the hard disk drive of the server at the time of shipment. Also, it is automatically installed when Linux for NEC Express5800/ft series is installed.

1. Log in to the system as a root user.
2. Set the Back Up CD-ROM2 to the CD-ROM drive.
3. Enter the following command to mount the CD-ROM.

In this example, the mount point is assumed to be "mnt/cdrom".

```
# mount /mnt/cdrom
```

4. Move to the directory where the package of the NEC ESMPRO Agent is stored.

```
# cd /mnt/cdrom/nec/esmpro_sa
```

5. Enter the following commands to install the package:

```
# rpm -ivh nechwid-3.00.00-1.i386.rpm
```

```
# rpm -ivh Esmpro-common-dat-4.0.4-1.i386.rpm
```

```
# rpm -ivh Esmpro-common-bin-4.0.4-1.i386.rpm
```

```
# rpm -ivh Esmpro-type2-dat-4.0.4-1.i386.rpm --nodeps
```

```
# rpm -ivh Esmpro-type2-bin-4.0.4-1.i386.rpm
```

```
# rpm -ivh Esmpro-ft-4.0.4-1.i386.rpm
```

Uninstallation procedure

1. Log in to the system as a root user.
2. Enter the following commands to uninstall the package:

```
# rpm -e Esmpro-ft
```

```
# rpm -e Esmpro-type2-bin
```

```
# rpm -e Esmpro-type2-dat
```

```
# rpm -e Esmpro-common-bin
```

```
# rpm -e Esmpro-common-dat
```

```
# rpm -e nechwid
```

Setup of NEC ESMPRO Agent

Follow the instructions below to setup the NEC ESMPRO Agent.

1. Log in the system as a root user.
2. Move to the directory where the NEC ESMPRO Agent is installed.

```
cd /opt/nec/esmpro_sa
```

3. Move to the directory where the control panel is stored.

```
cd bin
```

4. Start the control panel.

`./ESMagentconf`

The screen of the control panel will appear.

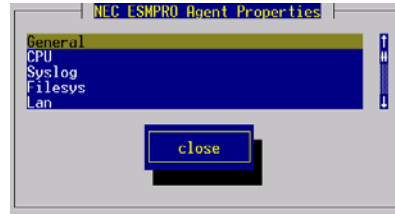

TIPS:

For details of the setting, refer to the User's Guide of the NEC ESMPRO Manager.

The User's Guide is stored on the following place of the Back Up CD-ROM 2.

`/nec/esmpro_sa/doc/users.pdf`

Report Setting

To report from the NEC ESMPRO Agent to the NEC ESMPRO Manager, you need to set the method of report.

Setting of Manager (SNMP)

1. Log in the system as a root user.
2. Move to the directory where the NEC ESMPRO Agent is installed.
`cd /opt/nec/esmpro_sa`
3. Move to the directory where the Report Setting tool is stored.
`cd bin`
4. Start the Report Setting tool.
`./ESMamsadm`

The [Report Setting] screen will appear.

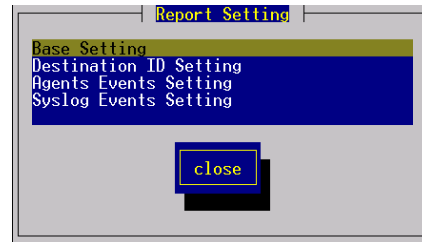

5. Select [Base Setting].

The [Base Setting] screen will appear.

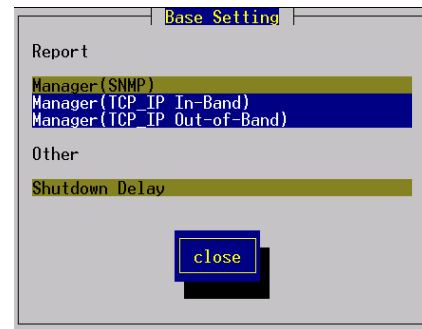

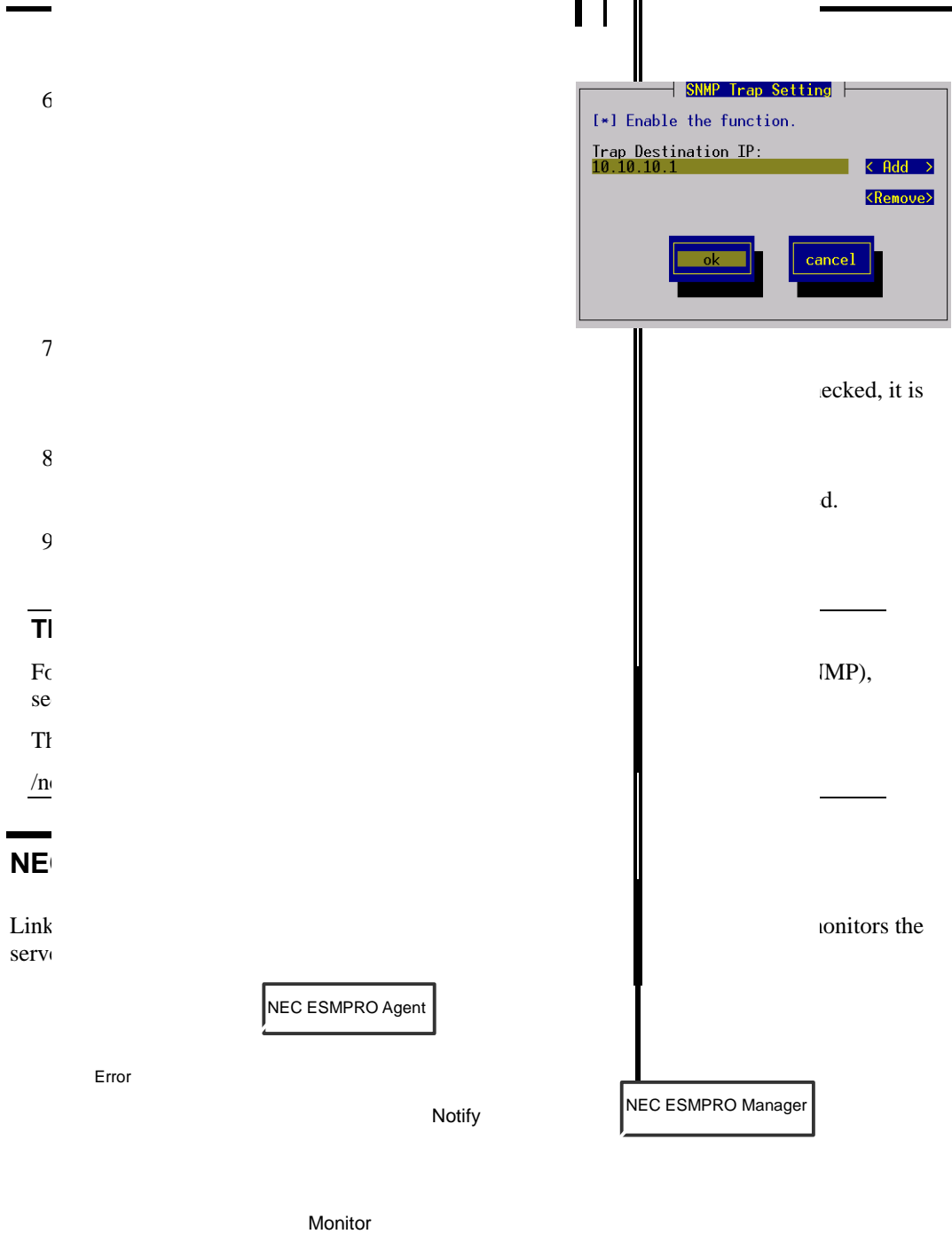

When a failing module in the server is to be replaced, NEC ESMPRO Manager enables logical module disconnection from the server and logical installation after module replacement.

For the installation of NEC ESMPRO Manager and notes on the operation, see the separate volume of User's Guide.

NEC MWA

NEC MWA is an application that enables remote management of the server (this product) through a management PC over the network. (A management PC is a computer running NEC ESMPRO Manager.)

To establish communication between the server and the management PC, install “NEC MWA” in the management PC. For NEC MWA, see the separate volume of User’s Guide.

System Requirement

The hardware and software environment in which NEC MWA runs is:

- Management PC (to install NEC MWA)
NEC MWA runs on a computer where Windows is operated. For more information, see “MWA First Step Guide”.
- The servers that can be maintained remotely by NEC MWA
Servers which the User’s Guide provided with NEC Express5800/ft series include descriptions of NEC MWA. The servers are equipped with RomPilot or BMC. This product has BMC (IPMI1.0) and RomPilot.

Installation of NEC MWA Manager

To manage this product using NEC MWA, install NEC MWA Manager on the management PC. Use the “NEC EXPRESSBUILDER” CD-ROM to install NEC MWA Manager.

1. Start up Windows.

TIPS: For OS compatibility, see “MWA First Step Guide”.
CR-ROM drive: \mwa\doc\jp\mwa_fsg.pdf

2. Insert the “NEC EXPRESSBUILDER” CD-ROM into the CD-ROM drive.

Master Control Menu of NEC EXPRESSBUILDER will be automatically displayed.

3. Click [Setup], then [MWA].

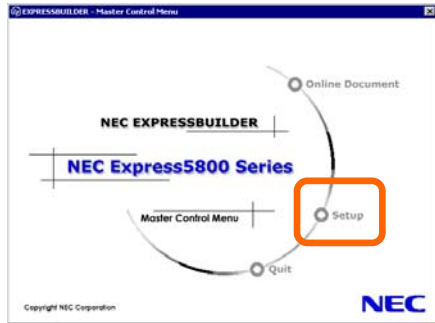

TIPS: You can also display the popup menu by right-clicking the screen shown right.

4. Click [NEC MWA Manager].
NEC MWA installer starts up. Follow the instructions to install.

Confirmation of the Kernel Version

The following explains how to check the version of the kernel which is the core of the software achieving fault tolerance. Perform this procedure when you need to check the version of the operating kernel. (e.g., when you add devices to the NEC Express5800/ft series.)

A dedicated tool for checking the version is provided. Confirm the version following the procedure below:

1. Execute the following command:

```
> uname -a
```

The version of the operating kernel is displayed.

This completes confirmation of the version.

Chapter 6

Troubleshooting

This chapter describes what to do when files needed to operate the OS are damaged and any trouble occur on the product.

System Repair

For procedure of repairing RAID when disk failures occur, refer to Chapter 4 “Linux Setup” (page 4-1).

IMPORTANT:

- If hard disks cannot be recognized, the system cannot be repaired.
 - You need to log in as a root user to make this setting.
-

If fsck was started while booting and was stopped during the process, execute fsck for each md devices.

```
>fsck -y /dev/md*
```

```
*: md number
```

Troubleshooting

This section describes what you should do when a trouble occurs in the product.

Problems with NEC EXPRESSBUILDER

When the server is not booted from the NEC EXPRESSBUILDER CD-ROM, check the following:

- Did you set the NEC EXPRESSBUILDER during POST and restart the server?
 - If you do not set the NEC EXPRESSBUILDER during POST and restart the server, an error message will appear or the OS will boot.
- Is BIOS configuration correct?
 - The boot device order may be specified with the BIOS setup utility of the server. Use the BIOS setup utility to change the boot device order to boot the system from the CD-ROM drive first.
 - <Menu to check: [Boot]>

When an error occurs while the NEC EXPRESSBUILDER is in progress, the following message appears. After this message appears, check the error and take the appropriate corrective action according to the error codes listed in the table below.

Message	Cause and Remedy
This machine is not supported.	This NEC EXPRESSBUILDER version is not designed for this server. Execute the NEC EXPRESSBUILDER on the compliant server.
NvRAM access error	An access to the nonvolatile memory (NvRAM) is not acceptable.
Hard disk access error	The hard disk is not connected or it is failed. Check whether the hard disk is correctly connected.

An error message will also be displayed when an error was detected during system diagnosis. Take a note or print the error message displayed, and contact your sales agent.

This page is intentionally left blank.

Appendix A

About Services

Information on NEC Express5800 ft series is provided the web at NEC Express5800 Web ASIA
PACIFIC

<http://www.nec.co.jp/express/>

N8800-048E/049E

NEC Express5800/320Lb/320Lb-R

User's Guide (Setup)



856-124164-901-AI

1st Edition

10-2004

856-124164-901-A