

EXPRESS5800 ST1400

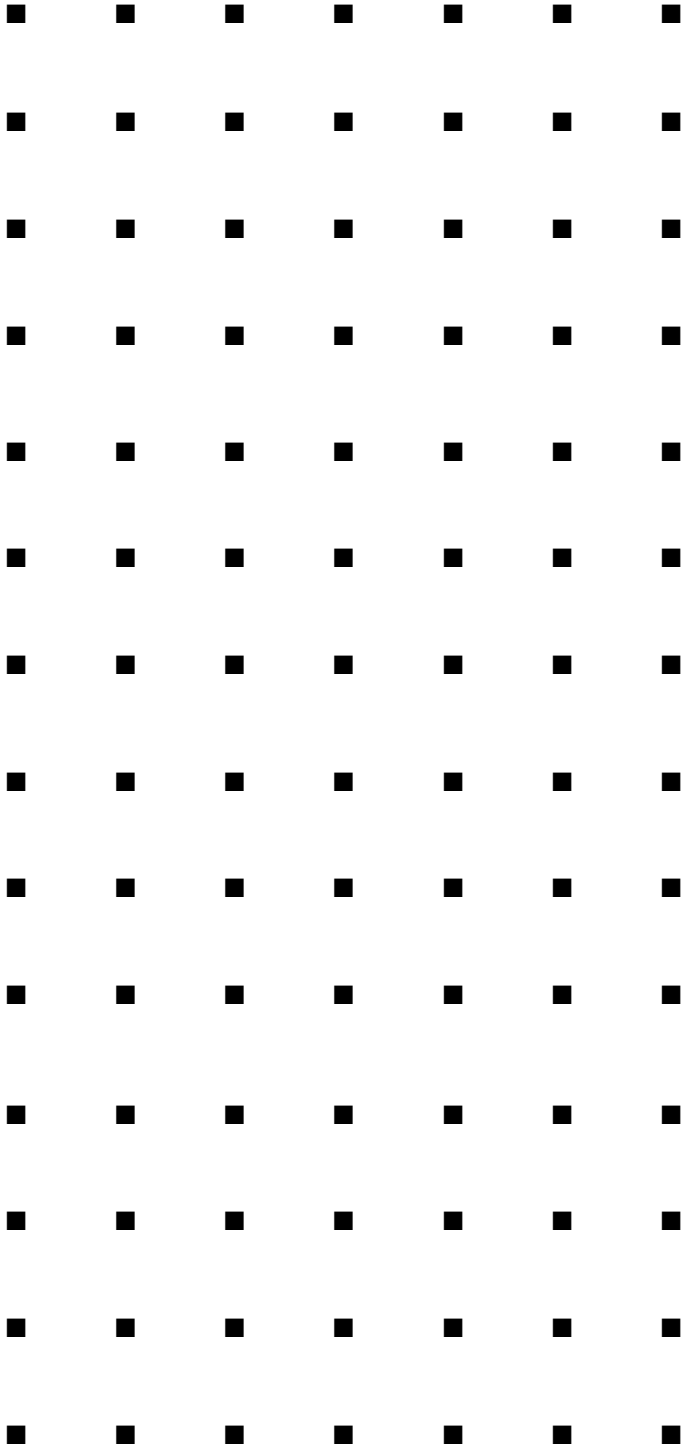

**Disk Expansion Unit
User's Guide**

EXPRESS5800 ST1400

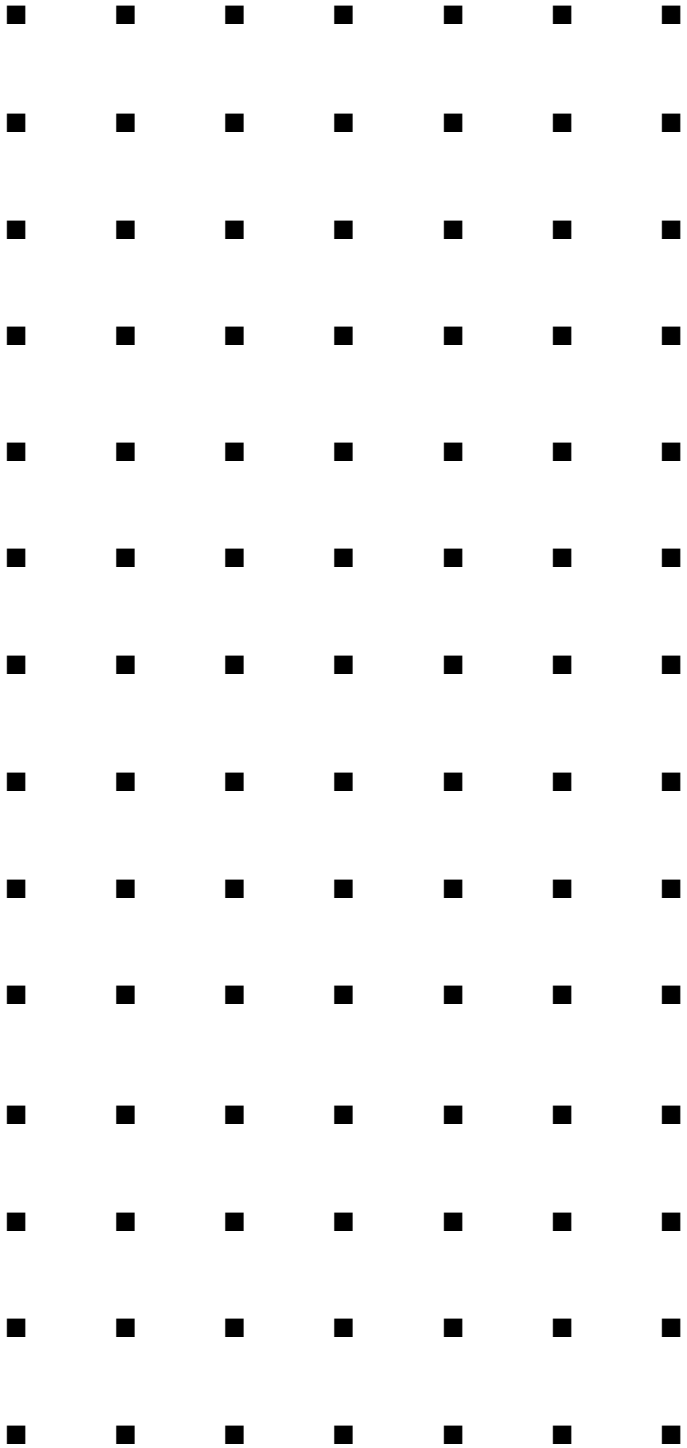

**Disk Expansion Unit
User's Guide**

Proprietary Notice and Liability Disclaimer

The information disclosed in this document, including all designs and related materials, is the valuable property of NEC Computer Systems Division (hereinafter "NEC CSD") and/or its licensors. NEC CSD and/or its licensors, as appropriate, reserve all patent, copyright and other proprietary rights to this document, including all design, manufacturing, reproduction, use, and sales rights thereto, except to the extent said rights are expressly granted to others.

The NEC CSD product(s) discussed in this document are warranted in accordance with the terms of the Warranty Statement accompanying each product. However, actual performance of each such product is dependent upon factors such as system configuration, customer data, and operator control. Since implementation by customers of each product may vary, the suitability of specific product configurations and applications must be determined by the customer and is not warranted by NEC CSD.

To allow for design and specification improvements, the information in this document is subject to change at any time, without notice. Reproduction of this document or portions thereof without prior written approval of NEC CSD is prohibited.

Trademarks

All product, brand, or trade names used in this publication are the trademarks or registered trademarks of their respective trademark owners.

PN: 456-01508-001

NEC

Copyright 1999
NEC Computer Systems Division
All Rights Reserved

Contents

Using This Guide	v
Text Conventions	vi
Related Documents	vii
Safety Notices	viii
Safety Notices for Users Outside of the U.S.A. and Canada	ix
Care and Handling	x
DEU Overview	1-1
Overview	1-2
Hot Swappable SCSI Disk Drive Bays	1-4
SAF-TE Board	1-4
DEU Controls and Indicators	1-4
Power Switch	1-5
DEU Status Indicator LEDs	1-5
Power Supply Status Indicator LEDs	1-5
Disk Drive Status Indicator LEDs	1-6
Disk Drive Status Conditions	1-6
Fibre Channel RAID Controller Switch and Indicators	1-6
I/O Panel Disk Transfer Mode LEDs	1-7
High Capacity Cooling Fans	1-7
Hot Swappable Power Supplies	1-7
I/O Panel Connectors	1-7
DEU Security	1-8
Getting Familiar with the DEU	1-9
Front View with Front Door Closed	1-9
Front View with Front Door Opened	1-10
DEU Chassis	1-13
DEU Board Features	1-15
Rear View	1-16
Status Indicator LED Descriptions	1-17
Setting Up The DEU	2-1
Overview	2-2
Selecting a Site	2-2
Unpacking the DEU	2-3
Rack-Mount Subsystem Assembly	2-4
Before You Begin	2-4
Static Precautions	2-4
Assembly	2-5
Cabling Connections	2-8
Termination	2-8
Cables	2-8
Configurations	2-8
Setting the Line Voltage	2-15
Connecting the Power Cord(s)	2-17
Power Control Mode	2-18
Powering On The DEU	2-18

Configuring Your DEU	3-1
General Information	3-2
Static Precautions	3-2
Termination Configurations	3-3
Changing the Power Control Mode.....	3-5
DEU Cabling (JBOD)	3-6
DEU Cabling (FC-AL).....	3-7
Upgrading Your DEU	4-1
Static Precautions	4-2
Preparing Your DEU for Upgrade.....	4-3
Opening the Front Door	4-3
Hard Disk Drives.....	4-4
SCSI ID Assignment	4-4
Installing or Swapping a Hard Disk Drive in a Hot-swap Bay	4-5
Installing or Swapping a Hard Disk Drive	4-6
Removing the Power Supply	4-8
Problem Solving	5-1
Introduction	5-2
Static Precautions	5-2
Initial DEU Startup	5-2
Troubleshooting Tables	5-3

Glossary

Index

Using This Guide

The ST1400 User's Guide provides a quick reference to information about your Disk Expansion Unit (DEU) system. Its goal is to familiarize you with your DEU system and the tasks necessary for setting up your system, using the system, configuring and upgrading the system. This guide assumes that the reader is already familiar with the host system and operating system environments where the DEU will be installed.

This guide contains the following information:

- Chapter 1, “DEU Overview” provides an overview of your DEU and describes its major system components. See this chapter to familiarize yourself with your DEU.
- Chapter 2, “Setting Up Your DEU” tells you how to select a site, unpack the DEU, assemble the rack-mount subsystem, get familiar with the DEU, select the line voltage, connect the power cord(s), and power on the DEU.
- Chapter 3, “Configuring Your DEU” provides instructions for making termination configuration changes to the DEU. This chapter also includes internal system cabling information.
- Chapter 4, “Upgrading Your DEU” provides you with for upgrading your DEU with additional disk drives and power supplies.
- Chapter 5, “Problem Solving” contains helpful information for solving problems that might occur with your DEU.
- “Glossary” defines the standard acronyms and technical terms associated with the DEU.

Text Conventions

This guide uses the following text conventions.

Warnings, cautions, and notes have the following meanings:

WARNING

Warnings alert you to situations that could result in serious personal injury or loss of life.

CAUTION

Cautions indicate situations that can damage the system hardware or software.

 **Note:** Notes give important information about the material being described.

- Names of keyboard keys are printed as they appear on the keyboard. For example, **Ctrl**, **Alt**, or **Enter**.
- Text or keystrokes that you enter appear as boldface type. For example, type **abc123** and press **ENTER**.
- File names are printed in uppercase letters. For example, **AUTOEXEC.BAT**.

Related Documents

In addition to this guide, the following system documentation is included with your DEU either as electronic files on EXPRESSBUILDER or as paper copy shipped with your DEU.

- ***System Release Notes***

Release Notes provide you with the latest information about your DEU. This information was not available at the time your user's guide was developed.

Safety Notices



- **Caution:** To reduce the risk of electric shock which could cause personal injury, follow all safety notices. The symbols shown are used in your documentation and on your equipment to indicate safety hazards.
- **Warning:** Lithium batteries can be dangerous. Improper handling of lithium batteries may result in an explosion. Dispose of lithium batteries as required by local ordinance or as normal waste if no local ordinance exists.
- **Warning:** The detachable power supply cords are intended to serve as the disconnect devices.
- **Warning:** This equipment has a 3-wire, grounded power cords. To prevent electrical hazards, do not remove or defeat the ground prong on the power cords. Replace a power cord if it gets damaged. Contact your dealer for an exact replacement.
- **Warning:** The DC push-button on/off switch on the front panel does not turn off the system AC power. Also, +5vdc is present on the system board whenever the AC power cords are connected between the system and an AC outlet. Before doing the procedures in this manual, make sure that your system is powered off and unplug the AC power cords from the back of the chassis. Failure to disconnect power before opening your system can result in personal injury and equipment damage.

In the U.S.A. and Canada, the power cord must be a UL-listed detachable power cord (in Canada, CSA-certified), type ST or SJT, 16 AWG, 3-conductor, provided with a molded-on NEMA type 5-15 P plug cap at one end and a molded-on cord connector body at the other end. The cord length must not exceed 9 feet (2.7 meters).

Outside the U.S.A. and Canada, the plug must be rated for 250 VAC, 10 amp minimum, and must display an international agency approval marking. The cord must be suitable for use in the end-user country. Consult your dealer or the local electrical authorities if you are unsure of the type of power cord to use in your country. The voltage change occurs via a switch in the power supply.

- **Warning:** Under no circumstances should the user attempt to disassemble the power supply. The power supply has no user-replaceable parts. Inside the power supply are hazardous voltages that can cause serious personal injury. A defective power supply must be returned to your dealer.

Safety Notices for Users Outside of the U.S.A. and Canada

- **PELV (Protected Extra-Low Voltage) Integrity:** To ensure the extra-low voltage integrity of the equipment, connect only equipment with mains-protected electrically-compatible circuits to the external ports.
- **Remote Earths:** To prevent electrical shock, connect all local (individual office) computers and computer support equipment to the same electrical circuit of the building wiring. If you are unsure, check the building wiring to avoid remote earth conditions.
- **Earth Bonding:** For safe operation, only connect the equipment to a building supply that is in accordance with current wiring regulations in your country. In the U.K., those regulations are the IEE.

Care and Handling

Use the following guidelines to properly handle and care for your system.

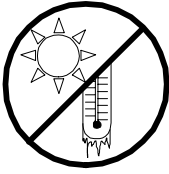

Protect the system from extremely low or high temperatures. Let the system warm (or cool) to room temperature before using it.



Keep the system away from magnetic forces.



Keep the system dry. Do not wash the system with a wet cloth or pour fluid into it.

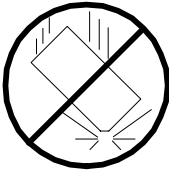

Protect the system from being bumped or dropped.



Check the system for condensation. If condensation exists, allow it to evaporate before powering on the system.



Keep the system away from dust, sand, and dirt.

1

DEU Overview

- Overview
- Hot Swappable SCSI Disk Drive Bays
- SAF-TE Board
- DEU Controls and Indicators
- I/O Panel Disk Transfer Mode LEDs
- High Capacity Cooling Fans
- Hot Swappable Power Supplies
- I/O Panel Connectors
- DEU Security
- Getting Familiar with the DEU
- DEU Chassis
- DEU Board Features
- Status Indicator LED Descriptions

Overview

The Disk Expansion Unit (DEU) provides fault-tolerant storage in a subsystem-based SAF-TE compliant RAID enclosure. See Figure 1-1.

The SAF-TE compliant interface provides a standard, non-proprietary means for the RAID subsystem to support status signals, hot swapping drives and enclosure monitoring. Combined with the RAID management software, additional levels of fault tolerance can be maintained. Additionally, DEU models that include the Fibre Channel Arbitrated Loop (FC-AL) RAID Controller support extended cabling distances and increased performance.

 **Note:** Within this manual DEU configurations that do not include the Fibre Channel RAID Controller are referred to as JBOD (Just a Bunch of Disks). Configurations that include the Fibre Channel RAID Controller are referred to as FC-AL.

The DEU includes a fourteen-drive enclosure designed to support a host system-based architecture. The architecture includes dual SCSI backplanes supporting fourteen Ultra2 SCSI (LVD) hard disk drives. Each SCSI backplane supports seven drives.

The DEU is available as a tower-based system or as a rack-mount system (fits into a standard EIA 19-inch rack assembly). See Figure 1-2.

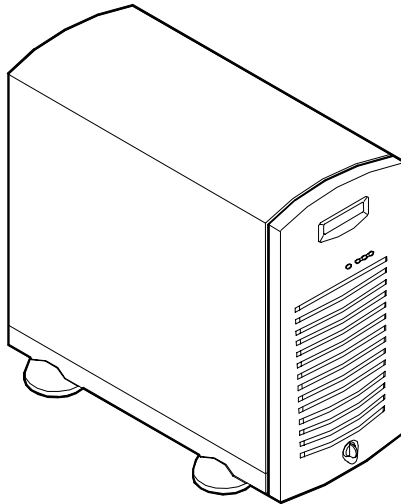

Figure 1-1. Tower-Based DEU Front View

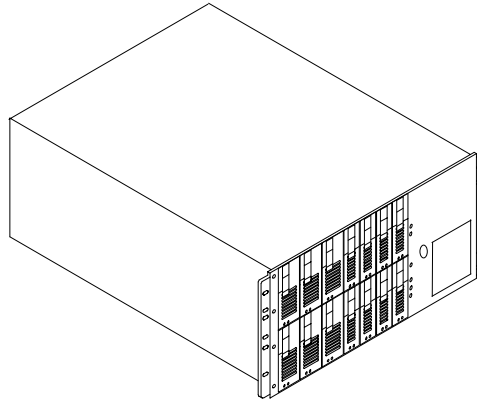

Figure 1-2. Rack-Mount DEU Front View

The DEU features the following major components:

- Easy cabling to one or more host bus adapters.
- Fourteen hot-swap SCSI hard disk drive bays accessible from the front of the chassis. The bays are secured behind a lockable front door (tower version only) where the drives can be swapped in or out of the DEU without powering it down, if a RAID controller is used. The bays support up to fourteen drives, six of which may be 1.6". Disk drives are high performance hot-swappable 7,200 and 10,000 RPM Ultra2 (LVD) SCSI hard disk drives.
- Dual SCSI backplanes both Ultra-2 (LVD) ready.
- Hardware monitors (temperature, fans, and voltage) and software monitors to indicate failures.
- Keylock at the front of the chassis (tower version only) and two metal padlocks loops (one at the back of each side panel). A key-locking front door that deters unauthorized access to the drives, controllers, and power switch; one intrusion sensor switch for the front of the chassis (tower version only) and two power-interlock switches for the left and right side panels.
- LEDs provide failure notifications.
- Remote Start control of disk drive spin up.
- Complete support of SAF-TE v1.0 standards (SCSI-Accessed Fault-Tolerant Enclosure) protocol.
- Automatic SCSI bus termination.

The DEU system is designed for minimum downtime. Thus, the DEU contains the following:

- Up to two power supplies for power system redundancy. With two power supplies, the DEU will continue to operate with a single power supply failure. The self-contained power supply units can be easily hot-swapped from the rear of the chassis.
- SCSI disk drive bays accessible from the front of the chassis.
- Dual hot-swap SCSI disk drive backplanes, each of which supports seven drives. A failed drive can be removed and a new drive installed without system power being turned off, if an optional Redundant Array of Independent Disks (RAID) controller is used.
- High degree of SCSI disk fault tolerance and advanced disk array management features through the use of RAID technology.
- Six high capacity cooling fans, plus up to two power supply cooling fans.

FC-AL DEU models that include the Fibre Channel RAID Controller include the following additional features:

- Increased data throughput to 100MB/second
- Simpler cabling interface provides freedom from SCSI cabling limitations and reliability risks
- Indirect connection to multiple hosts and networks (looping) via hubs and switches provides a new realm of storage configurations
- Up to 126 devices can exist on a fibre channel connection thereby providing increased data storage capacity.

Hot Swappable SCSI Disk Drive Bays

The DEU supports a variety of standard SCA-2 hard disk drives. The chassis includes fourteen hot-swap SCSI hard disk drive bays for mounting up to fourteen SCA-2 hard disk drives in easily removable drive carriers. Six bays can accommodate either 1.0" or 1.6" drives, while eight bays can only accommodate 1.0" drives.

 **Note:** The DEU contains a hot-swap back plane that require an 80-pin single connector attachment (SCA-2) connector on the drives that you install.

The design of the drive mounting uses a carrier rail system making it possible to "hot swap" a drive without shutting down the DEU.

 **Note:** All drives in a RAID array should be of the same capacity. If the drives are mixed, all of the drives in the array are assigned the capacity of the smallest size drive.

SAF-TE Board

The DEU has a SAF-TE (SCSI-Accessed Fault-Tolerant Enclosure) board that provides an interface to the disk subsystem that supports status signals, hot swapping drives, and enclosure monitoring.

The transport mechanism for the standardized alert detection and status reporting is the SCSI bus. Disk drives, power supplies, cooling fans, and temperature are continually monitored and the conditions then reported over the SCSI bus to the host system. When used with RAID management software the user can be alerted of impending or imminent conditions requiring attention. This allows the user to react to conditions that could normally go unnoticed until data loss.

DEU Controls and Indicators

The DEU contains a power switch and several status indicator LEDs to assist in determining the current state of the DEU subsystem. The following subsections describe power switches and status indicator LEDs.

Power Switch

The power switch is located inside the locking front door (tower version only) and controls DC power to all internal components. This positioning of the switch deters unauthorized users from powering down the DEU provided the door is locked. The switch is recessed to prevent inadvertent activation during service activity.

DEU Status Indicator LEDs

There are six status indicator LEDs to assist in determining the current state of the DEU system. The following subsections describe the LEDs. Also, see Figure 1-5 and Table 1-1.

DC Power

The Power-On LED indicates if power has been applied to the DEU. The LED illuminates steady green to signify that the DEU system has power applied.

Power Alarm

The Power Supply Status LED indicates the condition of the system power supplies. The LED will be OFF when the power supplies are functioning normally and will change to amber if one of the power supplies should fail. This condition will only be indicated if a RAID controller is present or if system management software (ESMPRO) is running on the host.

DC Power Status LEDs on the rear of the unit indicate which supply is defective.

Fan Alarm

Two Fan Status LEDs indicate the condition of the cooling fans located behind each SCSI backplane. The LED will be OFF when all of the fans are functioning normally and will change to amber if any of the fans should fail. This condition will only be indicated if a RAID controller is present or if system management software (ESMPRO) is running on the host.

Array Alarm

Two Array Alarm LEDs indicate the status of the disk array subsystems. When OFF, the LED indicates normal array activities.

When the LED changes to amber, it indicates the RAID array is in a critical state. A subsequent disk failure in this state will cause array failure. The disk drive that is causing the condition is indicated by a steady amber LED located at the disk drive. This condition will only be indicated if a RAID controller is present. Refer to Table 1-4 Disk Drive Status Conditions, for more information.

Power Supply Status Indicator LEDs

The Power Supply Status indicator LEDs for each power supply are provided on the rear of the chassis. The indicator LEDs aid in showing a specific power supply status and in identifying a failed (or problem) power supply. When illuminated steady green, the Power Supply Status LED indicates AC power is supplied to the power supply. An illuminated DC Power Status LED (amber) indicates the failed or disconnected power supply. See Table 1-2.

Disk Drive Status Indicator LEDs

Disk Drive Status indicator LEDs for each disk drive are provided inside the front door to aid in showing a specific drive's activity and in identifying the failed (or problem) disk drive. These LEDs are aligned with their respective drive/drive bay. When illuminated steady or blinking green, the Disk Drive Activity LED indicates normal drive activity. An illuminated disk drive status LED (amber) indicates the failed or problem drive. Refer to the next section for more information.

Disk Drive Status Conditions

The disk drive status indicator LEDs are active only when the DEU is connected to a host that is using a RAID controller. When illuminated amber, this indicates a failed or problem drive. The conditions that can cause this are listed below.

- Faulty or rebuild stopped (steady amber)
- Rebuild in progress (blinking amber)

Fibre Channel RAID Controller Switch and Indicators

The Fibre Channel RAID Controller, available on specific DEU models, includes a keylock power switch and several status indicator LEDs to assist in determining the current state of the controller. The following subsections describe the power switch and status indicator LEDs. Refer to Figure 1-6 and Table 1-2.

Power Switch

The power switch is located on the Fibre Channel RAID Controller front panel and controls DC power to the controller. This keylock switch deters unauthorized users from powering down the controller.

DC Power

The Power-On LED indicates if power has been applied to the Fibre Channel RAID Controller. The LED illuminates steady green to signify that the controller has power applied.

Controller Alarm

The Controller Alarm LED indicates the status of the Fibre Channel RAID Controller. When OFF, this LED indicates the controller is functioning properly.

This amber LED is on for approximately 50 seconds when power is applied to the RAID controller. During this time, the controller performs a power up self-test. After the self-test completes the controller alarm LED turns off. If this LED does not turn off, this indicates the RAID controller has failed. Refer to Table 1-2 for more information.

FC-AL A ACT Indicator

When illuminated steady or blinking green, the FC-AL A ACT LED indicates data activity within FC-AL Loop A (Channel A) of the RAID Controller.

FC-AL A Link Indicator

This green LED is lit indicating the RAID Controller FC-AL Loop A is connected to the FC-AL Hub.

FC-AL B ACT Indicator

When illuminated steady or blinking green, the FC-AL B ACT LED indicates data activity within FC-AL Loop B (Channel B) of the RAID Controller.

FC-AL B Link Indicator

This green LED is lit indicating the RAID Controller FC-AL Loop B is connected to the FC-AL Hub.

High Capacity Cooling Fans

The cooling system consists of three high-performance fans per SCSI backplane. These fans draw air across the drives and electronics of the system and exhaust out through the rear panel. Also there is one fan in each of the power supplies.

Hot Swappable Power Supplies

Up to two power supplies are incorporated as part of a fault-tolerant hot-swap design. In the event of a power supply failure, the load is transferred to the remaining power supply without interruption to normal operation.

 **Note:** The power supplies are not hot swappable unless there are two supplies installed.

The two 300 watt power supplies are switch-selectable for 115 or 230 VAC at an operating frequency of 50/60 Hz. They are designed to comply with existing emission standards and provide sufficient power for a fully loaded system configuration. The power supply voltage selection switch is factory set to 115Vac for systems used in the United States; it is set to 230Vac for systems used in Europe.

If a failure occurs, the Power Supply Status LED will illuminate amber. The PSU “DC Good” LED will not be illuminated on the failed power supply, see *Replacing a Power Supply* described later in this guide. See Table 1-3, *Power Supply Status LEDs*.

I/O Panel Connectors

The I/O Panel connects the subsystem’s bus to the External Host Bus Adapter. Each SCSI bus has two 68-pin very high density (VHD) SCSI connectors for a total of four connectors.

I/O Panel Disk Transfer Mode LEDs

Each SCSI channel connection on the I/O panel contains a cluster of four green LEDs that define the mode of data transfer between the DEU and Host. Refer to Table 1-6 for information on the data transfer modes defined by these LEDs.

DEU Security

The front panel of the tower-based DEU contains a mechanical lock to prevent access to the front of the chassis. In addition, each side cover contains a padlock loop (padlock not provided) located on the rear of the chassis to prevent removal of the side covers and access to the inside of the DEU chassis.

The DEU chassis includes an intrusion switch for the front cover and interlock switches for both the left side and the right-side covers (as viewed from the front). When any of these covers are opened, the switch transmits an alarm signal to the SAF-TE board, where server management software processes the signal. The side cover switches also operate as interlock switches controlling power shut down to the DEU for safety reasons.

Security with the rack-mount system is identical to the tower-based system stated above, except that there is no front cover or front cover intrusion switch associated with the rack-mount system.

Getting Familiar with the DEU

Before setting up the DEU, you should become familiar with its features, such as the location of the DEU's front and rear panel switches, indicators and connectors, etc. Note that this section describes the tower-based system controls (switches and indicators) and connectors, which are identical for the rack-mount system.

Front View with Front Door Closed

Figure 1-3 shows the location of the front DEU features (tower-based unit only).

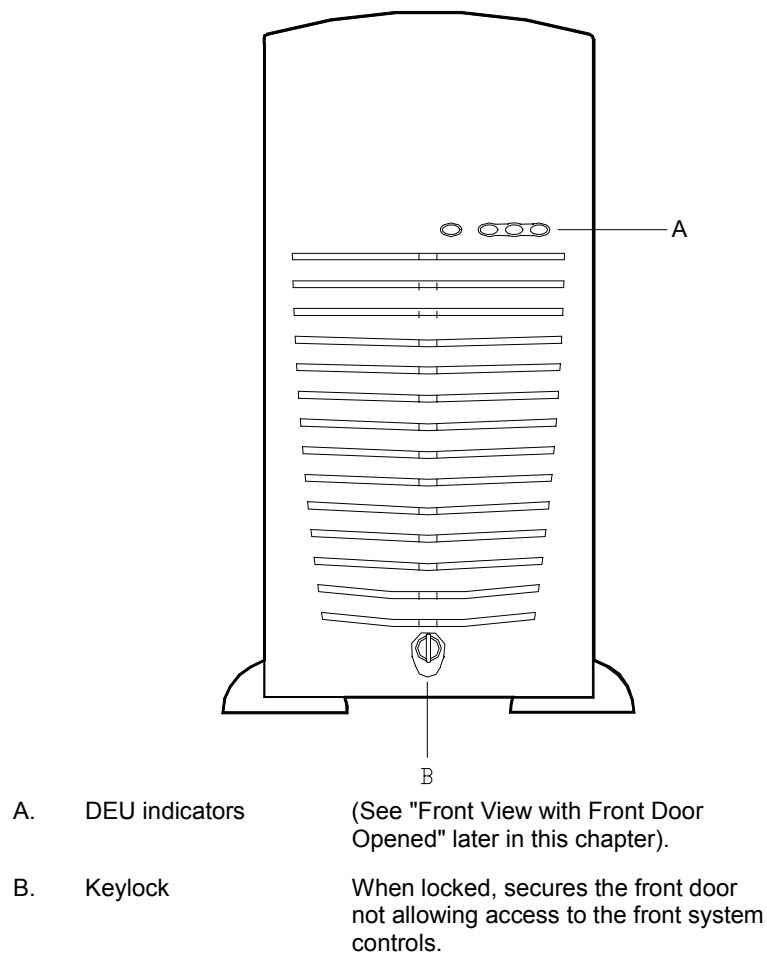

Figure 1-3. Front Features

Front View with Front Door Opened

Refer to Figure 1-4 and open the front door of the cabinet as follows (tower-based system only).

1. If door is locked, unlock the front door.
2. Pull the bottom of the front door out and tilt up until it is aligned level with the top of the cabinet, then push the door back directly over the top of the cabinet as far as it will go.

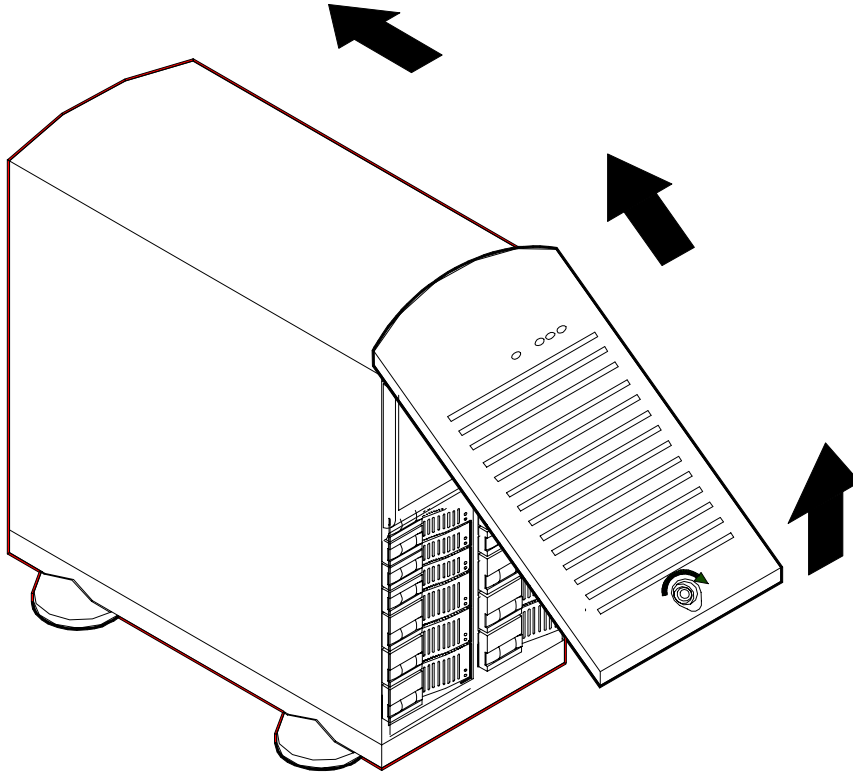
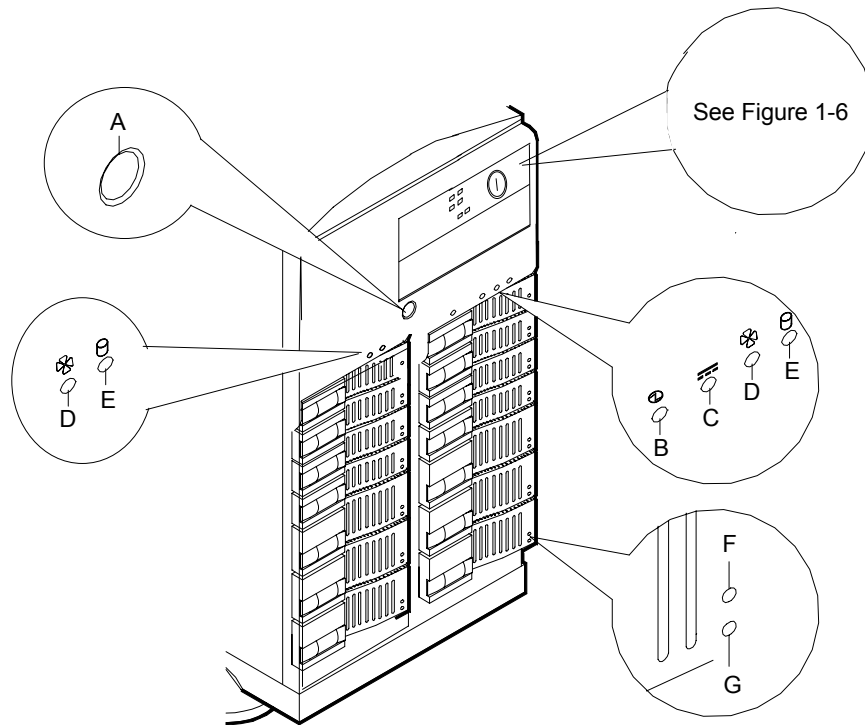

Figure 1-4. Opening the Front Door

Figure 1-5 shows the location of the front system controls and indicators.



- | | | |
|----|-------------------------|---|
| A. | DC power ON/OFF switch | *Press to turn DC power on or off. |
| B. | DC power ON/OFF LED | See Table 1-1, "System Status Indicator LEDs" that follows. |
| C. | Power alarm | See Table 1-1, "System Status Indicator LEDs" that follows. |
| D. | Fan alarm | See Table 1-1, "System Status Indicator LEDs" that follows. |
| E. | Array alarm | See Table 1-1, "System Status Indicator LEDs" that follows. |
| F. | Disk drive status LED | See Table 1-4, "Drive Status Indicator LEDs" that follows. |
| G. | Disk drive activity LED | See Table 1-4, "Disk Drive Status Indicator LEDs" that follows. |

*Functional in Local Power Control Mode Only. Refer to *Changing the Power Control Mode* found later in this chapter.

Figure 1-5. System Controls and Indicators

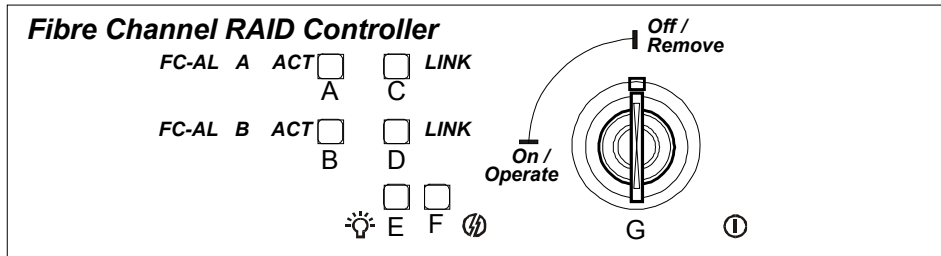

- | | | |
|----|---------------------------|---|
| A. | FC-AL A ACT LED | See Table 1-2, "Fibre Channel RAID Controller Indicator LEDs Table" that follows. |
| B. | FC-AL B ACT LED | See Table 1-2, "Fibre Channel RAID Controller Indicator LEDs Table" that follows. |
| C. | FC-AL A Link LED | See Table 1-2, "Fibre Channel RAID Controller Indicator LEDs Table" that follows. |
| D. | FC-AL B Link LED | See Table 1-2, "Fibre Channel RAID Controller Indicator LEDs Table" that follows. |
| E. | Power On LED | See Table 1-2, "Fibre Channel RAID Controller Indicator LEDs Table" that follows. |
| F. | RAID Controller Alarm LED | See Table 1-2, "Fibre Channel RAID Controller Indicator LEDs Table" that follows. |
| G. | Power Switch | Keylock switch turns RAID Controller DC power on or off. |

Figure 1-6. Fibre Channel RAID Controller Controls and Indicators

DEU Chassis

The DEU chassis is an easy-to-expand, fabricated metal structure. The major system components are shown in Figures 1-7 and 1-8.

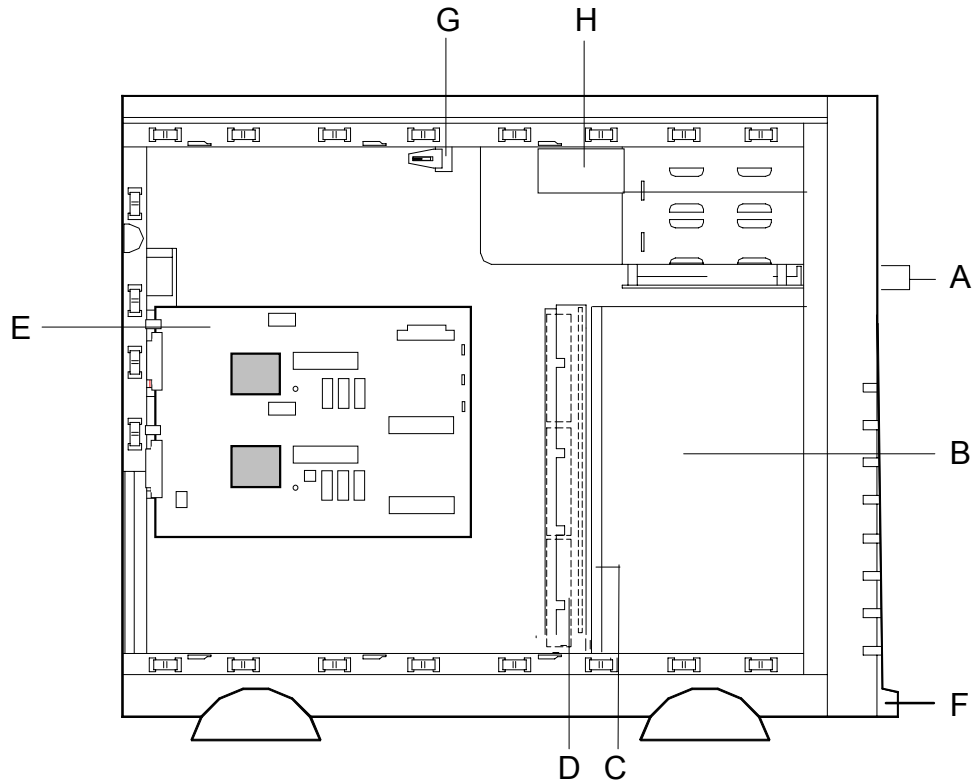

- A. SAF-TE board
- B. SCSI disk drive bays (7)
- C. SCSI backplane board – Channel 1
- D. Fans
- E. DEU board
- F. Intrusion keylock switch - Front Cover
- G. Interlock switch - Side Covers
- H. Fibre Channel RAID Controller (Available of certain models)

Figure 1-7. DEU Chassis (Left Side View)

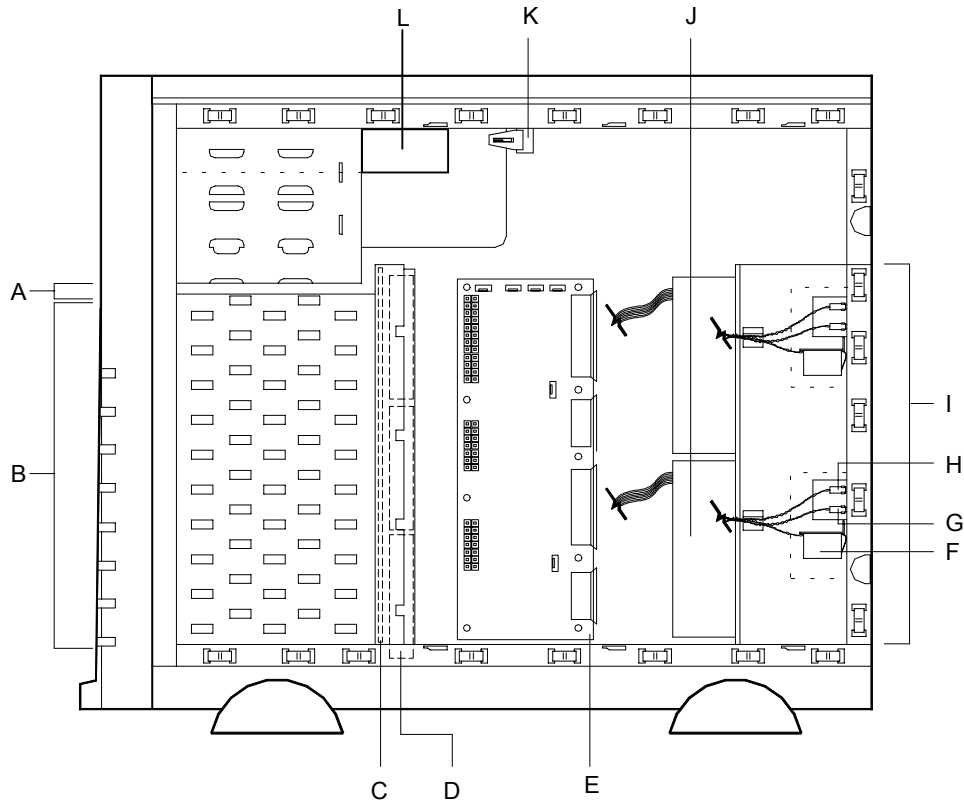

- A. SAF-TE board
- B. SCSI disk drive bays (7)
- C. SCSI backplane board – Channel 0
- D. Fans, behind SCSI disk drive bays
- E. Power supply distribution board
- F. Power available switch
- G. DC power LED
- H. Power supply status LED
- I. Power supply module slots
- J. Power supply
- K. Interlock switch
- L. Fibre Channel RAID Controller (Available of certain models)

Figure 1-8. DEU Chassis (Right Side View)

DEU Board Features

The DEU board offers a “flat” design. Figure 1-9 shows the major components on the DEU board. The following subsections describe the system board major components.

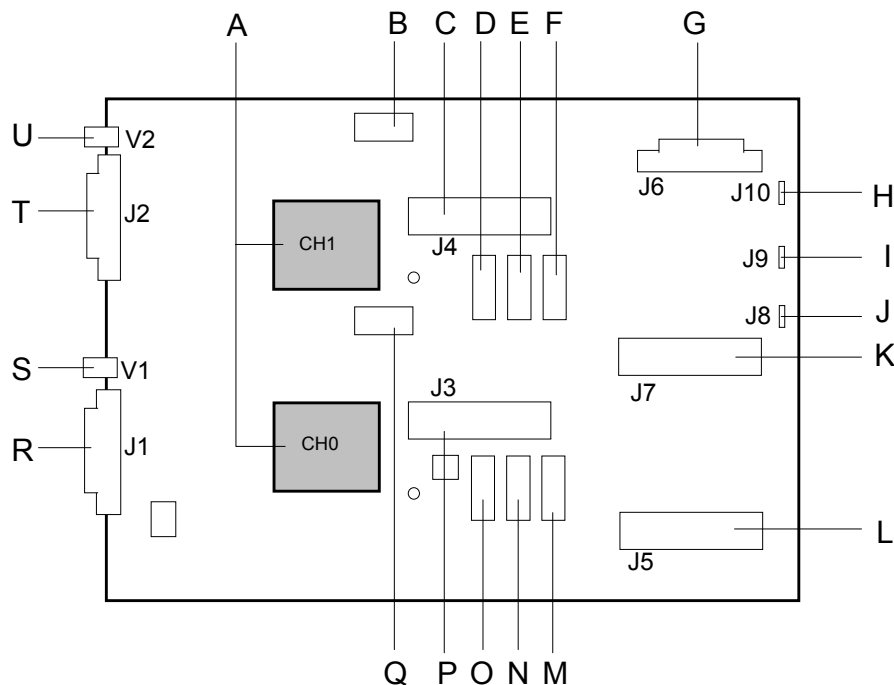

- | | | | |
|----|---|----|---|
| A. | SYM53C140 Ultra2 SCSI Bus Expander | L. | Channel 0 Wide SCSI Connector |
| B. | Channel 1 Terminator Power Switch (SW2) | M. | Channel 0 Manual Internal Terminator Switch (SW7) |
| C. | Channel 1 Wide SCSI Connector | N. | Channel 0 Manual External Termination Switch (SW5) |
| D. | Channel 1 Automatic External Termination Switch (SW4) | O. | Channel 0 Automatic External Termination Switch (SW3) |
| E. | Channel 1 Manual External Termination Switch (SW6) | P. | Channel 0 Wide SCSI Connector |
| F. | Channel 1 Manual Internal Terminator Switch (SW8) | Q. | Channel 0 Terminator Power Switch (SW1) |
| G. | Main Power Connector | R. | Channel 0 External Wide SCSI Connector |
| H. | Not Used | S. | Channel 0 DEU Status LEDs |
| I. | Power Control Mode Jumpers | T. | Channel 1 External Wide SCSI Connector |
| J. | DEU Power Switch Connector | U. | Channel 1 DEU Status LEDs |
| K. | Channel 1 External Wide SCSI Connector | | |

Figure 1-9. DEU Board Features

Rear View

Figure 1-10 shows the location of the following rear system features and controls.

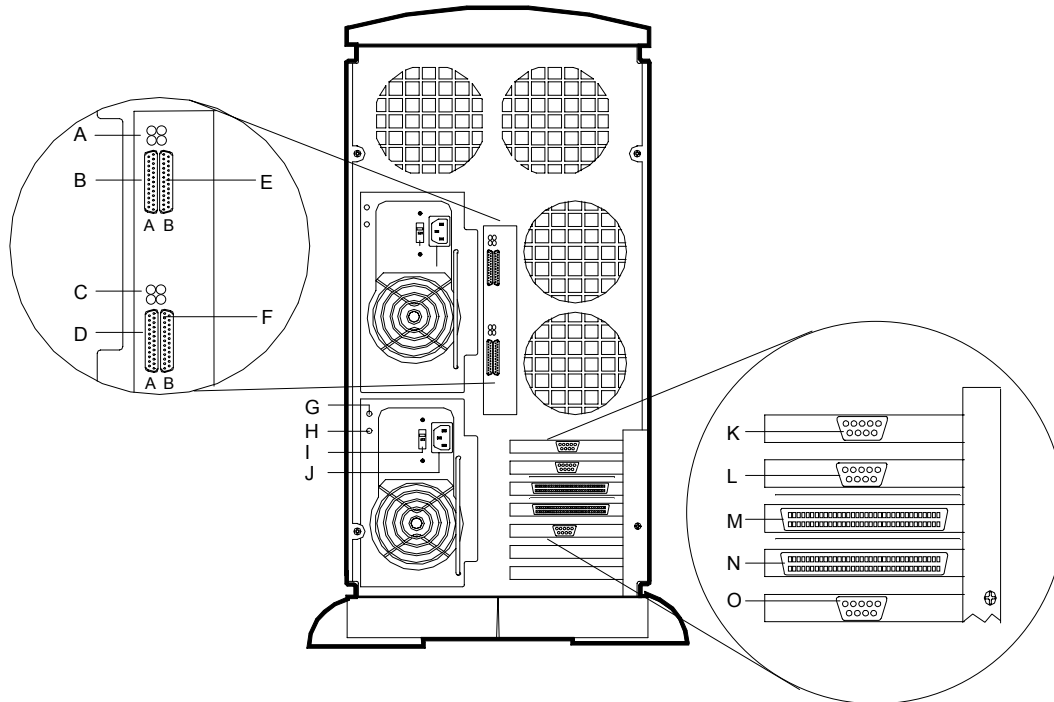

- A. Channel 1 Status LEDs
- B. Channel 1 External Wide SCSI Connector Input
- C. Channel 0 Status LEDs
- D. Channel 0 External Wide SCSI Connector Input
- E. Channel 1 External Wide SCSI Connector Output
- F. Channel 0 External Wide SCSI Connector Output
- G. Power supply status (amber light). See Table "Power Supply Status Indicator LEDs (Rear Panel)" that follows.
- H. DC power status (green light). See Table "Power Supply Status Indicator LEDs (Rear Panel)" that follows.
- I. Line voltage selector switch. Selects AC input power of 115 VAC or 230 VAC.
- J. AC input power connector. Supplies AC power to the power supply.
- K. FC-AL A External Connector to the Hub (Fibre Channel Models Only)
- L. FC-AL B External Connector to the Hub (Fibre Channel Models Only)
- M. SCSI 2 External Connector to 2nd DEU (Active-active configuration) (Fibre Channel Models Only)
- N. SCSI 3 External Connector to 2nd DEU (Active-active configuration) (Fibre Channel Models Only)
- O. Heartbeat Connector to Heartbeat Connector on 2nd DEU (Fibre Channel Models Only)

Figure 1-10. Rear Features and Controls

Status Indicator LED Descriptions

Tables 1-1 through 1-6 list the System Status Indicator LEDs, the Fibre Channel Controller Indicator LEDs, the Disk Drive Status Indicator LEDs, the Disk Drive Status Abnormal Conditions, the Power Supply Status Indicator LEDs, along with a description of each LED indicator.

Table 1-1. System Status Indicator LEDs

LED	Status	Description	Response
DC Power ON/OFF	Off	DC power OFF	None required (normal)
	ON (Green)	DC power ON	None required (normal)
Power Alarm ¹	Off	Not active	None required (normal)
	ON (Amber)	Failure has occurred in one or more power supplies (see the "Power Supply Status Indicators" table DC Power Status "Amber" that follows.)	
Fan Alarm ¹	Off	All fans operating normally	None required (normal)
	ON (Amber)	Fan failure	Replace fan in chassis or replace power supply
Array Alarm ¹	Off	Always OFF unless RAID is installed	None required (normal)
	ON (Amber)	RAID Array failure	Replace disk drive with amber light illuminated

¹Valid only when a controller is present or system management software (ESMPRO) is running on the host.

Table 1-2. Fibre Channel RAID Controller Indicator LEDs

LED	Status	Description	Response
DC Power ON/OFF	Off	RAID Controller DC power OFF	None required (normal)
	ON (Green)	RAID Controller DC power ON	None required (normal)
RAID Controller Alarm	Off	RAID Controller operating Normally	None required (normal)
	ON (Amber)	Initial power up of the RAID Controller, the controller is performing a Self-test.	None required (normal)
		Failure has occurred in the RAID Controller.	Replace the Fibre Channel RAID Controller
FC-AL A Activity Indicator LED	Off	No data activity	None required (normal)
	ON (Green)	Data activity within the controller	None required (normal)
FC-AL B Activity Indicator LED	Off	No data activity	None required (normal)
	ON (Green)	Data activity within the controller	None required (normal)
FC-AL A Link Indicator LED	Off	Controller FC-AL Loop A is disconnected from the Hub	Troubleshoot disconnected cable.
	ON (Green)	FC-AL Loop A is connected to the Hub	None required (normal)

Table 1-2. Fibre Channel RAID Controller Indicator LEDs (Continued)

LED	Status	Description	Response
FC-AL B Link Indicator LED	Off	Controller FC-AL Loop B is disconnected from the Hub	Troubleshoot disconnected cable.
	ON (Green)	FC-AL Loop B is connected to the Hub	None required (normal)

Table 1-3. Power Supply Status Indicator LEDs (Rear Panel)

LED	Status	Description	Response
Power Supply Status	Off	AC Power not available	None required (normal)
	ON (Green)	AC Power supplied to power supply	None required (normal)
DC Power Status	Off	No alarms	None required (normal)
	ON (Amber)	AC Power disconnected or power supply failed	Verify AC power is ON, reconnect AC power, or replace power supply,

 **Note:** The Disk Drive Status Indicator LEDs are active only when a RAID board is connected to the channel.

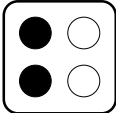
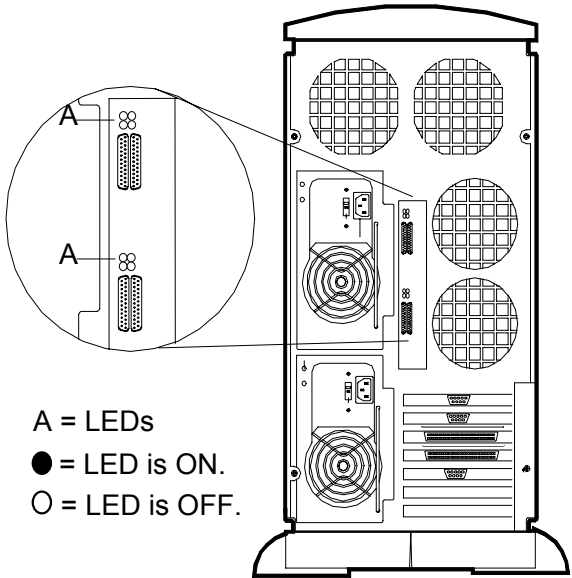

Table 1-4. Disk Drive Status Indicator LEDs

LED	Status	Description	Response
Disk Drive Activity	Off	Not accessing disk drive	None required (normal)
	ON (Green)	Accessing disk drive	None required (normal)
Disk Drive Status	Off	No alarms	None required (normal)
	ON (Amber)	(See the "Disk Drive Status Conditions" table that follows.)	

Table 1-5. Disk Drive Status Conditions (Amber Status LED)

Condition	LED
No Error	Off
Faulty or Rebuild Stopped	Steady ON
Rebuild	Slow Blink (less than one blink per second)
Identify	Fast Blink (more than three blinks per second)
Predicted Fault	Four Fast Blinks (repeat)

Table 1-6. I/O Panel Data Transfer Mode Indicator LEDs

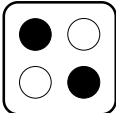
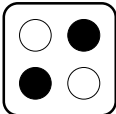
LED Configuration	Data Transfer Mode		
	Host Bus ³	DEU Bus	LED Locations
SE LVD 	Single-Ended	Single-Ended	 <p>A = LEDs ● = LED is ON. ○ = LED is OFF.</p>
	LVD	LVD	
1 	LVD	Single-Ended	
2 	Single-Ended	LVD	

1. This combination occurs if a disk on the DEU backplane is single-ended. All disks operate at ultra-wide transfer rates.
2. This combination occurs if the host adapter is single-ended. LVD-capable disks operate at ultra-wide transfer rates.
3. When used with FC-AL configurations, the Host Bus becomes the second DEU and the single-ended interface does not exist.

2

Setting Up The DEU

- Overview
- Selecting a Site
- Unpacking the DEU
- Rack-Mount Subsystem Assembly
- Cabling Connections
- Setting the Line Voltage
- Connecting the Power Cord(s)
- Power Control Mode
- Powering On The DEU

Overview

This chapter describes how to select a site, unpack the DEU, make cable connections, and power on the tower-based or rack-mount DEU units. Also, provided are the instructions for assembling the rack-mount DEU unit.

Selecting a Site

The DEU operates reliably in a typical office environment. Choose a site that is:

- Near grounded, three-pronged power outlets.

 **Note:** For the United States and Canada, this means a NEMA 5-15R outlets for 100-120 VAC or NEMA 6-15R outlets for 200-240 VAC. For other international sites, this means three-pronged power outlets applicable for the electrical code of the region.

WARNING

Be sure the power service connection is through a properly grounded outlet.

CAUTION

Be sure that the power plug from each of the power supplies is plugged into the same common ground power outlets.

- Clean, dust-free, and well ventilated. Front and rear ventilating openings kept free of obstructions. Away from sources of heat, vibration or physical shock.
- Isolated from strong electromagnetic fields and electrical noise produced by electrical devices (such as air conditioners, large fans, large electric motors, radio and TV transmitters, and high-frequency security devices)
- Spacious enough to provide at least five inches (13 centimeters) behind the DEU and three inches (eight centimeters) on each side of the DEU for proper cooling, airflow, and cable clearance.

 **Note:** Provide an additional five inches (13 centimeters) behind the DEU to facilitate changing the self-contained hot-swap power supply unit.

- Easily accessible for DEU maintenance and installation of DEU upgrades.

Unpacking the DEU

WARNING

The DEU weighs approximately 110 pounds (49.9 kg). If the DEU contains numerous optional devices, it will weigh more. To avoid personal injury, make sure you have someone help you lift or move the DEU.

When you receive the DEU, inspect the shipping containers prior to unpacking. If the shipping boxes are damaged, note the damage, and if possible, photograph it for reference. After removing the contents of the containers, keep the cartons and the packing materials. If the contents appear damaged when you unpack the boxes, file a damage claim with the carrier immediately.

Rack-Mount Subsystem Assembly

Before You Begin

Before you begin, please review the following cautions, warnings, and general guidelines.

WARNING

Be sure that power to the DEU is turned off and unplugged. All voltage is removed only when the power cords are unplugged.

- Avoid excessive vibration and shock. Dropping an electronic component can cause serious damage.
- Do not disconnect or remove parts other than those specified in the procedure.
- Do not touch I/O connector pins.
- All screws are Phillips-head, unless otherwise specified.
- On completion of any assembly or reassembly, perform a power-on test. If a fault occurs, verify that the assembly or reassembly was performed correctly. If the problem persists, see "Problem Solving" in Chapter 5.

Static Precautions

An electrostatic discharge (ESD) can damage disk drives, option boards, and other components. You can provide some ESD protection by wearing an antistatic wrist strap attached to chassis ground when handling DEU components.

Electronic devices can be easily damaged by static electricity. To prevent damage, keep them in their protective packaging when they are not installed in the DEU.

Assembly

This section describes how to assemble the rack-mount DEU into a standard EIA 19-inch rack cabinet.

 **CAUTION**

Ensure that the location of the rack-mount unit does not create an unstable condition when installed in the rack cabinet.

1. Select an appropriate location in the rack cabinet for the rack-mount unit. To improve rack stability, mount heavier items towards the bottom of the rack cabinet.

 **Note:** When planning the DEU configuration for the rack cabinet you should consider the length of the cables that interconnect DEU components.

2. Locate the two support brackets (D). Using four self tapping screws (E) supplied with the rack cabinet for each support bracket, attach the two support brackets to the vertical mounting rails (A and B) of the rack cabinet.
3. Install the four-caged nuts (C) that secure the front of the rack-mount unit to the rack cabinet. Position the caged nuts to align with the screw holes in the front bezel of the rack-mount unit.

 **Note:** The caged nuts are secured into the vertical mounting rails of the rack cabinet by inserting one side of the nut into the slot and squeeze while pressing the opposite side until it snaps into place.

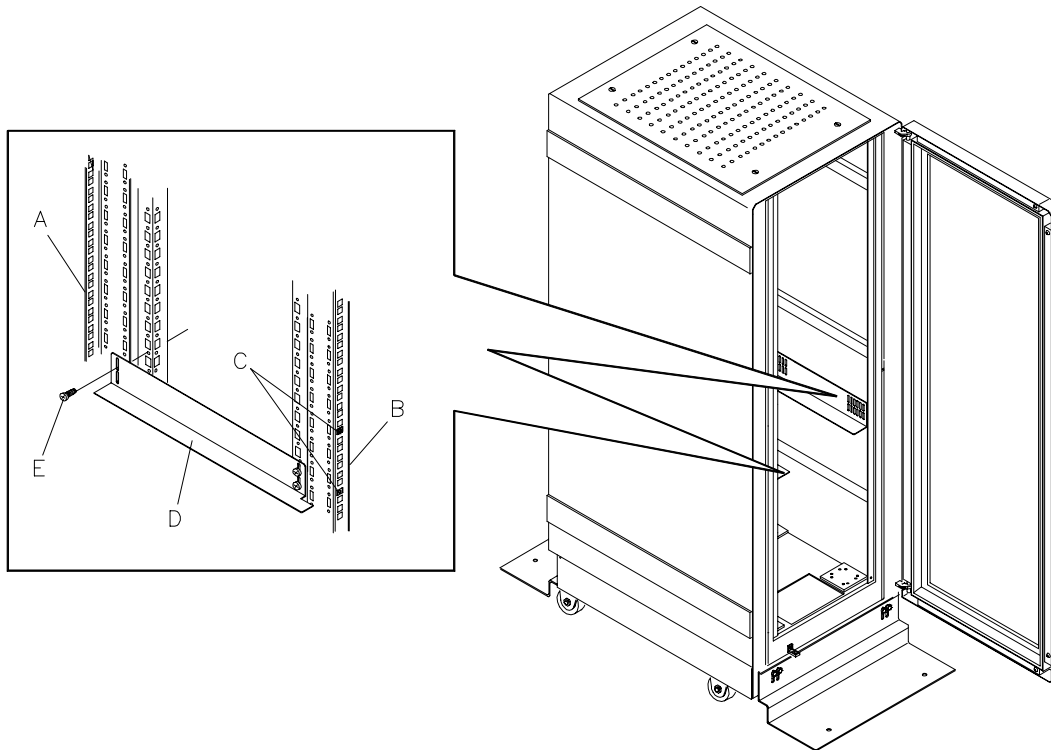

- A. Rear vertical mounting rail
- B. Front vertical mounting rail
- C. Four caged nuts
- D. Two support brackets
- E. Eight self-tapping screws

Figure 2-1. Assembling the Support Brackets in the Rack Cabinet

4. Lift the rack-mount unit (C) onto the two support brackets and slide it toward the rear of the rack cabinet.

! WARNING

It is strongly recommended that two people are present when lifting and assembling the rack-mount unit into a rack cabinet.

5. Secure the front bezel to the rack cabinet's front vertical mounting rails (B) using the four screws (E) and plastic washers (D) provided.

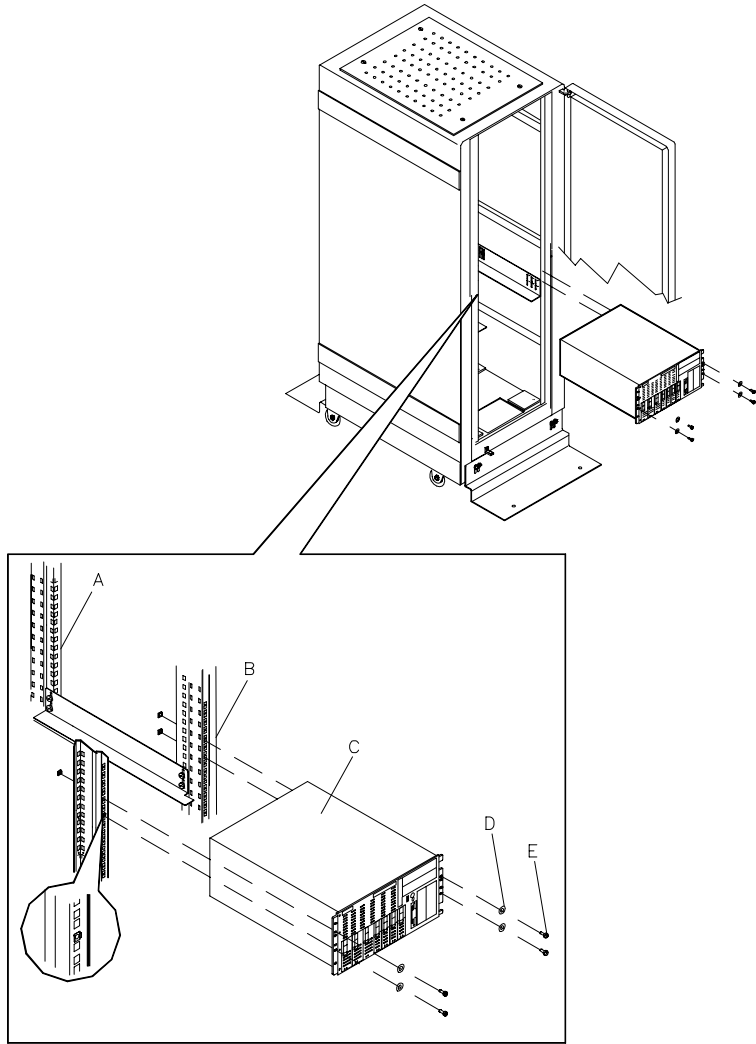

- A. Rear vertical mounting rail
- B. Front vertical mounting rail
- C. Rack-mount unit
- D. Four plastic washers
- E. Four screws

Figure 2-2. Installing the Rack-Mount Unit into the Rack Cabinet

Cabling Connections

The DEU supports the American National Standard I Ultra-2 SCSI parallel interface standards, referred to as Wide Ultra-2. This standard is backward compatible with Fast SCSI (SCSI-2 with the Wide option), also referred to as Fast Wide SCSI. Also, FC-AL models support the Fibre Channel Arbitrated Loop, ANSI/NCITS X3.272-1996 Specification.

These standards define the mechanical, electrical, and timing requirements. In compliance with these interface standards, certain limitations apply when considering the configuration, lengths of cabling, and termination.

This chapter includes both JBOD cabling configurations and FC-AL cabling configurations. FC-AL cabling connections are often referred to as “loop” connections rather than “bus” connections, which is the way SCSI devices are usually connected in JBOD cabling configurations.

FC-AL communication between hosts and devices is not necessarily accomplished by direct cable connection. Instead hubs and switches are used to create Fibre Channel storage networks. These networks connect multiple hosts and storage devices. SCSI JBOD cabling does not support such configurations.

Termination

JBOD SCSI cabling configurations require termination at both ends of the SCSI bus. If you are using a controller that provides Term Power, no change is required and SCSI bus termination will occur automatically.

The Host Controller card provides termination for one end of the SCSI bus, while the DEU board provides final termination at the other end of the bus.

See *Termination Configurations* in Chapter 3 for more information on SCSI bus termination.

FC-AL cabling configurations do not require termination.

Cabling Configurations

Figures 2-3 through 2-5 illustrate JBOD SCSI cabling configurations: single host basic configuration, dual host basic configuration and dual host cluster configuration. In the basic configuration (single host) shown in Figure 2-3, each channel of the host controller connects to a bank of up to seven disk hard disk drives in the DEU. In the basic configuration (dual host) shown in Figure 2-4, one channel of each host controller connects to a bank of up to seven disk hard disk drives in the DEU. In the dual host cluster configuration shown in Figure 2-5, each host shares control of the two banks of disk drives in the DEU.

Figures 2-6, 2-7, and 2-8 illustrate FC-AL Fibre Channel RAID Cluster Configurations.

Refer to the host controller and operating system software documentation for additional configuration information.

Contact the local sales representative for information on cables used in the following configurations.

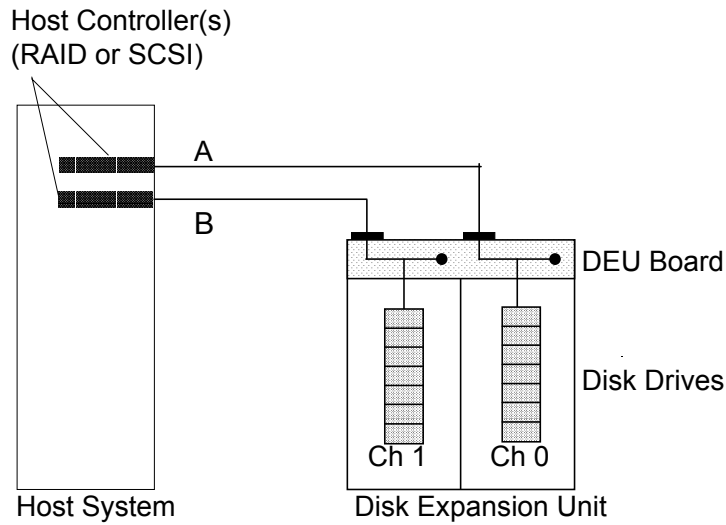

Cabling Connections			
Item	Host	DEU Connector	Description
A	Host SCSI Controller A	CHNL 0 A	External LVD SCSI Cable (Use with Host SCSI Controller) (HD68M-to-VHDCI)*
	Host RAID Controller A	CHNL 0 A	External LVD SCSI Cable (Use with Host RAID Controller) (VHDCI-to-VHDCI)*
B	Host SCSI Controller B	CHNL 1 A	External LVD SCSI Cable (Use with Host SCSI Controller) (HD68M-to-VHDCI)*
	Host RAID Controller B	CHNL 1 A	External LVD SCSI Cable (Use with Host RAID Controller) (VHDCI-to-VHDCI)*

*HD68M = High Density, 68-pin, male; VHDCI = Very High Density Connector Interface

Figure 2-3. JBOD Basic Configuration (Single Host)

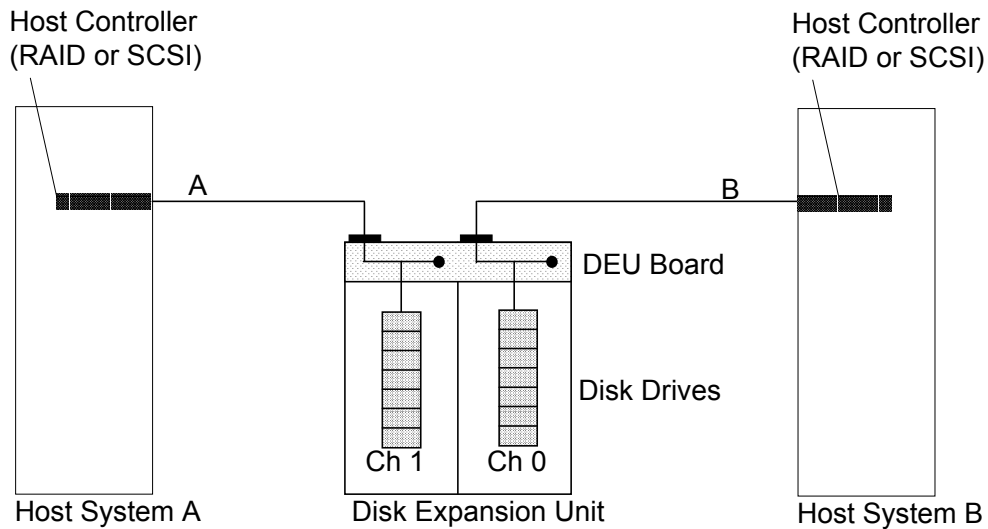

Item	Cabling Connections		Description
	Host	DEU Connector	
A	Host A SCSI Controller	CHNL 1 A	External LVD SCSI Cable (Use with Host SCSI Controller) (HD68M-to-VHDCI)*
	Host A RAID Controller	CHNL 1 A	External LVD SCSI Cable (Use with Host RAID Controller) (VHDCI-to-VHDCI)*
B	Host B SCSI Controller	CHNL 0 A	External LVD SCSI Cable (Use with Host SCSI Controller) (HD68M-to-VHDCI)*
	Host B RAID Controller	CHNL 0 A	External LVD SCSI Cable (Use with Host RAID Controller) (VHDCI-to-VHDCI)*

*HD68M = High Density, 68-pin, male; VHDCI = Very High Density Connector Interface

Figure 2-4. JBOD Basic Configuration (Dual Host)

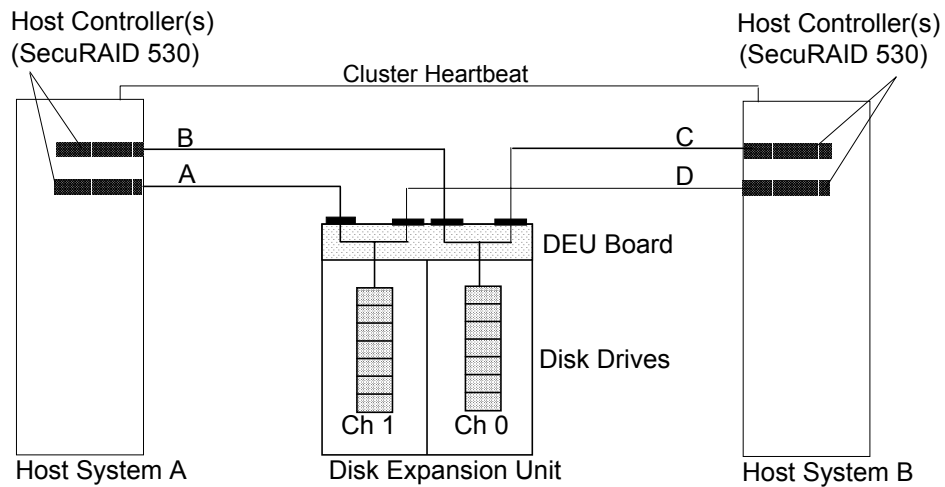

Cabling Connections			
Item	Host	DEU Connector	Description
A	Host A SecuRAID 530 Controller	CHNL 1 A	External LVD SCSI Cable (VHDCI-to-VHDCI)*
B	Host A SecuRAID 530 Controller	CHNL 0 A	External LVD SCSI Cable (VHDCI-to-VHDCI)*
C	Host B SecuRAID 530 Controller	CHNL 0 B	External LVD SCSI Cable (VHDCI-to-VHDCI)*
D	Host B SecuRAID 530 Controller	CHNL 1 B	External LVD SCSI Cable (VHDCI-to-VHDCI)*

*HD68M = High Density, 68-pin, male; VHDCI = Very High Density Connector Interface

Figure 2-5. JBOD Dual Host Cluster Configuration

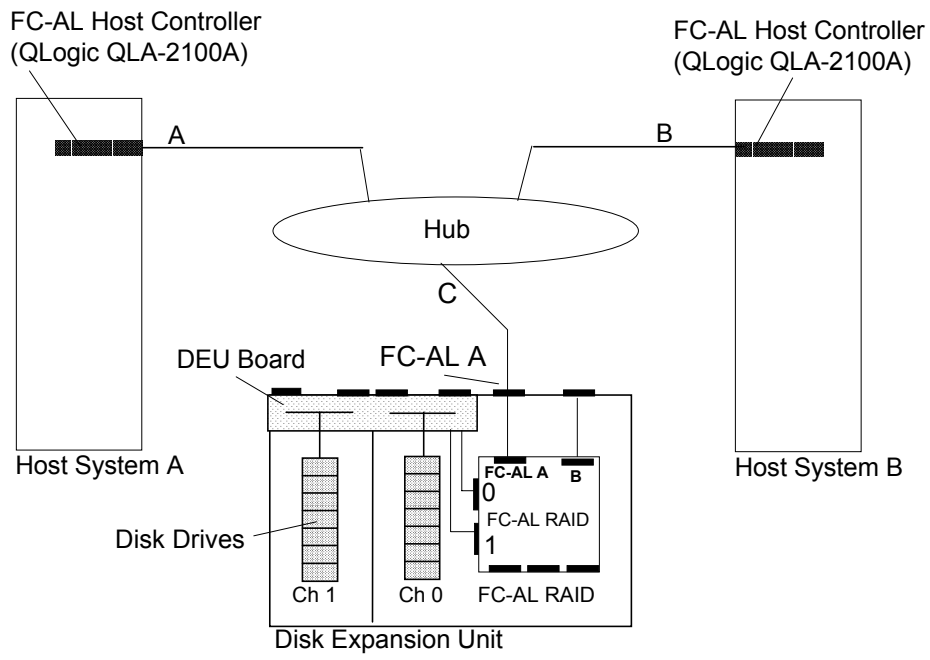

Item	Description	Cabling	
A	External HSSDC-to-DB9 Cable	HUB	Host A FC-AL Controller
B	External HSSDC-to-DB9 Cable	HUB	Host B FC-AL Controller
C	External FC-AL DB9-to-DB9 Cable	DEU FC-AL A	HUB

Figure 2-6 Single Embedded RAID Cluster Configuration (Dual Host)

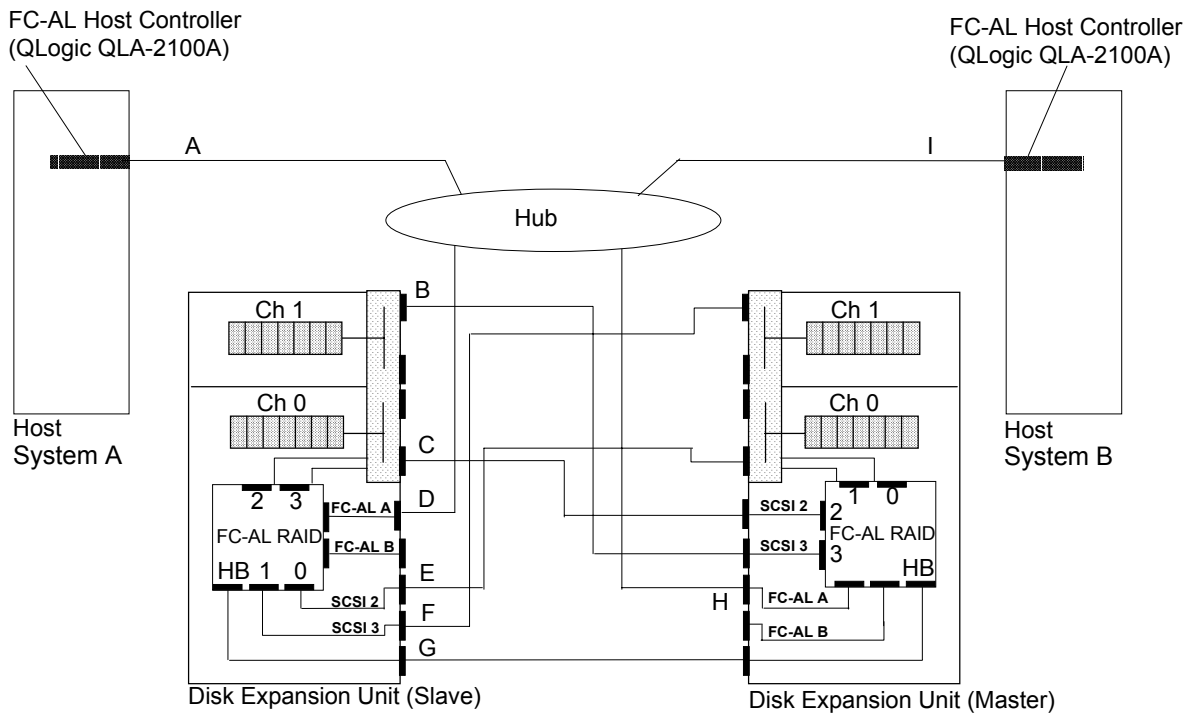

Item	Description	Cabling	
A	External HSSDC-to-DB9 Cable	Host A FC-AL Controller	HUB
B	External LVD SCSI Cable (HD68M-to-VHDCI)	DEU Slave CHNL 1 A	DEU Master SCSI 3
C	External LVD SCSI Cable (HD68M-to-VHDCI)	DEU Slave CHNL 0 A	DEU Master SCSI 2
D	External FC-AL DB9-to-DB9 Cable	DEU Slave FC-AL A	HUB
E	External LVD SCSI Cable (HD68M-to-VHDCI)	DEU Slave SCSI 2	DEU Master CHNL 0 A
F	External LVD SCSI Cable (HD68M-to-VHDCI)	DEU Slave SCSI 3	DEU Master CHNL 1 A
G	External Heartbeat Cable	DEU Slave HB	DEU Master HB
H	External FC-AL DB9-to-DB9 Cable	HUB	DEU Master FC-AL A
I	External HSSDC-to-DB9 Cable	HUB	Host B FC-AL Controller

Figure 2-7 Dual Embedded RAID Cluster Configuration (Dual Host, Single HUB)

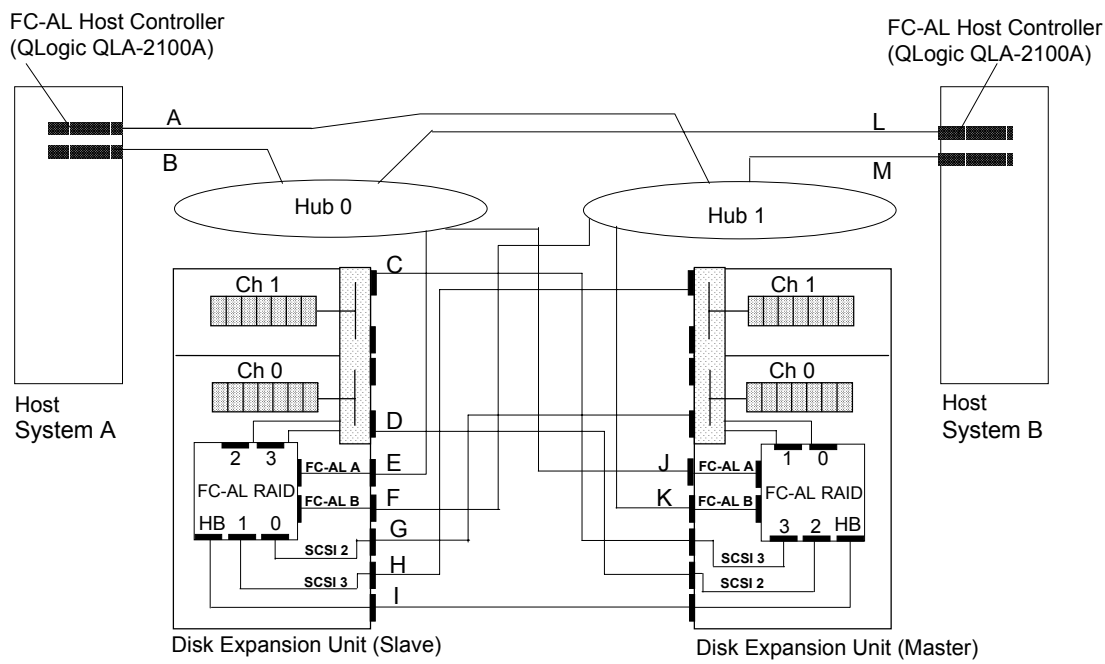

Item	Description	Cabling	
A	External HSSDC-to-DB9 Cable	Host A FC-AL Controller	HUB 1
B	External HSSDC-to-DB9 Cable	Host A FC-AL Controller	HUB 0
C	External LVD SCSI Cable (HD68M-to-VHDCI)	DEU Slave CHNL 1 A	DEU Master SCSI 3
D	External LVD SCSI Cable (HD68M-to-VHDCI)	DEU Slave CHNL 0 A	DEU Master SCSI 2
E	External FC-AL DB9-to-DB9 Cable	DEU Slave FC-AL A	HUB 0
F	External FC-AL DB9-to-DB9 Cable	DEU Slave FC-AL B	HUB 1
G	External LVD SCSI Cable (HD68M-to-VHDCI)	DEU Slave SCSI 2	DEU Master CHNL 0 A
H	External LVD SCSI Cable (HD68M-to-VHDCI)	DEU Slave SCSI 3	DEU Master CHNL 1 A
I	External Heartbeat Cable	DEU Slave HB	DEU Master HB
J	External FC-AL DB9-to-DB9 Cable	DEU Master FC-AL A	HUB 0
K	External FC-AL DB9-to-DB9 Cable	DEU Master FC-AL B	HUB 1
L	External HSSDC-to-DB9 Cable	HUB 0	Host B FC-AL Controller
M	External HSSDC-to-DB9 Cable	HUB 1	Host B FC-AL Controller

Figure 2-8 Dual Embedded RAID Cluster Configuration (Dual Host, Dual HUB)

Setting the Line Voltage

The DEU contains up to two ATX300 watt power supplies that are switch-selectable for 115 or 230 VAC at an operating frequency of 50/60Hz. The power supply voltage selection switch is factory set to 115Vac for DEUs shipped to North America; it is set to 230Vac for DEUs shipped in Europe. Line source voltages between 200 and 240 VAC are acceptable when the power supply input voltage is set to 230 VAC.



CAUTION

Before you plug the DEU power cord into an AC outlet, ensure the input line voltage setting for the power supply is correct.

To use the with line source voltages between 200 and 240 VAC, the line voltage selector switch on the power supply must be set to 230. If you set the switch to the 115 VAC position, the power supply will be damaged when you plug in the DEU.

The two power supplies installed in the DEU must have their line voltage selector switch set to the same voltage.

If you need to change the line voltage setting, perform the following steps.

 **Note:** If you are setting up the DEU for the first time, the power cord will not be connected to the rear panel of the DEU.

1. Unplug the AC power cord from the back of the chassis.
2. Insert the tip of a small screwdriver or ballpoint pen into the depression on the line voltage selector. See Figure 2-9.
3. Slide the selector switch to the left for 115 VAC or to the right for 230 VAC (line source voltage range: 220 to 240 VAC).

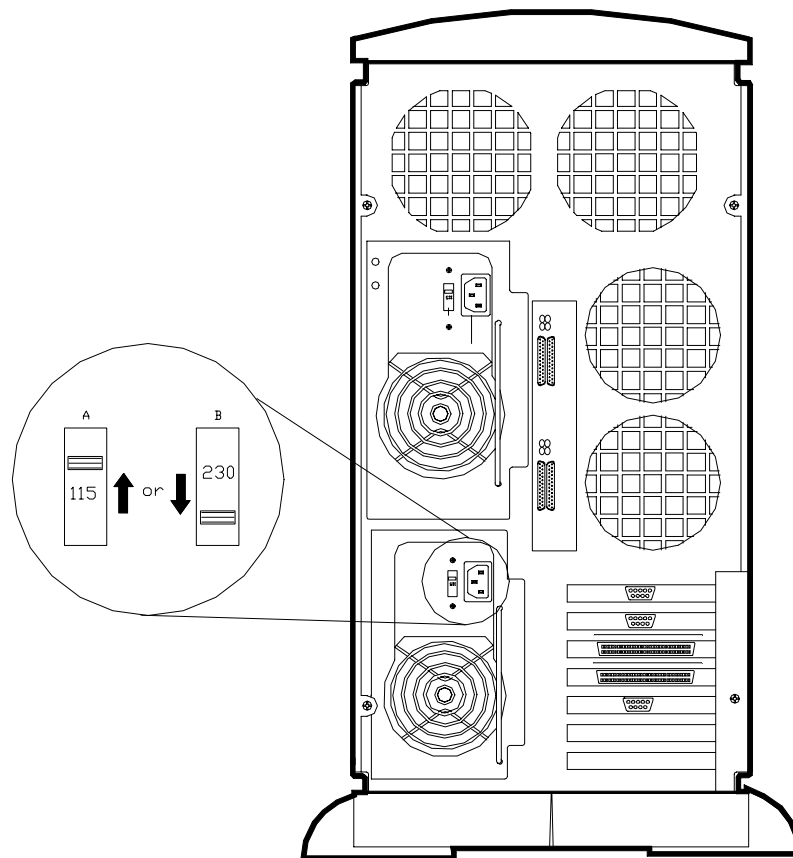

- A. Voltage selector switch set to 115 VAC
- B. Voltage selector switch set to 230 VAC

Figure 2-9. Setting the Line Voltage

Connecting the Power Cord(s)

Plug the female end of the AC power cord into the input receptacle on the rear of the power supply cage. Plug the male end of the power cord into NEMA 5-15R outlet for 100-120 VAC or NEMA 6-15R outlet for 200-240 VAC.

If the power cord(s) supplied with the DEU are not compatible with the AC wall outlet in the region, obtain a suitable power cord that meets the following criteria.

- The power cord must be rated for the available AC voltage and have a current rating that is at least 125% of the current rating of the DEU.
- The power cord connector that plugs into the wall outlet must be terminated in a grounding-type male plug designed for use in the region. It must have certification marks showing certification by an agency acceptable in the region.
- The power cord connector that plugs into the DEU must be an IEC- type CEE-22 female connector.
- The power cord must be less than 1.8 meters (6.0 feet) long.

WARNING

The DEU shipped with a power cord for each power supply. Do not attempt to modify or use the supplied AC power cord if it is not the exact type required.

CAUTION

The power plug from each of the two power supplies must be plugged into the same common ground power outlets.

Power Control Mode

The JBOD DEU models have two power control modes: Termination Power Detect and Local Power Control.

In the termination power detect mode, power to the DEU is controlled by an external termination power signal from the host. Upon detection of termination power signal, power is automatically switched on to the DEU. The front panel ON/OFF switch is not used. The DEU will power up automatically when the host system is powered up. However, a 5V standby voltage is present in the DEU as soon as the AC power cord is connected to the DEU. JBOD DEU models are factory set to operate in the termination power detect mode.

In the local mode, the front panel ON/OFF switch controls power to the DEU. DEUs that include the Fibre Channel RAID Controller (FC-AL configurations) are always configured in the Local Power Control Mode.

To change the DEU to local power control mode, perform the "*Changing the Power Control Mode*" procedure in Chapter 3. Return to Chapter 2 to complete the DEU setup.

Powering On The DEU (Local Power Control Mode)

 **Note:** The DEU offers two power control modes: SCSI bus termination power detect* and local power control**. Perform this procedure if the DEU is configured for local power control.

- * Factory Default (JBOD models).
 - ** Factory Default (FC-AL models)
-

1. Make sure the power cords are attached.
2. Press the push-button power on/off switch on the front panel of the host. Verify that the DEU power-on LED of the DEU is lit. If it is not lit, ensure the ac power cords are connected to a functional ac power source.

After a few seconds the DEU begins the internal Power-On Self Tests (POST). The Host controller automatically checks the DEU board, SAF-TE board, and all hard disk drives.

If you have problems powering on the DEU, refer to *Problem Solving* in Chapter 5 of this User's Guide.

3

Configuring Your DEU

- General Information
- Static Precautions
- Termination Configurations
- Changing the Power Control Mode
- DEU Cabling (JBOD)
- DEU Cabling (FC-AL)

General Information

WARNING

Before doing the procedures in this manual, make sure that your DEU is powered off and unplug the AC power cords from the back of the chassis. Failure to disconnect power before opening your DEU can result in personal injury and equipment damage.

CAUTION

Operating your DEU with the side panels removed can damage your DEU components. For proper cooling and airflow, always replace the side panels before powering on your DEU.

Static Precautions

An electrostatic discharge (ESD) can damage disk drives, the DEU board, and other components. You can provide ESD protection by wearing an antistatic wrist strap attached to chassis ground when handling DEU components.

Electronic devices can be easily damaged by static electricity. To prevent damage, keep them in their protective packaging when they are not installed in your DEU.

Termination Configurations

The DEU board is a two-channel SCSI repeater and includes power control circuitry. See Figure 3-1. The internal wide SCSI connector J5 connects to J16 of the channel 0 SCSI backplane (right-side backplane). DEU connector J7 connects to J16 of the channel 1 SCSI backplane (left-side backplane). DEU connectors J1 (channel 0) and J2 (channel 1) connect to one or two host systems. Switches SW1 through SW8 are used to set termination configurations. Each DEU channel can be independently configured. Refer to Table 3-1 for information on DEU termination configurations. If your DEU includes the Fibre Channel RAID Controller, refer to Table 3-2 for information on DEU termination configurations.

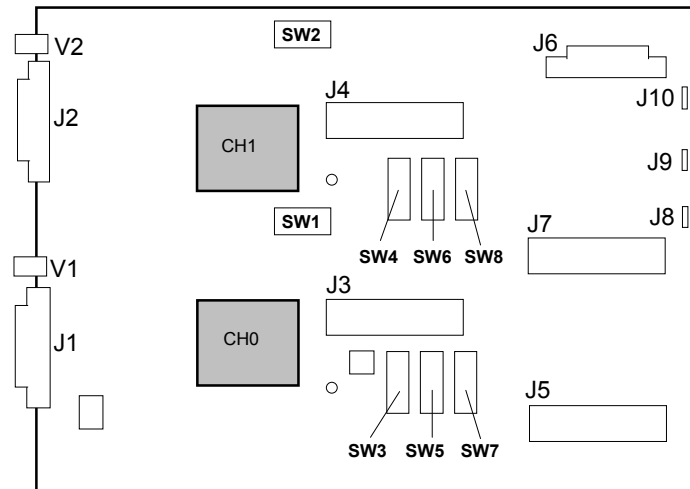

Figure 3-1. DEU Board Switches and Jumpers

Table 3-1. DEU Board Switch Configurations (JBOD)

Function	Channel 0 Switches*	Channel 1 Switches*
Termination Power – Selects the source of SCSI termination power (host or DEU).	SW1: 1-2: Internal (DEU) 2-3: External (Host)	SW2: 1-2: Internal (DEU) 2-3: External (Host)
Automatic External Termination – When enabled, external SCSI interface is automatically terminated at the DEU when required (only one host is connected to the DEU channel).	SW3: 1-2: Enable 2-3: Disable	SW4: 1-2: Enable 2-3: Disable
Manual External Termination - Manually enables or disables the DEU external SCSI interface termination (termination between the DEU and the Host). No effect if Automatic External Termination is enabled.	SW5: 1-2: Disable 2-3: Enable	SW6: 1-2: Disable 2-3: Enable
Manual Internal Termination - Manually enables or disables the DEU internal SCSI termination (termination between the DEU and the SCSI backplane).	SW7: 1-2: Disable 2-3: Enable	SW8: 1-2: Disable 2-3: Enable

* Each channel can be independently configured; default settings are shown in **BOLD**.

Table 3-2. DEU Board Switch Configurations (FC-AL)

Function	Channel 0 Switches*	Channel 1 Switches*
Termination Power – Selects the source of SCSI termination power (host or DEU).	SW1:	SW2:
	1-2: Internal (DEU)	1-2: Internal (DEU)
	2-3: External (Host)	2-3: External (Host)
Automatic External Termination – When enabled, external SCSI interface is automatically terminated at the DEU when required (only one host is connected to the DEU channel).	SW3:	SW4:
	1-2: Enable	1-2: Enable
	2-3: Disable	2-3: Disable
Manual External Termination - Manually enables or disables the DEU external SCSI interface termination (termination between the DEU and the Host). No effect if Automatic External Termination is enabled.	SW5:	SW6:
	1-2: Disable	1-2: Disable
	2-3: Enable	2-3: Enable
Manual Internal Termination - Manually enables or disables the DEU internal SCSI termination (termination between the DEU and the SCSI backplane).	SW7:	SW8:
	1-2: Disable	1-2: Disable
	2-3: Enable	2-3: Enable

* Each channel can be independently configured; default settings are shown in **BOLD**.

Changing the Power Control Mode

The DEU in servers that do not include the Fibre Channel RAID controller (JBOD configurations), has two power control modes: Termination Power Detect (Termination Power) and Local Power Control. In the Termination Power Detect mode (factory default), power to the DEU is controlled by a termination power signal in an external SCSI cable from a host or another DEU. Upon detection of termination power signal, power is automatically switched on to the DEU. In the Termination Power Detect mode, the front panel ON/OFF switch is not used. JBOD DEU models are factory set to operate in the termination power detect mode.

In the Local Power Control mode, the front panel ON/OFF switch controls power to the DEU. Servers that include the Fibre Channel RAID Controller (FC-AL configurations) are always configured in the Local Power Control Mode.

To change the DEU to local power control mode, perform the following steps.

1. Power off the DEU and ensure it is disconnected from the ac wall outlet.
2. Remove the left side panel as described in Chapter 4.
3. Locate Power Control Mode Jumper J9 on the DEU board and move the jumper block from 1-2 to 2-3. See Figure 3-2.

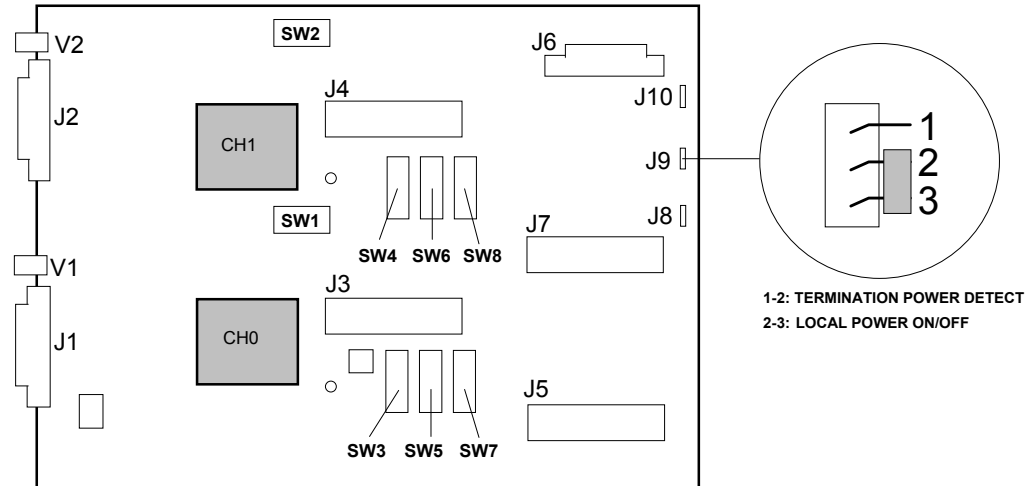

Figure 3-2. Power Control Mode Jumper

4. Install the left side panel.

DEU Cabling (JBOD)

Figure 3-3 illustrates major cable connections within the DEU cabinet. Circled letters next to specific cables reference cables listed in Table 3-3.

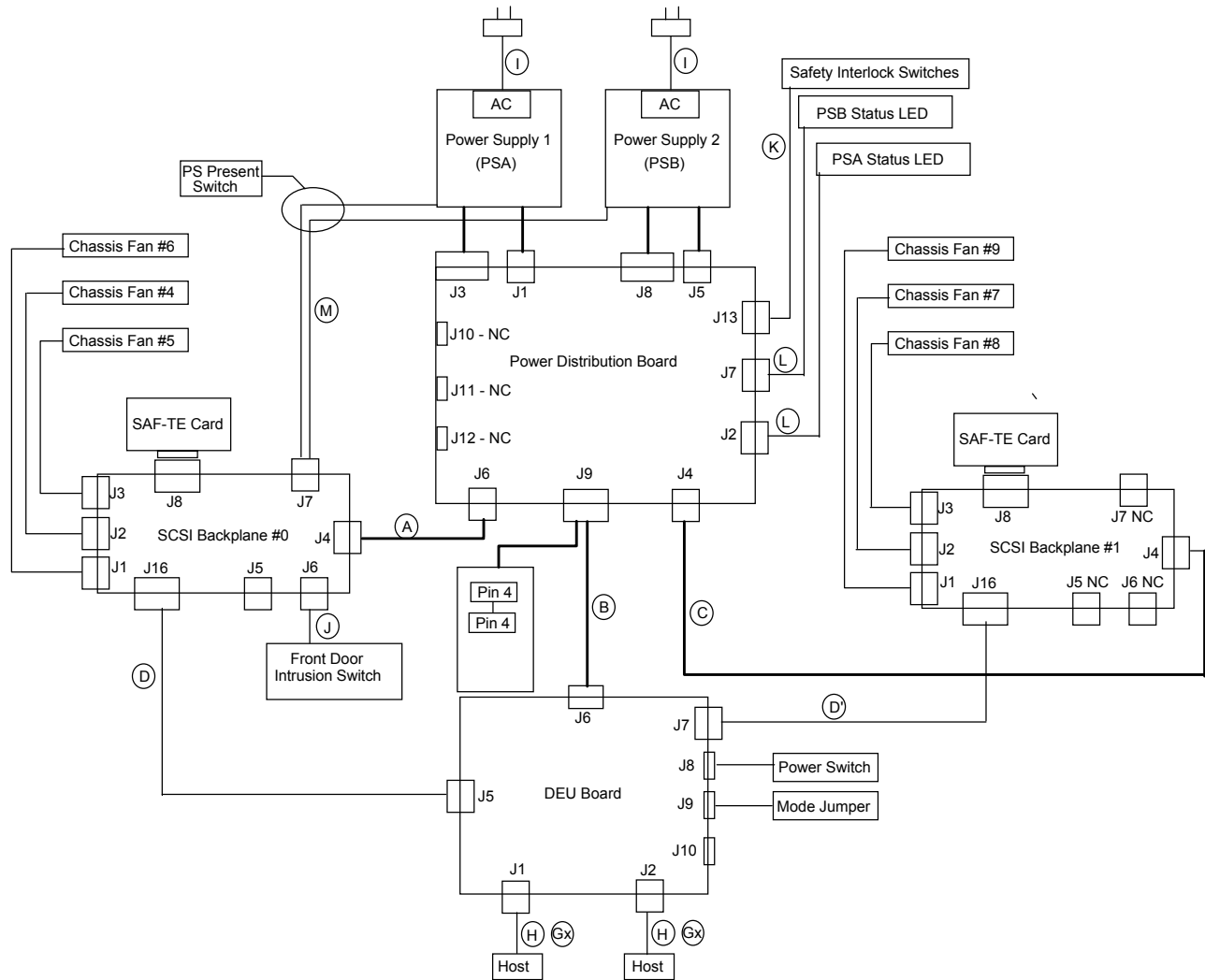

Figure 3-3. DEU Cabling (JBOD)

DEU Cabling (FC-AL)

Figure 3-4 illustrates major cable connections within a DEU cabinet that includes the Fibre Channel Arbitrated Loop (FC-AL) RAID Controller. In this illustration the Fibre Channel RAID Controller is shown in two possible configurations. The first configuration shows the RAID controller cabled in a DEU designated as the Master DEU, while the RAID controller shown in dotted square shows cabling in a DEU designated as a slave DEU. DEUs that include the Fibre Channel RAID Controller are cabled at the factory as either a Master DEU or a slave DEU. Circled letters next to specific cables reference cables listed in Table 3-3.

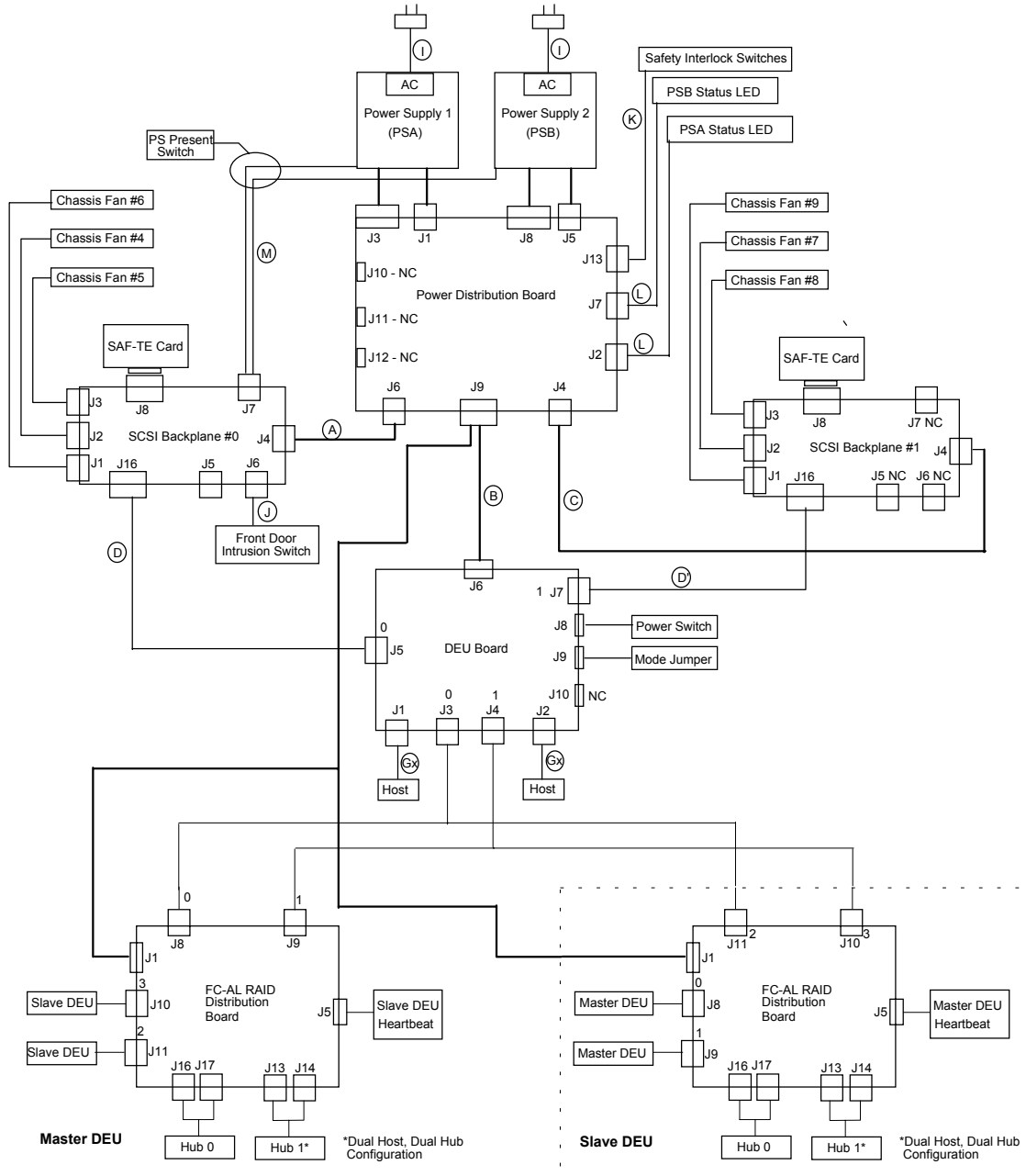

Figure 3-4. DEU Cabling (FC-AL)

Table 3-3. DEU Cables

Cable	Part Number	Type	From	To	To	Length
A	*070982	SCSI-BP1 Power	J6-Power BP (14p)	J4-SCSI-BP1 (14p)	-	316mm
B	*070983	System Power	J9-Power BP (24p)	J6-DEU Brd (20p)	-	365mm
C	*070982	SCSI-BP2 Power	J4-Power BP (14p)	J4-SCSI-BP2 (14p)	-	316mm
D	*320-00005	LVD-LVD Internal	J16-SCSI-BP1 (68p)	J5-DEU Brd (68p)	-	666mm
D'	*320-00005	LVD-LVD Internal	J16-SCSI-BP2 (68p)	J7-DEU Brd (68p)	-	666mm
G1	*320-01515	SCSI External	HD68M	VHDCI	-	3m
G2	*320-01516	SCSI External	HD68M	VHDCI	-	1m
G3	*320-01517	SCSI External	VHDCI	VHDCI	-	3m
G4	*320-01518	SCSI External	VHDCI	VHDCI	-	1m
I	*070146-	AC Line (18ga)	Power Supply	Line	-	6'
J	247-00020	Front Chassis Intrusion	SCSI-BP1 (J6-2p)	Chassis	-	N/A
K	247-00019	Safety Interlock	Power BP (J13-4p)	Chassis	-	N/A
L	247-00015	Power LED	Power BP (J2/J7-4p)	Chassis LED	Chassis LED	N/A
M	247-00015	Power Present SW	SCSI-BP1 (J7-4p)	PS Cage #1	PS Cage #2	N/A

* Field Replaceable Unit (FRU). Refer to the FRU list in Chapter 6 for part number tabs.

4

Upgrading Your DEU

- General Information
- Static Precautions
- Preparing Your DEU for Upgrade
- Opening the Front Door
- Hard Disk Drives
- Removing the Power Supply

General Information

WARNING

Before doing the procedures in this manual, make sure that your DEU is powered off and unplug the AC power cords from the back of the chassis. Failure to disconnect power before opening your DEU can result in personal injury and equipment damage.

CAUTION

Operating your DEU with the side panels removed can damage your DEU components. For proper cooling and airflow, always replace the side panels before powering on your DEU.

Static Precautions

An electrostatic discharge (ESD) can damage disk drives, the DEU board, and other components. You can provide ESD protection by wearing an antistatic wrist strap attached to chassis ground when handling DEU components.

Electronic devices can be easily damaged by static electricity. To prevent damage, keep them in their protective packaging when they are not installed in your DEU.

Preparing Your DEU for Upgrade

Depending on the upgrade, you may need one or more of the following tools:

- Phillips screwdriver (#1 bit and #2 bit)
- Flat-head screwdriver
- Small needle nose pliers
- Pen or pencil
- ESD workstation or antistatic wrist strap (recommended)

Opening the Front Door

Open the front door of the cabinet as follows (tower-based DEU only).

1. If door is locked, unlock the front door.
2. Pull the bottom of the front door out and tilt up until it is aligned level with the top of the cabinet, then push the door back directly over the top of the cabinet as far as it will go. See Figure 4-1.

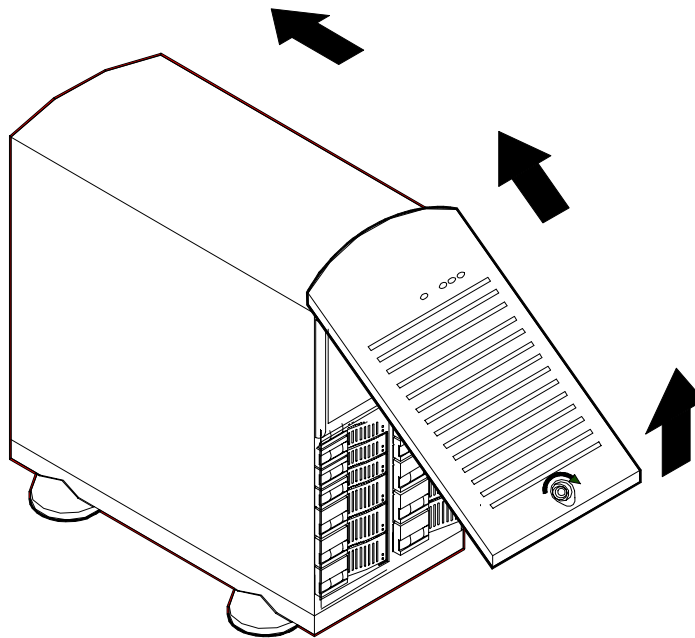

Figure 4-1. Opening the Front Door

Hard Disk Drives

Your DEU supports a variety of SCSI hard disk drives. The SCSI drives must use the industry standard 80-pin Single Connector Attachment (SCA) connector. Contact your sales representative or dealer for a list of approved devices. The internal hard disk drives are located in the SCSI disk drive bays.

If you are adding or removing a SCSI hard disk device, consider the following:

CAUTION

Do not hot swap a non-LVD-disk-drive into an LVD-disk-drive only DEU for it may cause data corruption. The only way a non-LVD-disk-drive can be used with an all LVD-disk-drive DEU is by first powering down the DEU, installing the non-LVD-disk-drive, and then powering the DEU back up.

 **Note:** Installing a non-LVD-disk-drive into an all LVD-disk-drive DEU causes all the drives to operate in the non-LVD mode, thereby reducing performance.

SCSI ID Assignment

Your DEU contains two hard disk drive cages, each with one SAF-TE board and holding a maximum of seven hard disk drives. SCSI ID addresses for the SAF-TE board and drives in the same bay position in either drive cage are identical. For example, the disk drive located in Bay 2 of the left drive cage has a SCSI ID address of 1 as does the disk drive located in Bay 2 of the right drive cage. The hard disk SCSI address assignments for drives in each drive cage are shown in the following table.

Bay	Device	SCSI ID Address
1	First 1.6 inch Hard Disk (Bottom)	0
2	Second 1.6 inch Hard Disk	1
3	Third 1.6 inch Hard Disk	2
4	Fourth 1.0 inch Hard Disk	3
5	Fifth 1.0 inch Hard Disk	4
6	Sixth 1.0 inch Hard Disk	5
7	Seventh 1.0 inch Hard Disk (Top)	15
-	SAF-TE Board	14

Installing or Swapping a Hard Disk Drive in a Hot-swap Bay

This procedure describes installing a new drive or swapping out a faulty drive from one of the fourteen hot-swap SCSI disk drive bays. The SCSI drives use the industry standard 80-pin Single Connector Attachment (SCA) connector. Each drive must be installed in a drive carrier.

 **Note:** To order a disk with a carrier, contact your sales representative or dealer.

- If installing new drives, follow an installation scheme starting with the bottom drive. Fill the bays bottom to top.
- If an individual SCSI drive fault LED (amber light) is on steadily, this indicates that the drive has been flagged as faulty by the RAID host controller. Follow the procedure described in this section to remove the faulty drive and swap in a good one.

 **Note:** ESD can damage disk drives, boards, and other parts. This DEU can withstand normal levels of environmental ESD while you are hot-swapping SCSI hard drives. However, we recommend that you do all procedures in this chapter only at an ESD workstation or provide some ESD protection by wearing an antistatic wrist strap attached to chassis ground—any unpainted metal surface—on your DEU when handling parts.



CAUTION

Drive manufacturers caution against moving a disk drive that is still spinning because of possible damage to the drive.

After you determine which drive has been flagged as faulty, the procedure is the same to swap a drive or to install one for the first time.

Installing or Swapping a Hard Disk Drive

1. Open the front door as described earlier in this chapter.
2. If installing a hard disk drive in a disk carrier for the first time, perform the following procedures:
 - Pull the handle out of the disk bay cover and remove the cover from the SCSI hard disk drive bay. See Figure 4-2.

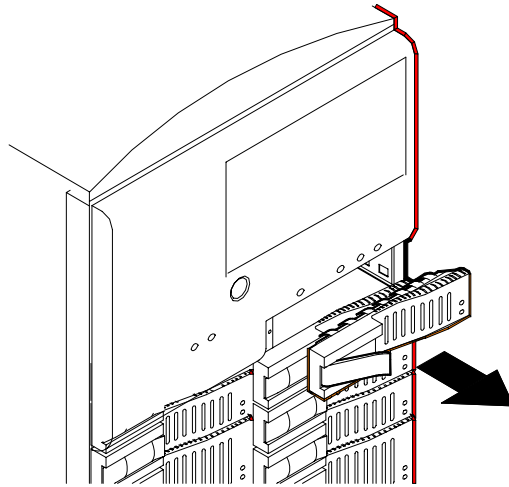

Figure 4-2. Removing the Disk Carrier's Front Panel

- If installing a new drive, go to step 5.
3. If swapping a hard disk drive, remove its carrier from the SCSI hard disk drive bay and perform the following procedures:

CAUTION

Depending on the drive fault, the drive may be still spinning when you remove it. Follow the next steps exactly when removing drives.

- Pull the disk carrier handle out.
 - Pull the faulty disk drive out of the bay far enough to disengage the drive connector from the backplane. Wait 30 seconds until the drive spins down.
 - Remove the carrier from of the drive bay.
4. Remove the hard disk drive from the disk carrier by removing the four screws. See Figure 4-3.
 5. Remove the new drive from its protective wrapper, and place on an antistatic surface.



CAUTION

Observe static precautions. Use an antistatic wrist strap.

6. Record the drive model and serial numbers in the equipment log.
7. Install the drive on the drive carrier (Figure 4-3).
 - Place the drive on the carrier, with its connector facing the back of the carrier.
 - Turn the drive and carrier over and secure the drive in the carrier with the four screws supplied with the disk drive.

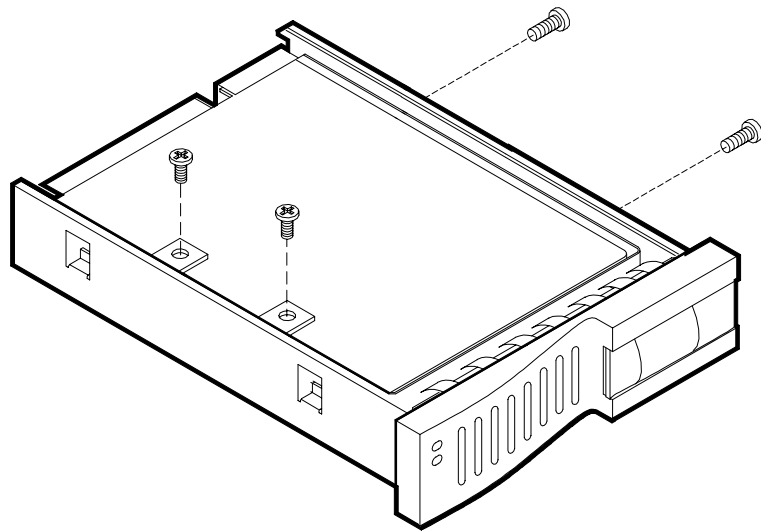

Figure 4-3. Securing the Drive in the Carrier

8. Install the drive carrier with drive into the bay (Figure 4-4) as follows:
 - Open the drive carrier handle.
 - Align the drive carrier with the bay guide rails.
 - Slide the drive carrier into the bay until it docks with the SCSI backplane connector.
 - Push on the carrier until the drive is completely seated into the SCSI backplane connector, and the carrier handle is flush with the front of the carrier.

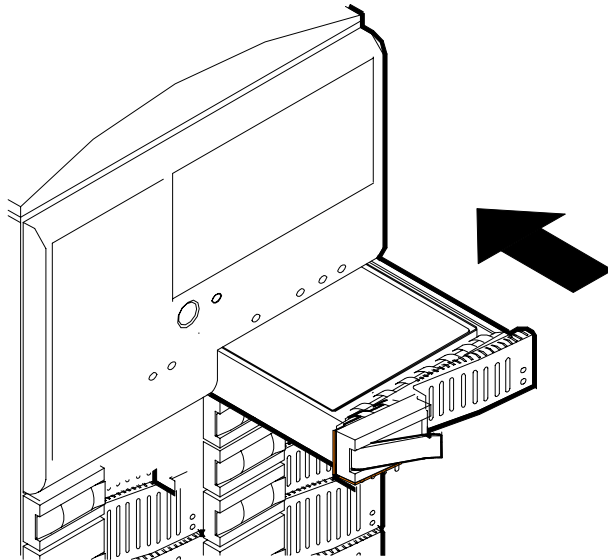

Figure 4-4. Installing a Disk Carrier into the Bay

9. Close the front door on the system.

Removing the Power Supply

1. Power off the system and unplug the power supply ac power cables.
2. Unloosen the three thumbscrews (see Figure 4-5) that secure the power supply assembly to the rear panel.
3. Remove the power supply assembly (B) from the rear of the chassis.

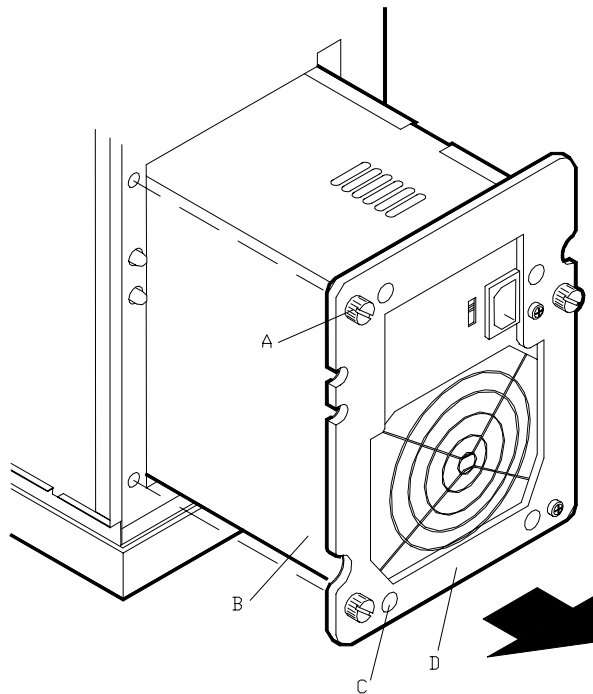

Figure 4-5. Removing the Power Supply

5

Problem Solving

- Introduction
- Static Precautions
- Troubleshooting Tables

Introduction

This chapter provides information to help you identify and solve problems that may occur during DEU installation or while using your DEU.

CAUTION

Operating your system with the side panels removed can damage your system components. For proper cooling and airflow, always replace the side panels before powering on your system.

Static Precautions

An electrostatic discharge (ESD) can damage disk drives, option boards, and other components. You can provide some ESD protection by wearing an antistatic wrist strap attached to chassis ground when handling system components.

Electronic devices can be easily damaged by static electricity. To prevent damage, keep them in their protective packaging when they are not installed in your system.

Initial DEU Startup

Incorrect installation or configuration usually causes problems that occur at initial system startup. Hardware failure is a less frequent cause. If you have problems during initial system startup, check the following:

- Are the system power cords properly connected to the system and plugged into a NEMA 5-15R outlet (100-120 Vac) or a NEMA 6-15R outlet (200-240 Vac)?
- Is AC power available at the wall outlet?
- Is the power on/off push-button switch on the front panel in the ON position (power on LED should be lit)?
- Are all cables correctly connected and secured?
- Are all switch settings on the DEU board correct? For switch information, see Chapter 2, Setting Up Your DEU.
- Are the DEU hard disk drives properly formatted or defined?

If the above items are all correct, but the problem persists, refer to the troubleshooting tables.

Troubleshooting Tables

Symptom	Reason	Solution
DEU fails to power on.	Power cords not connected properly.	Verify that the power cords are properly connected to the power supplies.
	Power not available at the outlet.	If the DEU is plugged into a three-hole grounded outlet, verify if power to the outlet has been interrupted. This can be accomplished by testing the outlet with a known working appliance, like a lamp.
	Power switch not in the proper position.	Be sure that the power switch is in the "ON" position.
	Faulty power cord.	Replace power cord.
	Power Control Mode jumper incorrectly set.	Follow Power Control Mode Setup Procedure in Chapter 3 and check Power Control Mode jumper setting.
		If the DEU does not power after the above checks were made, contact your service provider.
	SCSI cables not attached to host controller.	Attach SCSI cables to the host controller and then power-up the host.
DEU powers on when the external cable is connected.	Power Control Mode set for Termination Power.	Normal operation if the cable is connected to a system that is already powered up.
DEU will not power off from front panel power switch.	Power Control Mode set for Termination Power.	Normal operation; DEU power is controlled by the system power via the external SCSI cables.

Glossary

A

Active/Active

A DEU configuration consisting of two DEU systems, each containing a RAID controller to manage the DEUs. The RAID controllers are coupled together for fault tolerance. If one controller fails the other controller instantly and invisibly (to the Operating System) assumes the duties of the failed controller. Each RAID controller is able to process SCSI commands to its assigned RAID device, nearly doubling the effective transfer rates of a controller. Active/active is also referred to as Dual\Active.

Asynchronous Operations

Operations that bear no relationship to each other in time but can overlap. The concept of asynchronous I/O operations is central to independent access arrays in throughput-intensive applications.

C

Cache Flush

Refers to an operation where all un-written blocks in a Write-Back Cache are written to the target disk. This operation is necessary before powering down the system.

Channel

Refers to one of the SCSI bus connectors on the controllers or termination interface cards.

Cluster

A group of independent computer systems working together as a single system, using a shared disk storage such as a disk expansion unit (DEU). In a two-node cluster, both servers are "active," i.e. servicing client requests just like two network servers. If one of the servers fail, the surviving server initiates a "failover" and the applications running on the failed server can be moved to the surviving server, transparently to clients.

Consistency Check

Refers to a process where the integrity of redundant data is verified. For example, a consistency check of a mirrored drive will make sure that the data on both drives of the mirrored pair are exactly the same. For RAID level 3 and 5 redundancy, a consistency check will involve reading all associated data blocks, computing parity, reading parity, and verifying that the computed parity matches the read parity.

D

Disconnect/Reconnect

Disconnect is a function that allows a target SCSI device (typically a disk drive that received a request to perform a relatively long I/O operation) to release the SCSI bus so that the controller can send commands to other devices. When the operation is complete and the SCSI bus is needed by the disconnected target again, it is reconnected.

Disk Mirroring

Data written to one disk drive is simultaneously written to another disk drive. If one disk fails, the other disk can be used to run the system and reconstruct the failed disk.

Disk Spanning

Several disks appear as one large disk using this technology. This virtual disk can then store data across disks with ease without the user being concerned about which disk contains what data. The subsystem handles this for the user.

Disk Striping

Data is written across disks rather than on the same drive. Segment 1 is written to drive 0, segment 2 is written to drive 1, and so forth until a segment has been written to the last drive in the chain. The next logical segment is then written to drive 0, then to drive 1, and so forth until the write operation is complete.

Duplexing

This refers to the use of two controllers to drive a disk subsystem. Should one of the controllers fail, the other is still available to provide disk I/O. In addition, depending how the controller software is written, both controllers may work together to read and write data simultaneously to different drives.

F

Fault-Tolerant

When something is fault-tolerant it is resistant to failure. A RAID 1 mirrored subsystem, for example, is fault-tolerant because it can still provide disk I/O if one of the disk drives in a mirrored system fails.

FC-AL (Fibre Channel Arbitrated Loop)

A high performance interface in which users can build high capacity, highly available storage networks. FC-AL was developed to improve SCSI performance, connectivity, cabling, storage capacity, and reliability.

H

Hot Spare

The “Hot Spare” is one of the most important features the controller provides to achieve automatic, non-stop service with a high degree of fault tolerance. This rebuild operation will be carried out by the controller automatically when a SCSI disk drive fails.

L

Logical Drive

A set of contiguous chunks of a physical disk. Logical disks are used in array implementations as constituents of logical volumes or partitions. Logical disks are normally transparent to the host environment, except when the array containing them is being configured.

M

Mapping

The conversion between multiple data addressing schemes, especially conversions between member disk block addresses of the virtual disks presented to the operating environment by the array management software.

Mirroring

Refers to the 100% duplication of data on one disk drive to another disk drive. Each disk will be the mirror image of the other.

P

Partition

An array virtual disk made up of logical disks rather than physical ones. Also called logical volume.

Physical Drive

A physical array (or drive) is a collection of physical disks governed by the RAID management software. A physical drive appears to the host computer as one or more logical drives.

R

RAID

(Redundant Array of Independent Disks) An approach to using multiple low cost drives as a group to improve performance, yet also provide a degree of redundancy that makes data loss remote.

RAID 0

Block “striping” is provided, yielding higher performance than is possible with individual drives. This level does not provide any redundancy.

RAID 1

Drives are paired and mirrored. All data is 100% duplicated on an equivalent drive.

RAID 10

RAID 10 is a combination of RAID levels 0 and 1. The data is striped across disks as in RAID 0. Each disk has a mirror disk, as in RAID 1.

RAID 3

Data is striped across several physical drives. For data redundancy one drive is encoded with rotated XOR redundancy.

RAID 30

Data striping of two or more RAID 3 arrays. RAID level 30 is a combination of 0 and 3.

RAID 5

Data is striped across several physical drives. For data redundancy drives are encoded with rotated XOR redundancy.

RAID 50

RAID level 50 is a combination of RAID level 0 and 5.

RAID Controller

This refers to the controller card that routes data to and/ or from the CPU. Disk array controllers perform all RAID algorithms onboard the controller.

Rebuild

The regeneration of all data from a failed disk in a RAID level 1, 3, 5, or 6 array to a replacement disk. A disk rebuild normally occurs without interruption of application access to data stored on the array virtual disk.

Rotated XOR Redundancy

This term (also known as “parity”) refers to a method of providing complete data redundancy while requiring only a fraction of the storage capacity for redundancy. In a system configured under RAID 3 and 5, all data and parity blocks are divided between the drives in such a way that if any single drive is removed (or fails), the data on it can be reconstructed using the data on the remaining drives. (XOR refers to the Boolean “Exclusive-OR” operator.)

S**SAF-TE**

Is the acronym for SCSI Accessed Fault-Tolerant Enclosures. It is a monitoring and communication specification developed by Conner (*nStor*) and Intel for sending and receiving server and storage system status information via the SCSI bus.

Session

Refers to the period of time between any two consecutive system shutdowns. System shutdown may be either a power off/on, or a hardware reset.

SCSI Drive

A disk drive equipped with a small computer system interface (SCSI). Each disk drive will be assigned a SCSI address (or SCSI ID), which is a number from 0 to 15. The SCSI address uniquely identifies the drive on the SCSI bus or channel.

Spanning

Disk spanning allows multiple disk drives to function like one big drive. Spanning overcomes lack of disk space and simplifies storage management by combining existing resources or adding relatively inexpensive resources.

Striping

Disk striping writes data across multiple disks rather than on one disk. disk striping involves partitioning each drive storage space into stripes that can vary in size from one sector (1 KB) to several megabytes.

Stripe Order

The order in which SCSI Drives appear within a Physical Pack. This order must be maintained, and is critical to the controller's ability to "Rebuild" failed drives.

Stripe Width

Refers to the number of kilobytes per stripe block.

T**Target ID**

A target ID is the SCSI ID of a device attached to the disk array controller. Each SCSI channel can have up to sixteen SCSI devices (target ID from 0 to 15) attached to it.

W**Write-Through Cache**

Refers to a cache writing strategy whereby data is written to the SCSI Drive before a completion status is returned to the host operating system. This caching strategy is considered more "secure," since a power failure will be less likely to cause loss of data. However, a Write-Through cache results in a slightly lower performance, in most environments.

Index

C

- Cables, 2-8
- Cabling Configurations, 2-8
- Cabling Connections, 2-8
- Changing the Power Control Mode, 2-18
- Configuring and Upgrading, 3-1, 4-1
- Connecting the Power Cord(s), 2-17

D

- DEU Board Features, 1-15
- DEU Controls and Indicators, 1-4
- DEU Security, 1-8
- DEU Startup, 5-2
- DEU Status Indicator LEDs, 1-5
- Disk Drive Status Conditions, 1-5, 1-6, 1-18
- Disk Drive Status Indicator LEDs, 1-6, 1-11, 1-17, 1-18

F

- Fast SCSI, 2-8
- Fast Wide SCSI, 2-8

G

- Glossary, 1

H

- Hard Disk Drives
 - Installing or Swapping, 4-5
 - SCSI ID Assignment, 4-4
- Hot Swappable Power Supplies, 1-7
- Hot Swappable SCSI Disk Drive Bays, 1-4

I

- I/O Panel Connectors, 1-7
- I/O Panel Disk Transfer Mode LEDs, 1-7
- Intrusion detection, 1-8

L

- Line Voltage, 2-15
- local power control, 2-18

O

- Overview, 1-2

P

- Power Control Mode
 - configuring, 3-5
- Power Supply
 - removing, 4-8

- Power Supply Status Indicator LEDs, 1-5, 1-16, 1-17, 1-18
- Power Switch, 1-5, 1-6, 1-15
- Problem Solving, 5-1

R

- Rack-Mount Subsystem Assembly, 2-4
- Redundant Cooling Fans, 1-7
- Remote/Delay Start, 1-3

S

- SAF-TE Board, 1-4
- SCSI bus termination power, 2-18
- Security
 - alarm switches, 1-8
- Selecting a Site, 2-2
- Server management
 - intrusion detection, 1-8
- Setting Up Your DEU, 2-1
- Status Indicator LED Descriptions, 1-17
- Switches
 - alarm, 1-8
- System Chassis, 1-13

T

- Termination, 2-8
- Troubleshooting, 5-2
- Troubleshooting Tables, 5-3

U

- Ultra SCSI
 - Fast 20, 2-8
- Unpacking the DEU, 2-3

- Error! Cannot open file referenced on page 4**

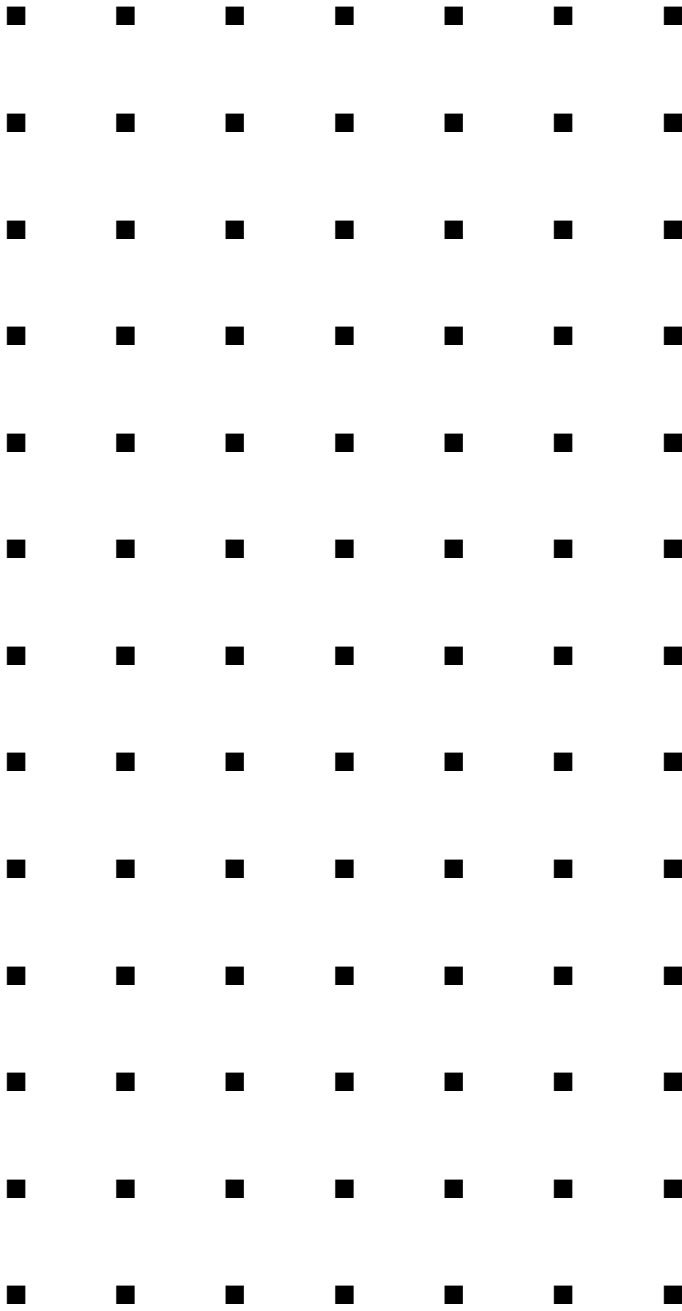

456-01508-001